

**DRAFT**  
**GEOTECHNICAL BASIS OF DESIGN**  
**CARLSBAD BEACH ACCESS REPAIRS**  
**CARLSBAD, CALIFORNIA**

*REFERENCE: CIP PROJECT 3896*

Prepared for  
**GHD**  
Irvine, California

Prepared by  
**TERRACOSTA CONSULTING GROUP, INC.**  
San Diego, California

Project No. 3009  
July 3, 2018



# Addendum

*This document contains information and data from a study that was prepared for a prior version of the proposed Project. The data contained within remains relevant and applicable to the proposed Project; however, may contain information that is no longer representative of the proposed Project. Please reference the Initial Study Mitigated Negative Declaration document for any information pertinent to the proposed Project description.*



Geotechnical Engineering  
Coastal Engineering  
Maritime Engineering

Project No. 3009  
July 3, 2018

Mr. Robert Sherwood  
**GHD**  
175 Technology Drive, Suite 200  
Irvine, California 92618

**DRAFT**  
**CARLSBAD BEACH ACCESS REPAIRS**  
CARLSBAD, CALIFORNIA

***REFERENCE: CIP PROJECT 3896***

Dear Mr. Sherwood:

In accordance with your authorization of our revised proposal dated February 8, 2018, TerraCosta Consulting Group, Inc. is pleased to present this Geotechnical Basis of Design report for the City of Carlsbad Beach Access Repairs project. The project consists of the rehabilitation of the existing public access improvements located along the west side of Carlsbad Boulevard from Pine Avenue to Tamarack Avenue in the City of Carlsbad, California.

This report provides a summary of our review of existing geologic information, a summary of our geotechnical observations during field mapping, our findings regarding the geologic conditions at the site, and our preliminary geotechnical recommendations for the design and repair of the project components.

We appreciate the opportunity to work with you on this project and trust this information meets your current needs. If you have any questions or require additional information, please give us a call.

Very truly yours,

TERRACOSTA CONSULTING GROUP, INC.

Greg Walt

/jg  
Attachments

## TABLE OF CONTENTS

<b>1</b>	<b>INTRODUCTION.....</b>	<b>1</b>
1.1	Site Description .....	1
<b>2</b>	<b>SCOPE OF SERVICES .....</b>	<b>3</b>
<b>3</b>	<b>REVIEW OF GEOLOGIC MAPS .....</b>	<b>3</b>
3.1	Regional Geologic Map.....	4
3.2	Fault Activity Map.....	4
3.3	Earthquake Fault Zone Map .....	4
3.4	Tsunami Inundation Map.....	4
3.5	Landslide Hazard Identification Map .....	4
<b>4</b>	<b>REVIEW OF PREVIOUS GEOTECHNICAL REPORTS .....</b>	<b>5</b>
<b>5</b>	<b>SUMMARY OF GEOTECHNICAL CONDITIONS .....</b>	<b>5</b>
5.1	Geologic Setting .....	5
5.2	Soil/Geologic Units .....	6
5.3	Geologic Structure.....	7
5.4	Groundwater .....	7
<b>6</b>	<b>GEOLOGIC HAZARDS EVALUATION .....</b>	<b>7</b>
6.1	Faulting and Seismicity .....	7
6.2	Ground Surface Rupture .....	8
6.3	Liquefaction.....	8
6.4	Tsunami .....	8
6.5	Landslides .....	8
6.6	Possibility of Soil Contamination.....	8
<b>7</b>	<b>GEOTECHNICAL OBSERVATIONS AND CONCLUSIONS .....</b>	<b>8</b>
7.1	Access Stairway No. 1 .....	9
7.2	Access Stairway No. 2.....	9
7.3	Access Stairway No. 3.....	10
7.4	Access Stairway No. 4.....	11
7.5	Access Stairway No. 5 and Southern Restroom Facility.....	12
7.6	Access Stairway No. 6 and Retaining Wall.....	13
7.7	Bluff-Top Sidewalk – Precast Sections .....	13
7.8	Bluff-Top Sidewalk – Slab-on-Grade Sections .....	13
7.9	Bluff-Toe Sidewalk, Curb, and Retaining Wall .....	13
7.10	Carlsbad Seawall .....	14
<b>8</b>	<b>ENHANCEMENT OF SURFICIAL BLUFF STABILITY.....</b>	<b>14</b>
8.1	Surface Water and Groundwater Control .....	15
8.2	Vegetation and Irrigation System Maintenance .....	15
8.3	Rodent Control.....	15
8.4	Installation of Retaining Structures .....	16



**TABLE OF CONTENTS**  
(continued)

<b>9</b>	<b>PRELIMINARY FOUNDATION/SLAB RECOMMENDATIONS .....</b>	<b>16</b>
9.1	Foundation Design for Sidewalk Support/Retaining Walls.....	16
9.2	Slab Design for On-Grade Sidewalk Slabs.....	17
9.3	Retaining Walls .....	18
9.4	Structural Fill Placement .....	18
<b>10</b>	<b>ADDITIONAL GEOTECHNICAL STUDIES.....</b>	<b>19</b>
<b>11</b>	<b>LIMITATIONS .....</b>	<b>19</b>

REFERENCES

FIGURE 1	VICINITY MAP
FIGURES 2 – 9	PROJECT MAPS WITH PHOTOS
FIGURE 10	REGIONAL GEOLOGIC MAP AND LEGEND
FIGURE 11	REGIONAL FAULT MAP
FIGURE 12	TSUNAMI INUNDATION MAP
FIGURE 13	LANDSLIDE DISTRIBUTION MAP

APPENDIX A	PHOTOGRAPHS
APPENDIX B	PREVIOUS GEOTECHNICAL REPORTS



**DRAFT**  
**GEOTECHNICAL BASIS OF DESIGN**  
**CARLSBAD BEACH ACCESS REPAIRS**  
**CARLSBAD, CALIFORNIA**

## 1 INTRODUCTION

This Geotechnical Basis of Design report has been prepared for the City of Carlsbad Beach Access Repairs project. This report summarizes of our review of existing geologic maps and information, and provides a summary of geotechnical observations during our field mapping of the project site. In addition, this report presents our findings regarding the geologic conditions at the project site and our preliminary geotechnical recommendations for the design and repair of the project components. Geotechnical information from previous geotechnical studies for the existing public access improvements was also reviewed to assist in preparation of this report. **Final recommendations will be provided after repair alternatives have been selected.**

### 1.1 Site Description

The City of Carlsbad Beach Access Repairs project consists of the rehabilitation of the existing public access improvements located along the west side of Carlsbad Boulevard from Pine Avenue to Tamarack Avenue in the City of Carlsbad, California (Figure 1).

The project is described in the City of Carlsbad's RFP dated June 28, 2017, as extending from Pine Avenue to Tamarack Avenue for a length of approximately 3,200 feet. The project site includes a westerly facing coastal bluff. The project plans provided by GHD show the subject coastal bluff extending from approximately 400 feet north of Pine Avenue to approximately 650 feet south of Tamarack Avenue, for a total distance of approximately 4,300 feet (Figures 2 through 9). In general, the existing westerly facing bluff is approximately 30 feet in height with an overall gradient varying from about 1.5:1 to 2.5:1 (horizontal to vertical). Localized areas with oversteepened and near-vertical gradients exist on the bluff face. Irrigation lines and sprinkler heads exist on the bluff face. Vegetative cover ranges from no coverage (exposed soil) to dense vegetative growth. Rodents (ground squirrels, rabbits, etc.) and their associated burrows were observed during our site visits. To

illustrate the various aspects of the project site, we have provided photographs on Figures 2 through 9 and in Appendix A.

The primary public access improvements at the site include concrete walkways, beach access stairways, retaining walls, and the “Carlsbad Seawall.” A concrete walkway is located along the west side of Carlsbad Boulevard along the top of the coastal bluff from Pine Avenue to south of Tamarack Avenue. The majority of the bluff-top walkway northerly of about Chestnut Avenue consists of precast concrete panels supported on regularly spaced transverse pier-supported foundation elements. The southern majority of the bluff-top walkway consists of concrete slabs on grade. An asphalt concrete parking lot and adjacent asphalt walkway exist at the top of the bluff at the northern end of the project area (Figure 2).

A concrete slab-on-grade walkway exists along the toe of the coastal bluff (from about 200 feet south of the western terminus of Pine Avenue to about 200 feet south of Tamarack Avenue). The “Carlsbad Seawall” exists along the westerly side of this bluff-toe walkway. The sand beach of Carlsbad State Beach exists westerly of the seawall. Northerly of Hemlock Avenue, an approximately 3.3-foot-high bluff-toe wall exists along the easterly side of this walkway, and the majority of this wall retains sloughed soils. Southerly of Hemlock Avenue, a low concrete curb defines the easterly edge of the concrete walkway.

Public beach access stairways descend the coastal bluff at the project site. Four of these access stairways are elevated on pier supports and are labeled on the Project Maps as Access Stairway Nos. 1, 2, 3, and 4 (Figures 4, 6, and 7). These four stairways are located at the approximate western termini of Hemlock Avenue, Cherry Avenue, Maple Avenue, and Sycamore Avenue, respectively. Access Stairway No. 4 was fenced off and being repaired at the time of our field visits on May 10 and May 12, 2018.

Two other beach access stairways are shown on the Project Maps. A stairway descends from the restroom near Tamarack Avenue and consists of on-grade concrete stairs (labeled as Access Stairway No. 5 on Figure 8). Another set of on-grade concrete stairs descends from Carlsbad Boulevard approximately 650 feet south of Tamarack Avenue (labeled as Access Stairway No. 6 on Figure 9).

Two restroom facilities exist in the project area. The northern restroom is located at the toe of the bluff between Pine Avenue and Walnut Avenue (Figure 3). This restroom and the beach are accessed by vehicles via an asphalt concrete driveway that obliquely crosses the

bluff face and descends southerly from Carlsbad Boulevard. The southern restroom facility is located near the top of the bluff at the western terminus of Tamarack Avenue (Figure 8). Southeasterly of this restroom, an asphalt driveway obliquely descends the bluff face to a public parking lot at the south end of the project area.

The condition of the concrete walkways, stairways, and walls varies. Some portions of the sidewalks, access stairways, and walls show deterioration such as concrete spalling, cracking, and exposed rebar, likely due to the corrosive nature of the marine environment. In places, soil has been eroded away from foundation elements. The subject project consists of the design for repair of the deteriorating public access improvements.

## **2 SCOPE OF SERVICES**

The purpose of this Geotechnical Basis of Design is to provide preliminary geotechnical recommendations for the design and rehabilitation of the deteriorating public access improvements in the project area. Our services included review of geologic maps and information, review of previous geotechnical reports for the existing improvements, field mapping by a geologist, geotechnical evaluations, and preparation of this report. A list of the reviewed geologic maps/information is provided at the end of this report (see References). Our scope of services did not include subsurface exploration of the on-site soils conditions and geotechnical laboratory testing. In addition, we did not walk on the bluff-face soils.

## **3 REVIEW OF GEOLOGIC MAPS**

As part of our geotechnical studies, geologic maps pertaining to the general area were reviewed. The reviewed maps are listed at the end of this report under References. Please note that the maps reviewed are primarily intended for general information and planning purposes. Although they are not intended for evaluation of individual sites, they can provide general indications of the soils and geologic conditions, and the presence of known geologic hazards.

### 3.1 Regional Geologic Map

Our review of the California Geological Survey's Regional Geologic Map No. 3 indicates that the subject property is underlain by the geologic sedimentary units termed "old paralic deposits, undivided (late to middle Pleistocene)" and "Santiago Formation (middle Eocene)" (Figure 10). The "old paralic deposits" (Unit 6 and Unit 6-7) underlie the majority of the subject coastal bluff and bluff-top area. They are described as generally consisting of sandstone, siltstone, and conglomerate. The lowermost portion of the coastal bluff is mapped as being comprised of Santiago Formation, primarily sandstone dipping 10 degrees northerly.

### 3.2 Fault Activity Map

Our review of the California Geological Survey's Geologic Data Map No. 6 indicates that no mapped faults cross the subject property. A Regional Fault Map is included as Figure 11.

### 3.3 Earthquake Fault Zone Map

Our review of California Geological Survey's Special Publication 42 indicates that the subject coastal bluff is not located within or crossed by a State-delineated Alquist-Priolo Earthquake Fault Zone. Alquist-Priolo Earthquake Fault Zones are typically delineated along active faults. An active fault is defined as one that has "had surface displacement within Holocene time (approximately the last 11,000 years)."

### 3.4 Tsunami Inundation Map

An online "Tsunami Inundation Map for Emergency Planning (Oceanside Quadrangle/San Elijo Quadrangle), San Diego County, California" was prepared jointly by the California Emergency Management Agency, California Geological Survey, and the University of Southern California. The bluff-toe area and beach westerly of the subject coastal bluff are mapped within a tsunami inundation zone (Figure 12).

### 3.5 Landslide Hazard Identification Map

Our review of the California Division of Mines and Geology's Open-File Report 95-04 (Oceanside and San Luis Rey Quadrangles) indicates that the subject property is mapped in

"Relative Landslide Susceptibility" Areas 2 and 4-1 (Figure 13). Our review indicates that no known or "questionable" landslides are mapped at the site.

Area 2 is described as areas that are "marginally susceptible" to "all types of slope hazards." Area 2 "includes gentle to moderate slopes, where slope angles are generally less than 15 degrees... Landslides and other slope failures are rare within this area..."

Area 4-1 is described as areas that are "most susceptible" to "all types of slope hazards." Area 4-1 includes "oversteepened high coastal bluffs which are subject to active sea-wave erosion", such as the coastal bluff at the subject property.

#### **4 REVIEW OF PREVIOUS GEOTECHNICAL REPORTS**

Two geotechnical reports for the design and construction of the "Carlsbad Boulevard Seawall" and "Carlsbad Boulevard Promenade" projects were provided for our review. The relevant geotechnical information in those reports (prepared by Woodward-Clyde Consultants) assisted in our interpretation of the geologic conditions at the subject property. The 1986 report includes the logs of three exploratory borings and geotechnical laboratory test results. Copies of the reviewed reports (listed at the end of this report under References) are provided in Appendix B.

#### **5 SUMMARY OF GEOTECHNICAL CONDITIONS**

The project site, located along the west side of Carlsbad Boulevard from approximately Pine Avenue to Tamarack Avenue (Figure 1), extends along the west side of Carlsbad Boulevard for approximately 4,300 feet and includes a westerly facing coastal bluff. Our interpretation of the general geologic conditions at the site is described below.

##### **5.1 Geologic Setting**

The City of Carlsbad is located in the coastal section of the Peninsular Ranges geomorphic province. The northwesterly trending mountain ranges of this province are generally underlain by basement rocks consisting of Jurassic metamorphic rocks intruded by Cretaceous igneous rocks of the Peninsular Ranges batholith. During the past 54 million

years, the western coastal flank of this mountainous area has experienced several episodes of marine inundation and subsequent regression. This resulted in deposition of a sequence of marine and non-marine sediments (claystones, siltstones, sandstones, and conglomerates) on the basement rocks in this area. During the past 2 million years, terrace deposits associated with various, relatively static sea level stands were deposited and mantle the coastal terrain. More recently, human actions have locally modified the natural topography. Hilltops have been excavated and low-lying areas have been infilled by the removal and placement of various quantities of soils.

## 5.2 Soil/Geologic Units

Based on our field reconnaissance and review of geologic maps and previous reports, the majority of the subject coastal bluff site is underlain by “old paralic deposits,” which are commonly called “terrace deposits.” At the site, these terrace deposits appear to generally consist of poorly indurated to locally well indurated, slightly silty, fine- to medium-grained sandstone. The majority of the terrace deposits at the site are friable and easily eroded. In places, upper portions of the terrace deposits are cemented and eroded into near-vertical slopes with rills. Surface water, groundwater, gravity, rodents and other factors erode these soils and deposit the soils downslope resulting, with time, in a bluff face with a gentler gradient. This slope flattening is a natural process and can be accelerated, or retarded, by various factors.

The previous geotechnical reports and published geologic map of the area (see References) indicate that Santiago Formation underlies the terrace deposits along the majority of the toe of the coastal bluff. The Santiago Formation was not observed during our site visits and is apparently hidden by the existing bluff-toe improvements and vegetative cover. Our review of the boring logs included in the previous geotechnical report indicates that the contact between the terrace deposits and underlying Santiago Formation is at approximate elevation 7 to 15 feet (National Geodetical Vertical Datum). Relatively minor amounts of fill soils exist at the subject property. Deeper fills associated with the backfill of storm drain trenches exist at the western termini of Walnut, Sycamore, and Maple Avenues. The on-site geologic units (excluding fill) are generally known to exhibit adequate bearing characteristics for typical light construction (i.e., walkways and restrooms, as exist at the site). In addition, the on-site soils are generally anticipated to have a very low to low expansion potential, though localized areas of soils with a high expansion potential may exist at the site.

### 5.3 Geologic Structure

The terrace deposits are generally flat-lying to slightly westerly dipping, but they may exhibit localized variability due to scouring, lensing, and cross-stratification. The underlying Santiago Formation is mapped as generally dipping 10 degrees to the north, obliquely into the coastal bluff face. Adverse out-of-slope bedding conditions were not observed during our site visits and are not anticipated at the site.

### 5.4 Groundwater

A perched groundwater condition was reported to exist along the contact of the terrace deposits with the underlying Santiago Formation (References 8 and 9). Heavy vegetative growth indicative of groundwater seeps (and possibly storm drain discharge) was observed on the west side of the seawall during our site visits. Wet soils, possibly from surface infiltration of irrigation waters, were observed near the beach access stairway labeled Access Stairway No. 2 (see Figure 6 and photos in Appendix A). Groundwater may be locally perched in the on-site soil/geologic units and may exist in trench backfill soils. Fluctuations in groundwater elevations are likely to occur as the result of tidal fluctuations, sea level rise, rainfall and irrigation infiltration, and other factors.

## 6 GEOLOGIC HAZARDS EVALUATION

### 6.1 Faulting and Seismicity

Our review of geologic maps and literature indicates that there are no known major or active faults near or projecting toward the subject property. The site is, however, located in a moderately active seismic region of Southern California that is subject to significant hazards from moderate to large earthquakes. Ground shaking could affect the site in the event of an earthquake on any of the active fault zones located in or offshore of Southern California.

The nearest known active faults are within the Newport Inglewood-Rose Canyon fault zone located offshore approximately 2 miles to the west of the site (refer to the Regional Fault Map, Figure 10). The maximum credible earthquake assigned to the Rose Canyon Fault is Magnitude 7; the maximum probable earthquake is Magnitude 6.5. Other active fault zones within about 60 miles of the site, which could generate ground shaking at the site, are the



Coronado Bank, La Nacion, San Diego Trough, San Clemente, Newport-Inglewood, Elsinore, and San Jacinto fault zones. The San Andreas fault zone is located approximately 65 miles to the northeast of the site.

## 6.2 Ground Surface Rupture

The potential for ground surface rupture along a fault at the site is considered nonexistent to very low since no known faults are known to cross the site.

## 6.3 Liquefaction

The potential for liquefaction or seismically induced ground settlement due to an earthquake is considered very low due to the dense nature of the geologic units at the site.

## 6.4 Tsunami

The subject property is located on the coast. The existing bluff-toe improvements are at the eastern edge of the anticipated tsunami inundation area delineated by the State of California (Figure 12).

## 6.5 Landslides

Our site observations and review of geologic literature (Figure 13) provide no indication that areas at or adjacent to the site are underlain by deep-seated landslides. However, indications of relatively shallow surficial slope failures were observed.

## 6.6 Possibility of Soil Contamination

Assessment of soil contamination, if any, is beyond the scope of this study. If any soil contamination exceeds allowable limits, environmental regulations will likely require remediation or disposal in specialized landfills.

## 7 GEOTECHNICAL OBSERVATIONS AND CONCLUSIONS

This Geotechnical Basis of Design report has been prepared for the City of Carlsbad Beach Access Repairs project. This report presents a summary of our review of existing geologic

maps and information. A summary of our observations and comments for each of the site improvements in the project area are presented below

### 7.1 Access Stairway No. 1 (Hemlock Ave)

Access Stairway No. 1 is near the western terminus of Hemlock Avenue (Figure 7). Photos of this stairway are included in Appendix A. The foundation elements include three drilled piers in the bluff face. Based on our review of the 1986 geotechnical report, **the drilled piers were advanced to a depth of 25 feet below the upper sidewalk and are founded in Santiago Formation.**

Portions of the upper bluff face in the area of this stairway include localized, oversteepened rills, apparently eroded by surface waters on the bluff face. These near-vertical areas appear to be underlain by somewhat well-indurated, cemented terrace deposits. Accumulations of eroded and sloughed soils are apparent in the lower portion of the bluff area. Limited amounts of soil appear to have been eroded away from the middle pier support.

A concrete-plugged plastic pipe and adjacent rill were observed on the bluff face southerly of Access Stairway No. 1. The easterly side of the bluff-toe walkway at the base of this stairway is bordered by a concrete wall that retains bluff-toe soils, including accumulations of sloughed soils.

**It is our opinion that no significant erosion mitigation measures and/or modifications to this bluff-face area are currently warranted other than for general control of surface waters and rodent activity.**

### 7.2 Access Stairway No. 2 (Cherry Ave)

Access Stairway No. 2 is near the western terminus of **Cherry Avenue** (Figure 6). Photos of this stairway are included in Appendix A. The foundation elements include two drilled piers in the bluff face. Based on our review of the previous 1986 geotechnical report, **the drilled piers were advanced to a depth of 25 feet below the upper sidewalk and are founded in Santiago Formation.**

**Portions of the bluff face in the area of this stairway include localized, oversteepened rills, apparently eroded by surface waters on the bluff face.** A rill on the north side of the stairway

appears to be the result of an irrigation line break/leak. The soils in this rill are moist to wet. The accumulated soils at the base of this rill are moist to wet. Fill soils with asphalt and concrete debris are apparent at and near this stairway.

The remnants of an old stairway consisting of roughly horizontal railroad ties anchored with vertical rebar pieces were observed in the vicinity of the upper portion of this stairway. A pipe-and-board retaining structure retains soil on the downslope side of the bluff-top landing foundation. Sandbags are reported to also have been placed to stabilize the former stairway (Reference 8). Straw wattles were observed on the slope. **Soils have been eroded away from the foundation elements on the upper portion of this stairway and deposited downslope.** The easterly side of the bluff-toe walkway at the base of this stairway is bordered by a concrete wall that retains bluff-toe soils, including accumulations of sloughed soils.

**It is our opinion that erosion mitigation measures and/or modifications to this bluff-face area may be warranted.** Such measures and/or modifications include inspection and repair of irrigation pipes and sprinklers. **Other measures and/or modifications for consideration include enhanced interception and control of surface water flow and using alternate soil-retaining devices to replace the existing sand bags and wattles and to better stabilize the bluff-face soils.** In addition, care and minimal disturbance of slope soils should be considered when working on the slope. For example, if removal of the old railroad-tie stairway is proposed, the bluff-face soils should not be disturbed as much as practicable. Also, the vertical rebar should not be pulled out of the bluff face, but can be cut off at the slope face.

### 7.3 Access Stairway No. 3 (Maple Ave)

Access Stairway No. 3 is northerly of the western terminus of **Maple Avenue** (Figure 5). Photos of this stairway are included in Appendix A. The foundation elements include three drilled piers in the bluff face. Based on our review of the 1986 geotechnical report, **the drilled piers were advanced to a depth of 25 feet below the upper sidewalk and are founded in Santiago Formation.**

The middle pier appears to be in a bluff-face area that is not experiencing much surficial soil erosion. Portions of the bluff face in the area of the upper pier support include localized, oversteepened rills, apparently eroded by surface waters on the bluff face. These near-

vertical areas appear to be underlain by somewhat well-indurated, cemented terrace deposits. Soils have apparently been eroded from this upper pier support area and were transported downslope. Accumulations of eroded and sloughed soils are apparent in the lower portion of the bluff area and near the lowest bluff-face pier support. Straw wattles have been placed to reduce the accumulation of eroded soils on the lower pier-supported stairway landing. Sandbags were placed to retard soil erosion and are located in the area between the southern side of the stairway and the retaining wall termination at the bluff toe.

It is our opinion that erosion mitigation measures and/or modifications to this bluff-face area may be warranted. Such measures and/or modifications include constructing a series of relatively short retaining wall structures to stabilize the soils in the vicinity of the upper pier support, as well as continued maintenance and regular inspection of irrigation systems, including pipes and sprinklers. The retaining structures are intended to reduce the accumulation of eroded soils on and near the lower stairway landing. In addition, the aesthetics of these soil-retaining structures can be enhanced by facing the walls with a rock-like finish. Lastly, enhanced interception and control of surface water flow should be considered to mitigate the development of new and old erosion features.

#### 7.4 Access Stairway No. 4 (Sycamore Ave)

Access Stairway No. 4 is located between the western termini of Sycamore and Chestnut Avenues (Figure 4). Photos of this stairway are included in Appendix A. This stairway area was fenced at the time of our site visits, as the stairway steps were being removed and the supports being repaired. The foundation elements for this stairway include three drilled piers in the bluff face. Based on our review of the 1986 geotechnical report, the drilled piers were advanced to a depth of 25 feet below the upper sidewalk and are founded in Santiago Formation.

Portions of the bluff face include localized oversteepened rills, apparently eroded by surface waters on the bluff face. These near-vertical areas appear to be underlain by somewhat well-indurated, cemented terrace deposits. Accumulations of eroded and sloughed soils are apparent in the lower portion of the bluff area. A plugged and corroded corrugated metal pipe and adjacent rill were observed on the bluff face, southerly of Access Stairway No. 4.

It is our opinion that no significant erosion mitigation measures and/or modifications to this bluff-face area are currently warranted other than for general control of surface waters and rodent activity.

#### 7.5 Access Stairway No. 5 and Southern Restroom Facility

A concrete stairway and the southerly restroom building are located at the western terminus of Tamarack Avenue in the project area. This stairway is labeled as Access Stairway No. 5 on Figure 8. Photos of this stairway and restroom building are included in Appendix A. This stairway consists of concrete steps on grade that descend from the restroom to the bluff-toe walkway.

A southerly sloping, concrete sidewalk descends from the bluff-top sidewalk to the restroom entrance and top of the stairway. A retaining wall (with varying height) borders the easterly edge of this sloping sidewalk. Retaining walls also comprise the east, south, and north sides of the restroom building. The building entrance and adjacent sidewalk are approximately 8 feet lower than the elevation of Carlsbad Boulevard.

Cracks in the sloping sidewalk were observed and voids under the sidewalk were detected (see Figure 8 and photos in Appendix A). Rodent burrows were observed adjacent to the restroom and hardscape improvements. Soils have been eroded away from the foundations for the restroom (likely by surface water, rodents, and gravity).

It is our opinion that erosion mitigation measures and/or modifications to this bluff-face area may be warranted. Such measures and/or modifications include infilling the underlying voids (which should be filled prior to repairing the cracked sloping sidewalk), stabilizing the soils in the vicinity of the east and south sides of the restrooms, enhanced interception and control of surface water flow to mitigate the development of new and old erosion, continued maintenance and regular inspection of irrigation systems including pipes and sprinkler, and deterrence of rodent activity.

Recommendations for concrete slabs on grade are provided below in Section 9. Various surficial soil-stabilizing product alternatives may be considered to stabilize the soils in the vicinity of the east and south sides of the restroom.

## 7.6 Access Stairway No. 6 and Retaining Wall

A concrete stairway exists at the southeast corner of the asphalt concrete parking lot at the southern end of the project area. This stairway is labeled as Access Stairway No. 6 on Figure 9. A retaining wall extends approximately 400 feet northerly from this stairway along the east side of the parking lot. Photos of this stairway are included in Appendix A.

The upper portion of the stairway is undermined by rodent burrows. The majority of the upper cap block layer of the concrete masonry unit (CMU) retaining wall is spalling and separating from the lower rows of block.

It is our opinion that erosion mitigation measures and/or modifications to this bluff-face area may be warranted. Such measures and/or modifications include infilling voids under the stairway, deterring rodent activity, and repairing or regrouting the upper cap blocks of the CMU wall.

## 7.7 Bluff-Top Sidewalk – Precast Sections

The northerly portion of the bluff-top concrete walkway consists of precast concrete sidewalk sections. The foundation supports for these precast sections are deteriorating (see photos in Appendix A). We understand that new foundations are planned. Preliminary geotechnical recommendations for the new foundation supports (and concrete slabs on grade) are provided below in Section 9.

## 7.8 Bluff-Top Sidewalk – Slab-on-Grade Sections

The bluff-top sidewalk constructed as concrete slabs on grade appears to be performing satisfactorily from a geotechnical standpoint. Replacement slabs on grade should be constructed in accordance with the recommendations provided below in Section 9.

## 7.9 Bluff-Toe Sidewalk, Curb, and Retaining Wall

The bluff-toe walkway was constructed as concrete slabs on grade and appears to be performing satisfactorily from a geotechnical standpoint. However, there are several hardscape features and ancillary structures that appear in need of repair and/or maintenance.

For example, the low curb along the easterly side of the southern portion of the bluff-toe walkway is locally cracked, and has spalled concrete and areas of exposed rebar. As such, consideration should be given to repairing portions of this curb. Likewise, while the 3.3-foot-high retaining wall along the easterly side of the bluff-toe walkway is performing satisfactorily from a geotechnical standpoint, consideration may be given to cleaning out the upper loose, accumulated sloughed soils in areas where there may be overtopping of the wall.

#### 7.10 Carlsbad Seawall

The Carlsbad Seawall was constructed along the westerly side of the bluff-toe walkway. The seawall appears to be performing satisfactorily from a geotechnical standpoint. However, we observed areas of concrete spalling, which appear to be associated with the corrosive nature of the marine environment and groundwater migration. Photos of the seawall are included in Appendix A.

### 8 **ENHANCEMENT OF SURFICIAL BLUFF STABILITY**

In general, the existing westerly facing bluff is approximately 30 feet in height with an overall gradient varying from about 1.5:1 to 2.5:1 (horizontal to vertical). Locally, in the erosion rills and gullies, slope inclinations are generally steeper than 1:1 and in some cases are near vertical. Soils comprising the slope, are generally very friable sands with low to insignificant amounts of cohesion. As such, these soils are susceptible to surface disturbance, which will eliminate any inherent cohesion, and result in accelerated mass wasting and erosion. In addition, the slope soils are susceptible to water erosion, as evidenced by the erosion rills and gullies that exist across the slope. Previous analyses characterized the slope soils as having a cohesion of 200 pounds per square foot (psf) and a friction angle of 37 degrees with a maximum inclination of 1.5:1. For these conditions, the gross stability of the slopes was computed to be 1.5 for static conditions and greater than 1.2 for a horizontal pseudo-static coefficient of 0.15 g.

Project-specific geotechnical analyses of the stability of the subject coastal bluff will be performed when the proposed repair schemes for the public access improvements are chosen. Indications of deep-seated bluff instability were not noted at the site. However, areas of oversteepened slope gradients, potential surficial instability, soil erosion, and sloughed soil accumulation were observed. Various methods to enhance the surficial bluff stability can be

considered. Following are brief discussions on some of the methods that we suggest for this coastal bluff.

### 8.1 Surface Water and Groundwater Control

Surface water and groundwater should be controlled on the bluff property. Surface waters should be managed so surface flow is not directed over the top of bluff and onto the bluff face. Based on the previous geotechnical reports, we understand that the upper walkway was sloped away from the bluff edge and storm drain pipes that discharged down the bluff face were abandoned. Various drainage provisions at the top of the bluff have been implemented. Drainage provisions should be periodically checked for blockage and cleared. The introduction of irrigation waters at the top of and on the coastal bluff should be maintained at the minimum necessary for plant vigor. Irrigation waters should not be allowed to saturate the surficial soils on the bluff face and/or migrate through bluff soils and develop groundwater seeps.

### 8.2 Vegetation and Irrigation System Maintenance

The vegetative cover on the coastal bluff ranges from nonexistent to dense. A coastal landscape architect/contractor may be consulted for an evaluation of the types of plants suitable to the bluff. The irrigation system and caged plants observed on site suggest that a revegetation effort is already underway. We recommend that disturbance of the bluff soils during planting remain minimal. Areas with indurated, cemented bluff soils should not be disturbed or planted. Routine inspection of the irrigation systems and prompt repair of broken lines and sprinkler heads should be implemented.

### 8.3 Rodent Control

Ground squirrels have burrowed into areas of the coastal bluff. Many squirrels (and a few rabbits) were observed on the bluff face during our site visits. Rodent burrowing and disturbance of the bluff soils are detrimental to the surficial stability of the bluff and the rodent activity should be deterred.



#### 8.4 **Installation of Retaining Structures**

Grading of those areas of the bluff face that are oversteepened is likely not a suitable option for stabilization of the surficial soils. Other options include installing small retaining structures, erodible concrete infills, or three-dimensional cellular confinement systems. Foundations should be constructed in accordance with the following recommendations.

### 9 PRELIMINARY FOUNDATION/SLAB RECOMMENDATIONS

This Geotechnical Basis of Design report has been prepared for the City of Carlsbad Beach Access Repairs. Following are our preliminary geotechnical recommendations for the design and construction of new foundation elements.

#### 9.1 **Foundation Design for Sidewalk Support/Retaining Walls**

Foundations should be designed in accordance with structural considerations and the following recommendations. These recommendations assume that the near-surface soils during foundation excavation have a very low to low expansion potential (based on ASTM D4829). These recommendations also assume that the on-site potentially compressible fill soils will not be used for support of the foundations for the proposed improvements. The foundation elements will be founded in dense formational soils (terrace deposits or Santiago Formation).

The proposed foundation elements for new and/or modified sidewalk foundations and any planned retaining walls may be supported by continuous and/or spread footings bearing entirely in dense formational soils at a minimum depth of 24 inches beneath the lowest adjacent grade with a minimum embedment of 12 inches into the formational soils. Continuous footings should have a minimum width of 15 inches and be reinforced, at a minimum, with four No. 5 rebars (two near the top and two near the footing bottom). Spread footings should be designed in accordance with structural considerations and have a minimum width of 24 inches. Foundation elements should have a minimum structural setback of 10 feet horizontally from the bluff face.

For strip and spread footings satisfying the above criteria, we recommend using an allowable bearing pressure of 2,000 psf. Footings and slabs founded entirely in dense formational soils

or entirely in compacted fill soils may be designed for a passive lateral pressure of 350 psf per foot of depth. This assumes that the outside face of the footing is located a minimum of 10 feet from the face of the slope. For foundations located nearer the slope face, we recommend using a passive earth pressure of 100 psf. These values are ultimate values. Lastly, we recommend using a coefficient of friction against sliding between concrete and soil of 0.3. These values may be increased by one-third when considering loads of short duration, such as wind and seismic forces.

## 9.2 Slab Design for On-Grade Sidewalk Slabs

Concrete slab-on-grade sidewalks should be designed in accordance with structural considerations and the following recommendations. Concrete slabs on grade underlain entirely by terrace deposits (or properly compacted fill soils) with a very low to low expansion potential should have a minimum thickness of 5 inches and be reinforced at mid-height with No. 3 rebars at 18 inches on center, each way. Care should be taken by the contractor to ensure that the reinforcement is placed at slab mid-height.

Slabs should be designed with crack control joints at appropriate spacing for the anticipated loading. Slabs should be underlain by a 2-inch layer of clean sand (sand equivalent greater than 30). The on-site sandy soils may be used for the underlying sand blanket if testing confirms a sand equivalent greater than 30. The potential for slab cracking may be lessened by careful control of water/cement ratios. The use of low slump concrete is recommended. Appropriate curing precautions should be taken during placement of concrete during hot weather. We recommend that the upper approximately one foot of soil beneath concrete slabs on grade be compacted to a minimum 95 percent relative compaction (ASTM D1557), and these subgrade soils should be moistened prior to placing the sand blanket and concrete.

Please note that our recommendations for foundations and slabs are minimum design parameters. The project structural engineer is responsible for final design of the foundations and concrete slabs on grade. In addition, our recommendations are not intended to eliminate the possibility of cracks due to concrete shrinkage. Shrinkage cracks develop in nearly all slabs that are not specifically designed to prevent them. We recommend that a structural consultant or qualified concrete contractor be consulted to provide appropriate design and workmanship requirements for mitigation of shrinkage cracks.

### 9.3 Retaining Walls

For retaining walls backfilled with on-site sandy soils, we recommend a lateral earth pressure of 35 pcf for retaining walls with a flat backfill condition and that are free to move sufficiently to develop active earth pressure conditions. For retaining walls with a flat backfill condition and that are restrained to lateral movement, we recommend using a lateral earth pressure expressed as an equivalent fluid pressure of 60 pcf.

We recommend that all retaining walls be provided with wall drainage systems to mitigate the development of hydrostatic water pressures. The walls should also be appropriately waterproofed. Design of waterproofing should be provided by the project civil engineer. Waterproofing should be protected during construction. Waterproofing treatments and alternative suitable wall drainage products are available commercially. Wall backfill should be compacted by mechanical means to at least 90 percent relative compaction (ASTM D1557). Care should be taken when using compaction equipment in close proximity to retaining walls so that the walls are not damaged by excessive compaction.

For walls subjected to area wide surcharges, we recommend using one-third of the area surcharge pressure as an additional lateral load for retaining walls that are free to develop active earth pressures and one-half of the area wide surface surcharge pressure for walls that are restrained. At a minimum, we recommend using an area surface surcharge pressure of 200 psf. However, we recommend that an assessment of potential surcharge loads be made to evaluate if this minimum pressure needs to be increased.

### 9.4 Structural Fill Placement

The on-site soils appear to be suitable for structural fill provided they are relatively free of organic material, debris, and rock fragments larger than 6 inches in maximum dimension. Areas to receive fill should be scarified to a minimum depth of 6 inches, brought to near-optimum moisture conditions, and compacted to at least 90 percent relative compaction, based on laboratory standard ASTM D1557. Fill soils should be brought to near-optimum moisture conditions and compacted in uniform lifts to at least 90 percent relative compaction (ASTM D1557). The optimum lift thickness to produce a uniformly compacted fill will depend on the size and type of construction equipment used. In general, fill should be placed in uniform lifts not exceeding 8 inches in loose thickness. Placement and compaction of fill should be observed and tested by the geotechnical consultant. In general, placement and

compaction of fill should be performed in accordance with local grading ordinances, sound construction practices, and the recommendations herein.

## 10 ADDITIONAL GEOTECHNICAL STUDIES

The conclusions provided in this report are based on surficial exposures of soils observed during our field visits and our review of geologic literature. Soils investigation services (including subsurface exploration and laboratory testing) to confirm site-specific geotechnical conditions have not been performed by TerraCosta. Evaluations of the presence of potentially expansive soils, corrosive soils, and compressible soils have not been performed. In addition to geotechnical investigation services that may be performed for any new construction, please note that evaluations of the coastal bluff, its stability, and the exact location of the bluff edge may be requested by the City of Carlsbad and California Coastal Commission (and possibly other regulatory agencies) to satisfy their regulatory requirements.

## 11 LIMITATIONS

The data provided in this report were collected from previously published reports/maps and our field observations of the existing surficial soil conditions. Subsurface exploration, geotechnical laboratory testing, and site-specific geotechnical analyses were not performed by TerraCosta for this Geotechnical Basis of Design report. Please note that this report may not satisfy applicable regulatory agency reviewer requirements. This report is not considered valid if changes in site conditions occur, and this report is not valid after two years after the date of this report.

This firm does not practice or consult in the field of safety engineering. We do not direct the contractor's operations, and we cannot be responsible for the safety of other than our own personnel on the site. Therefore, the safety of others is the responsibility of the contractor. The contractor should notify the owner if he considers any of the recommended actions presented herein to be unsafe.

## REFERENCES

1. California Emergency Management Agency, California Geological Survey and the University of Southern California, 2009, Tsunami Inundation Map for Emergency Planning, Oceanside Quadrangle/San Luis Rey Quadrangle, San Diego County, California, dated June 1.
2. California Geological Survey, 2018, Earthquake Fault Zones: A Guide for Government Agencies, Property Owners/Developers, and Geoscience Practitioners for Assessing Fault Rupture Hazards in California: CGS Special Publication 42 (revision of former Alquist-Priolo Fault-Rupture Hazard Zones).
3. California Geological Survey, 2010, Fault Activity Map of California and Adjacent Areas: Geological Data Map No. 6.
4. Kennedy, M.P., and S.S. Tan, 2007, Geologic Map of the Oceanside 30' x 60' Quadrangle, California: California Geological Survey Regional Geologic Map Series, Map No. 2 (online).
5. Tan, S.S., 1995, Landslide Hazards in the Northern Part of the San Diego Metropolitan Area, San Diego County, California: California Division of Mines and Geology, Open-File Report 95-04.
6. Weber, F.H., Jr., 1982, Recent Slope Failures, Ancient Landslides, and Related Geology of the North-Central Coastal Area, San Diego County, California; California Division of Mines and Geology, Open-File Report 82-12.
7. Woodward-Clyde Consultants, 1986, Geological Investigation for the Proposed Carlsbad Boulevard Seawall, Carlsbad, California (Appendix B – part of the contract documents for the Carlsbad Seawall).
8. Woodward-Clyde Consultants, 1987, Supplemental Geotechnical Data, Carlsbad Boulevard Promenade, Carlsbad, California, dated November 24.
9. Woodward-Clyde Consultants, in association with Safino, Butcher and Ormonde, Inc., 1986, Plans for the Construction of Carlsbad Blvd. Seawall (32 sheets) , dated July 1.
10. Woodward-Clyde Consultants, in association with Safino, Butcher and Ormonde, Inc., 1987, Plans for the Construction of Carlsbad Blvd. Promenade (14 sheets), dated August 31.



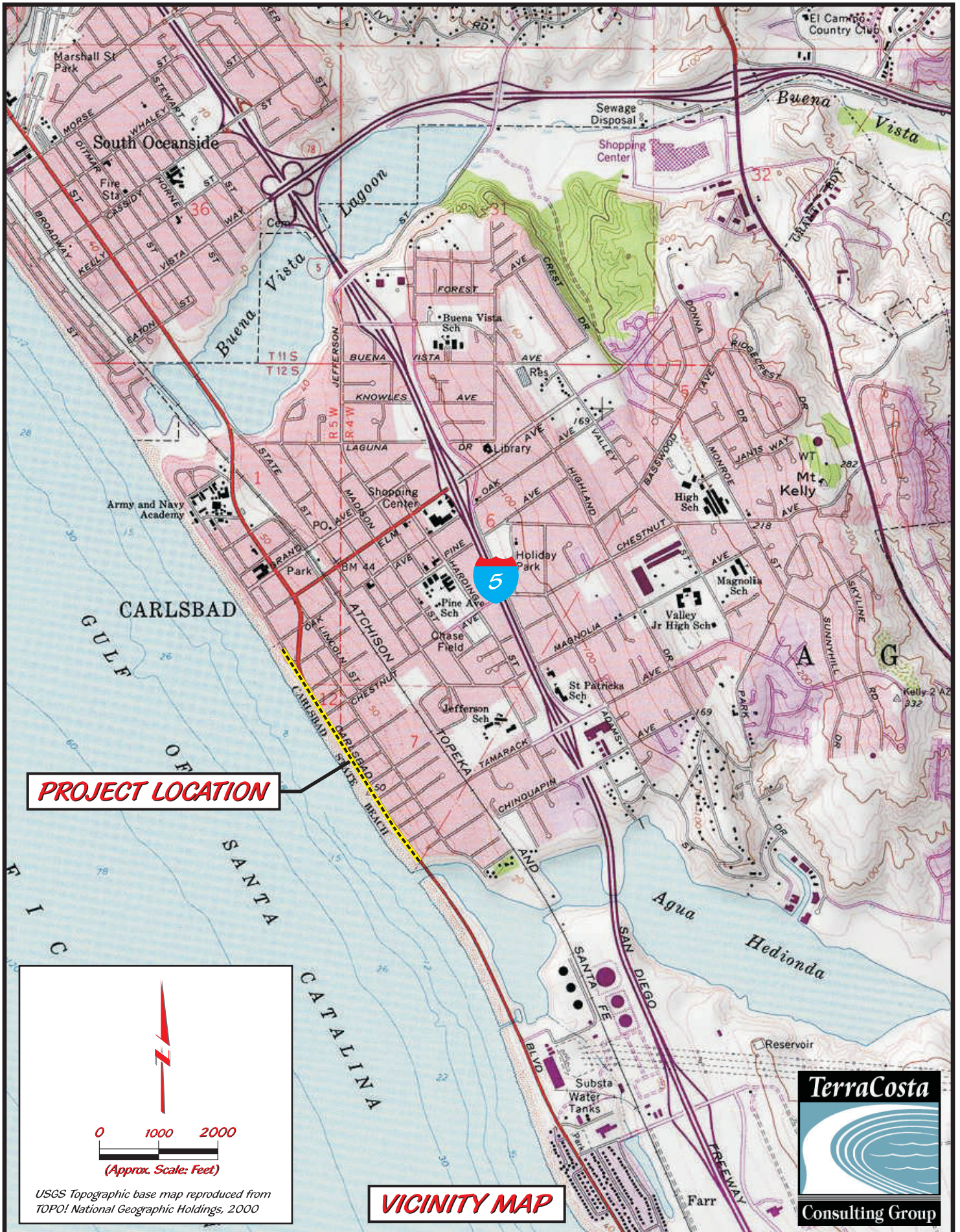



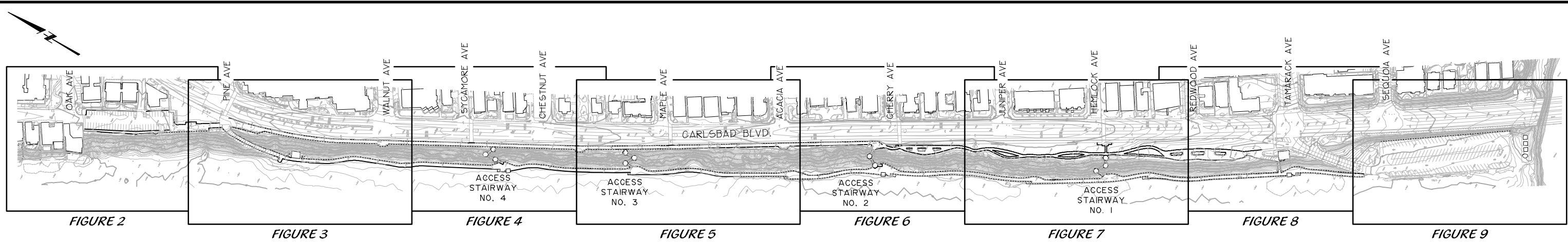

**KEY MAP**  
SCALE: 1"=300'

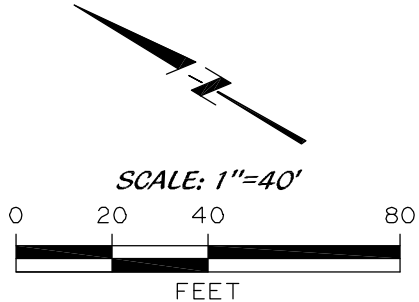

**LEGEND**

② → PHOTO NUMBER AND APPROXIMATE ORIENTATION AND DIRECTION



<b>TERRACOSTA CONSULTING GROUP</b> ENGINEERS AND GEOLOGISTS 3890 MURPHY CANYON ROAD, SUITE 200 SAN DIEGO, CA 92123 (858) 573-6900	FIGURE NUMBER <b>2</b>
PROJECT NAME <b>CITY OF CARLSBAD BEACH ACCESS REPAIRS</b>	PROJECT NUMBER <b>3009</b>

**PROJECT MAP**





PHOTO 3



PHOTO 4



PHOTO 5



PHOTO 6

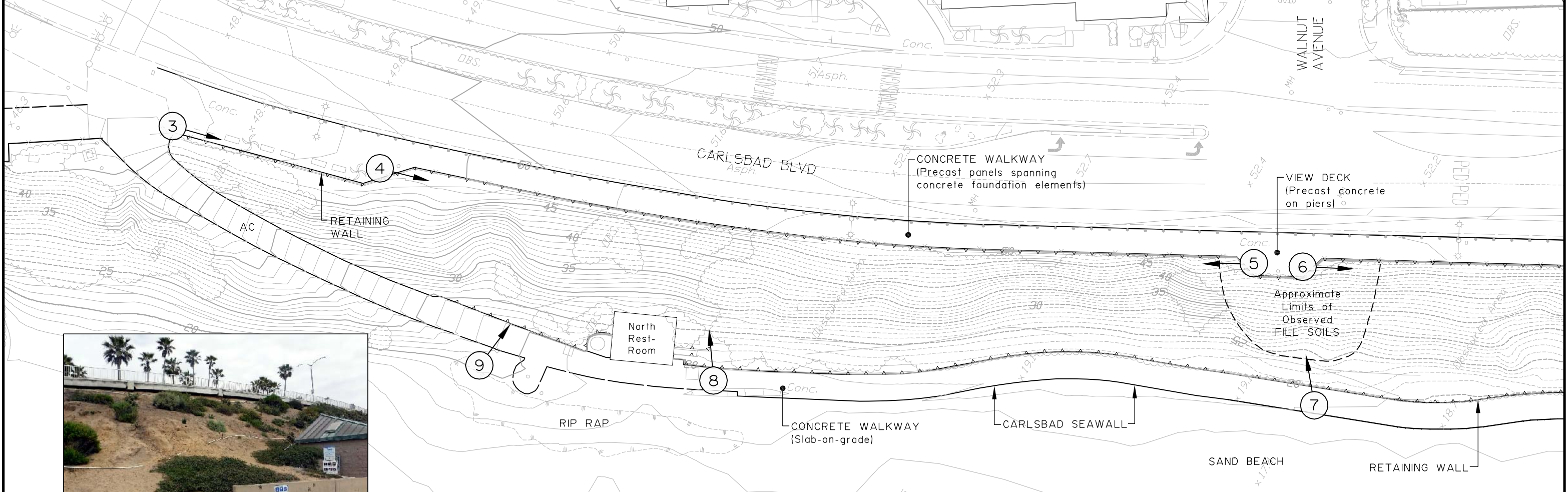

PHOTO 9



PHOTO 8



PHOTO 7

**LEGEND**

9 → PHOTO NUMBER AND APPROXIMATE ORIENTATION AND DIRECTION

SCALE: 1"=40'

0 20 40 80

FEET

	<b>TERRACOSTA CONSULTING GROUP</b> ENGINEERS AND GEOLOGISTS 3890 MURPHY CANYON ROAD, SUITE 200 SAN DIEGO, CA 92123 (858) 573-6900	FIGURE NUMBER <b>3</b>
	PROJECT NAME <b>CITY OF CARLSBAD BEACH ACCESS REPAIRS</b>	PROJECT NUMBER <b>3009</b>
<b>PROJECT MAP</b>		





**TERRACOSTA CONSULTING GROUP**  
 ENGINEERS AND GEOLOGISTS  
 3890 MURPHY CANYON ROAD, SUITE 200  
 SAN DIEGO, CA 92123 (858) 573-6900

PROJECT NAME  
**CITY OF CARLSBAD  
 BEACH ACCESS REPAIRS**

FIGURE NUMBER  
**4**

PROJECT NUMBER  
**3009**

**PROJECT MAP**



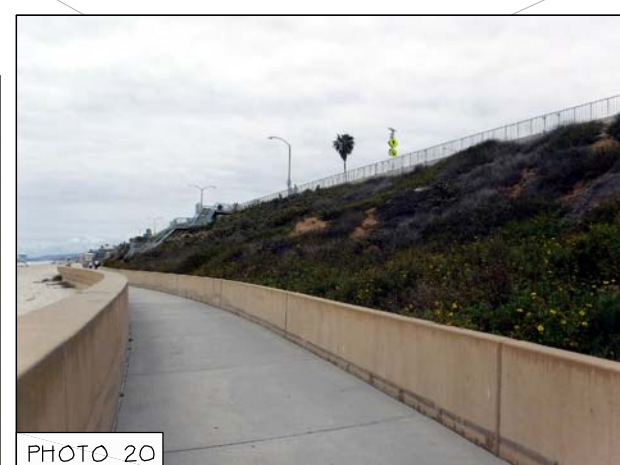
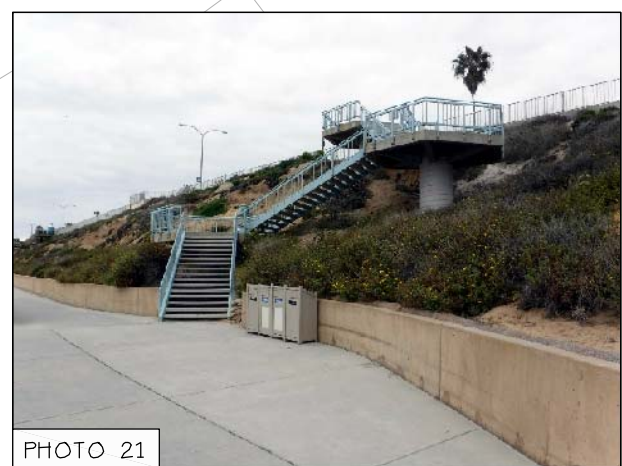
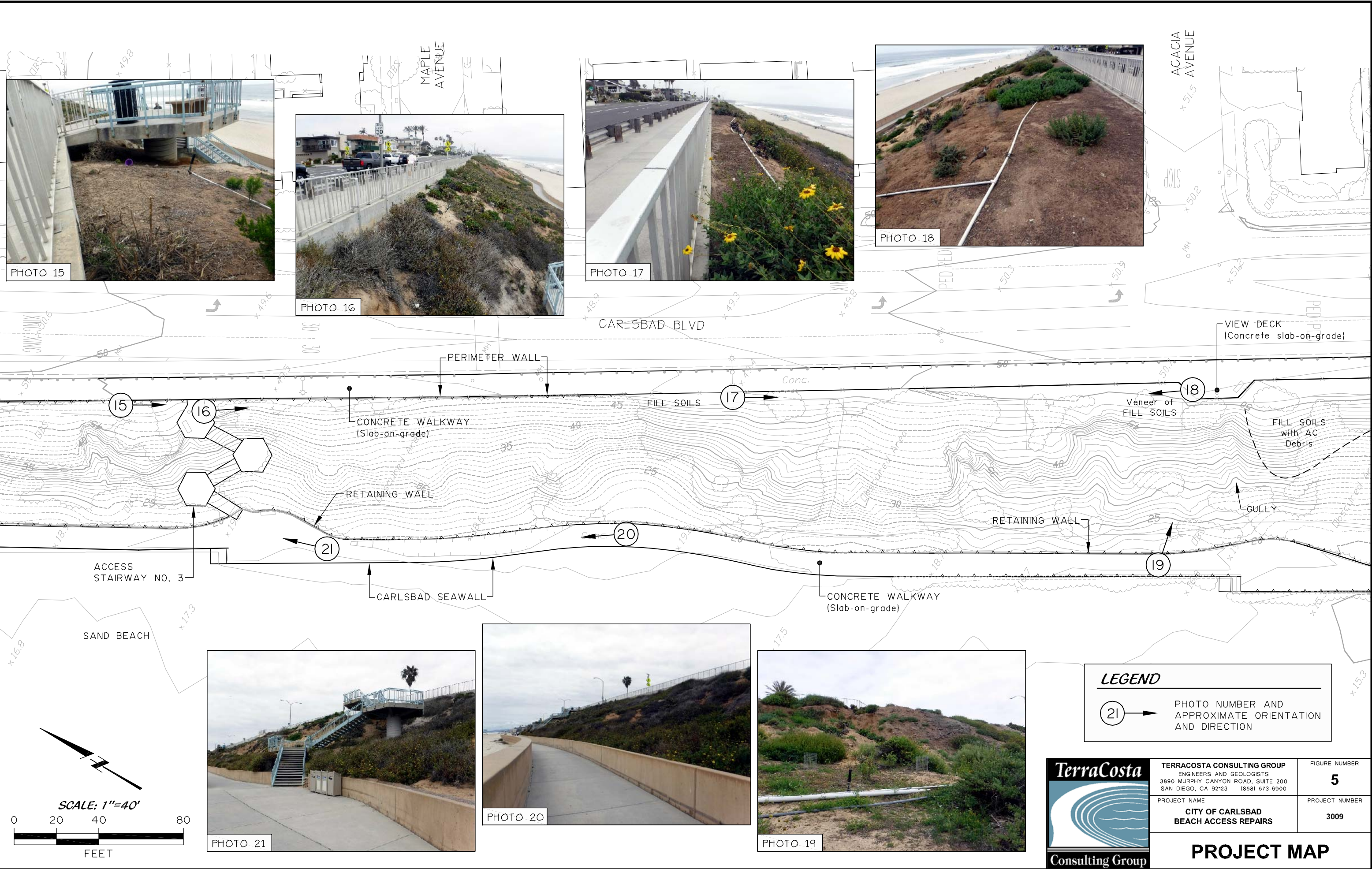

**LEGEND**

(21) → PHOTO NUMBER AND APPROXIMATE ORIENTATION AND DIRECTION

	<b>TERRACOSTA CONSULTING GROUP</b> ENGINEERS AND GEOLOGISTS 3890 MURPHY CANYON ROAD, SUITE 200 SAN DIEGO, CA 92123 (858) 573-6900	FIGURE NUMBER
	PROJECT NAME <b>CITY OF CARLSBAD BEACH ACCESS REPAIRS</b>	<b>5</b>
		PROJECT NUMBER
		<b>3009</b>
<b>PROJECT MAP</b>		

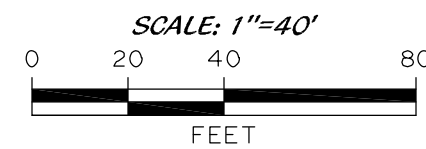



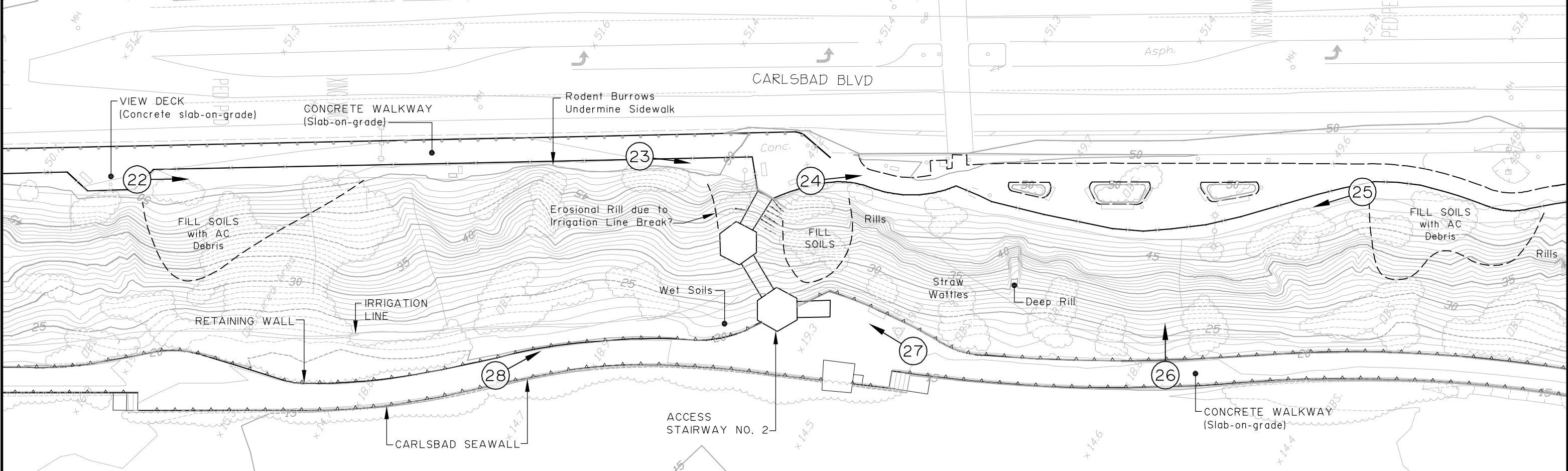

**LEGEND**

28 → PHOTO NUMBER AND APPROXIMATE ORIENTATION AND DIRECTION

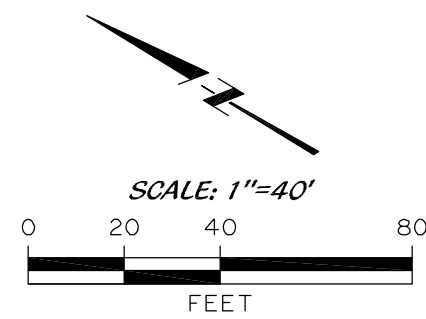

**TerraCosta Consulting Group**  
ENGINEERS AND GEOLOGISTS  
3890 MURPHY CANYON ROAD, SUITE 200  
SAN DIEGO, CA 92123 (858) 573-6900

PROJECT NAME  
**CITY OF CARLSBAD BEACH ACCESS REPAIRS**

FIGURE NUMBER  
**6**

PROJECT NUMBER  
**3009**

**PROJECT MAP**



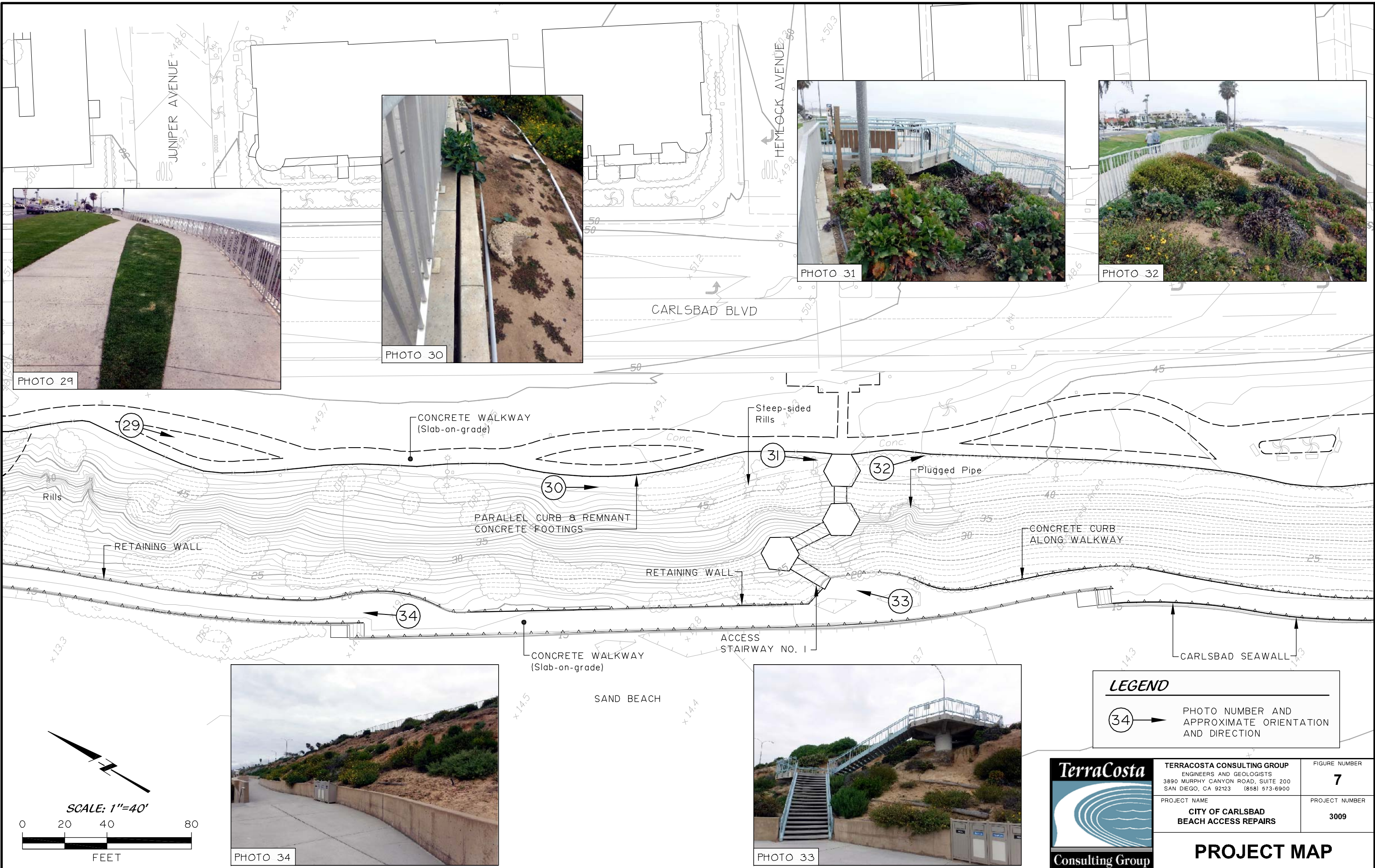

PHOTO 29

PHOTO 30

PHOTO 31

PHOTO 32

PHOTO 34

PHOTO 33

**LEGEND**

34 → PHOTO NUMBER AND APPROXIMATE ORIENTATION AND DIRECTION

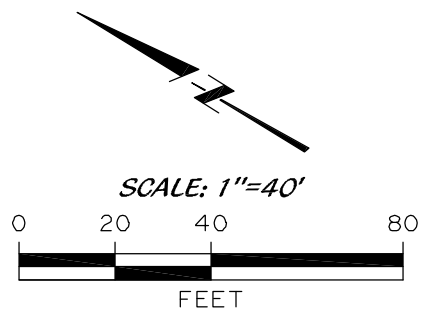

<b>TERRACOSTA CONSULTING GROUP</b> ENGINEERS AND GEOLOGISTS 3890 MURPHY CANYON ROAD, SUITE 200 SAN DIEGO, CA 92123 (858) 573-6900		FIGURE NUMBER <b>7</b>
PROJECT NAME <b>CITY OF CARLSBAD          BEACH ACCESS REPAIRS</b>		PROJECT NUMBER <b>3009</b>

**PROJECT MAP**



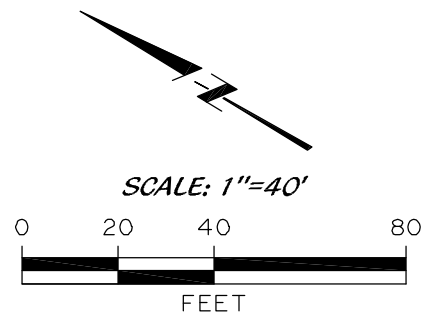

LEGEND	
	PHOTO NUMBER AND APPROXIMATE ORIENTATION AND DIRECTION

	<b>TERRACOSTA CONSULTING GROUP</b> ENGINEERS AND GEOLOGISTS 3890 MURPHY CANYON ROAD, SUITE 200 SAN DIEGO, CA 92123 (858) 573-6900	FIGURE NUMBER <b>8</b>
	PROJECT NAME <b>CITY OF CARLSBAD          BEACH ACCESS REPAIRS</b>	PROJECT NUMBER <b>3009</b>
<b>PROJECT MAP</b>		



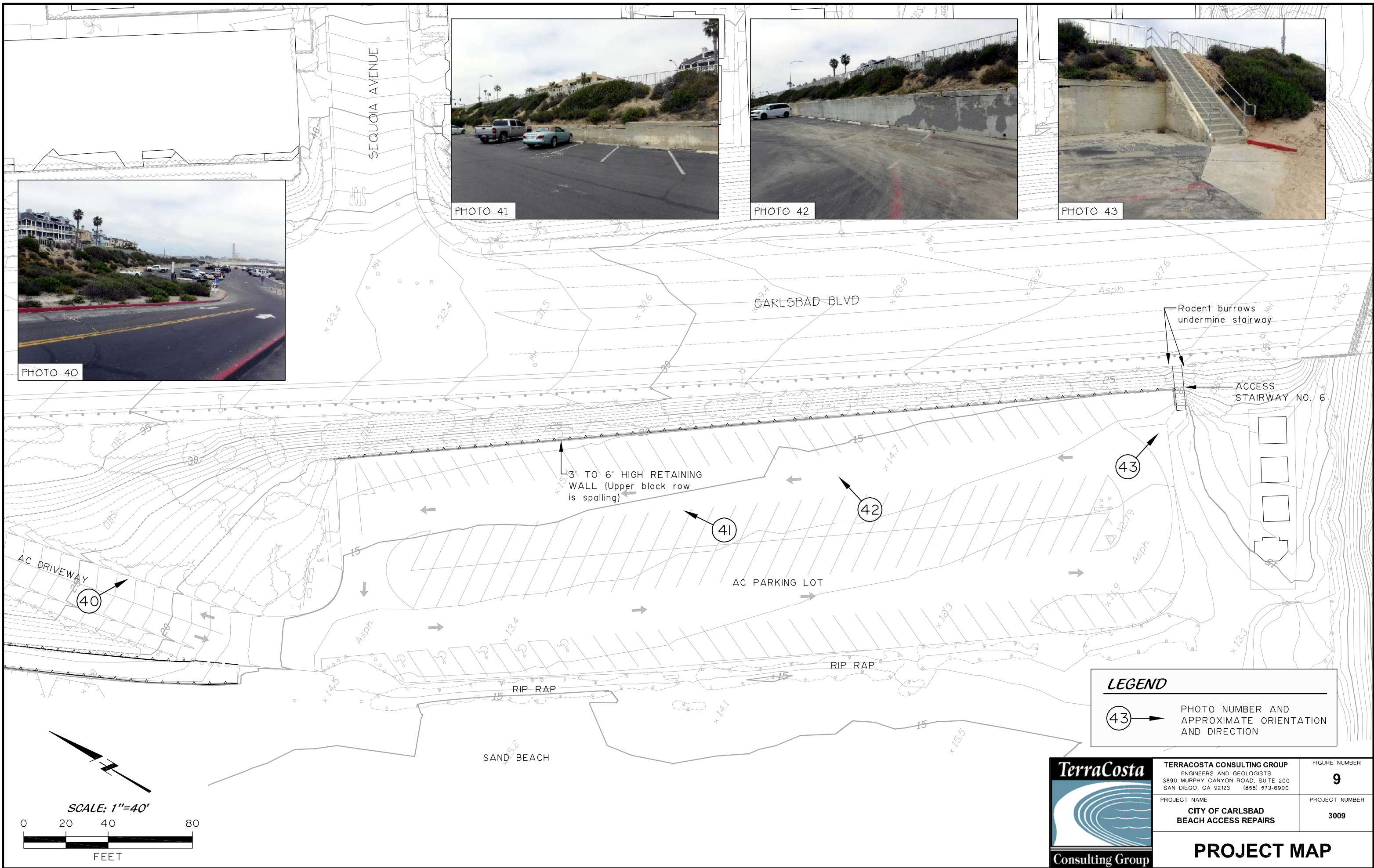

**LEGEND**

④3 → PHOTO NUMBER AND APPROXIMATE ORIENTATION AND DIRECTION



**TERRACOSTA CONSULTING GROUP**  
ENGINEERS AND GEOLOGISTS  
3890 MURPHY CANYON ROAD, SUITE 200  
SAN DIEGO, CA 92123 (858) 573-6900

FIGURE NUMBER  
**9**

PROJECT NAME  
**CITY OF CARLSBAD  
BEACH ACCESS REPAIRS**

PROJECT NUMBER  
**3009**

**PROJECT MAP**

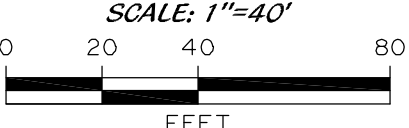



**BASE MAP SOURCE:**  
 Adapted from a portion of "Geologic Map of the Oceanside 30'x60' Quadrangle, California," compiled by Michael P. Kennedy and Siang S. Tan, 2007. California Geological Survey.

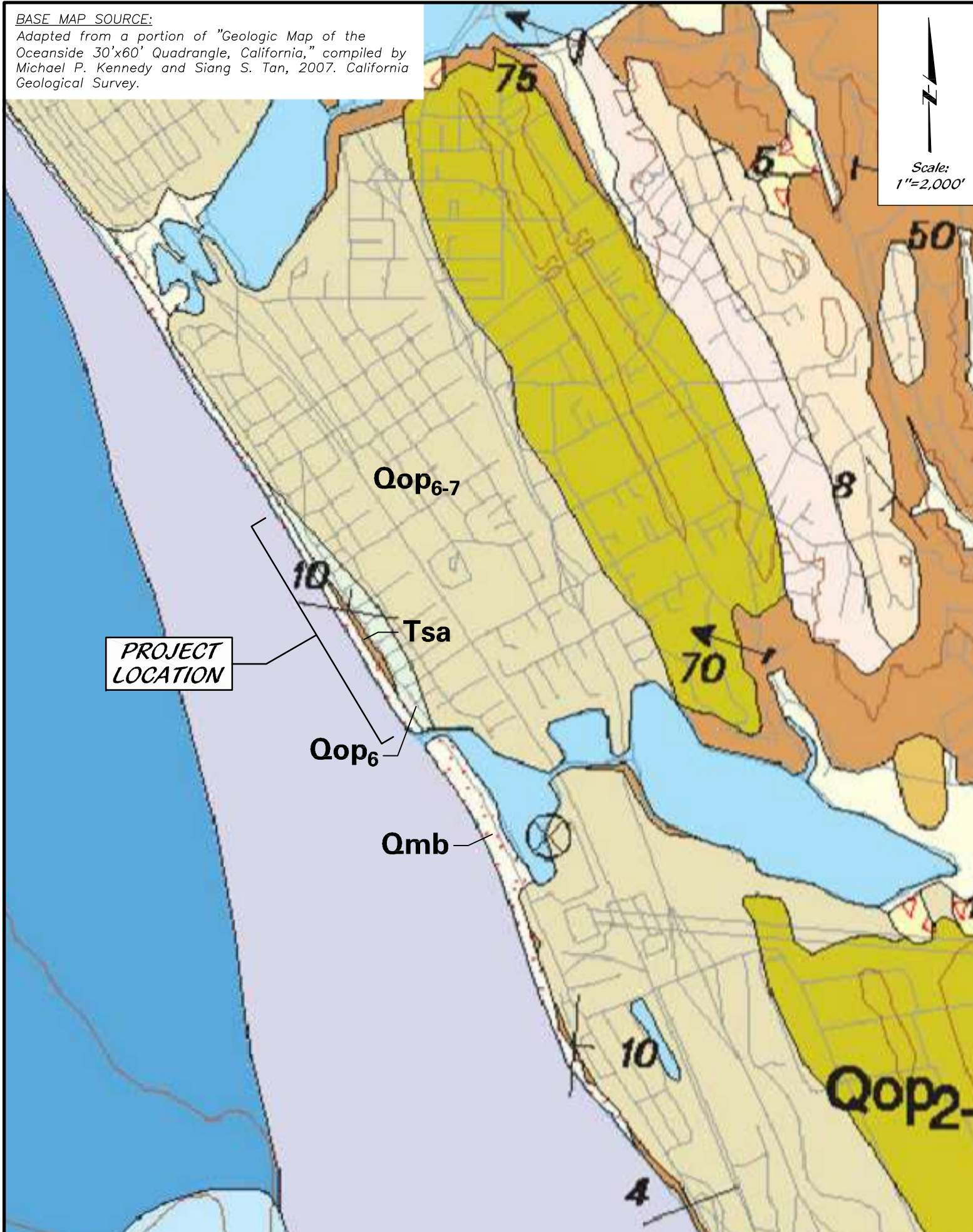

### GEOLOGIC UNITS

- Qmb Marine beach deposits (late Holocene) - Unconsolidated beach deposits consisting mostly of fine- and medium-grained sand.
- Qop7 Old paralic deposits, Unit 7 (late to middle Pleistocene) - Poorly sorted, moderately permeable, reddish-brown, interfingered strandline, beach, estuarine and colluvial deposits composed of siltstone, sandstone and conglomerate. These deposits rest on the 9-11 m Bird Rock terrace.
- Qop6 Old paralic deposits, Unit 6 (late to middle Pleistocene) - Poorly sorted, moderately permeable, reddish-brown, interfingered strandline, beach, estuarine and colluvial deposits composed of siltstone, sandstone and conglomerate. These deposits rest on the 22-23 m Nestor terrace.
- Tsa Santiago Formation (middle Eocene) - There are three distinctive parts. A basal member consisting of buff and brownish-gray, massive, coarse-grained, poorly sorted arkosic sandstone and conglomerate (sandstone generally predominating). In some areas the basal member is overlain by a central member that consists of gray and brownish-gray (salt and pepper) soft, medium-grained, moderately well sorted arkosic sandstone. The upper member consists of gray, coarse-grained arkosic sandstone and grit. Vertically and laterally throughout the formation there exists greenish-brown, massive claystone interbeds, tongues and lenses of often fossiliferous, lagoonal claystone and siltstone.

	<b>TERRACOSTA CONSULTING GROUP</b> ENGINEERS AND GEOLOGISTS 3890 MURPHY CANYON ROAD, SUITE 200 SAN DIEGO, CA 92123 (858) 573-6900	FIGURE NUMBER <b>10</b>
	PROJECT NAME <b>CITY OF CARLSBAD          BEACH ACCESS REPAIRS</b>	PROJECT NUMBER <b>3009</b>
<b>REGIONAL GEOLOGIC MAP</b>		



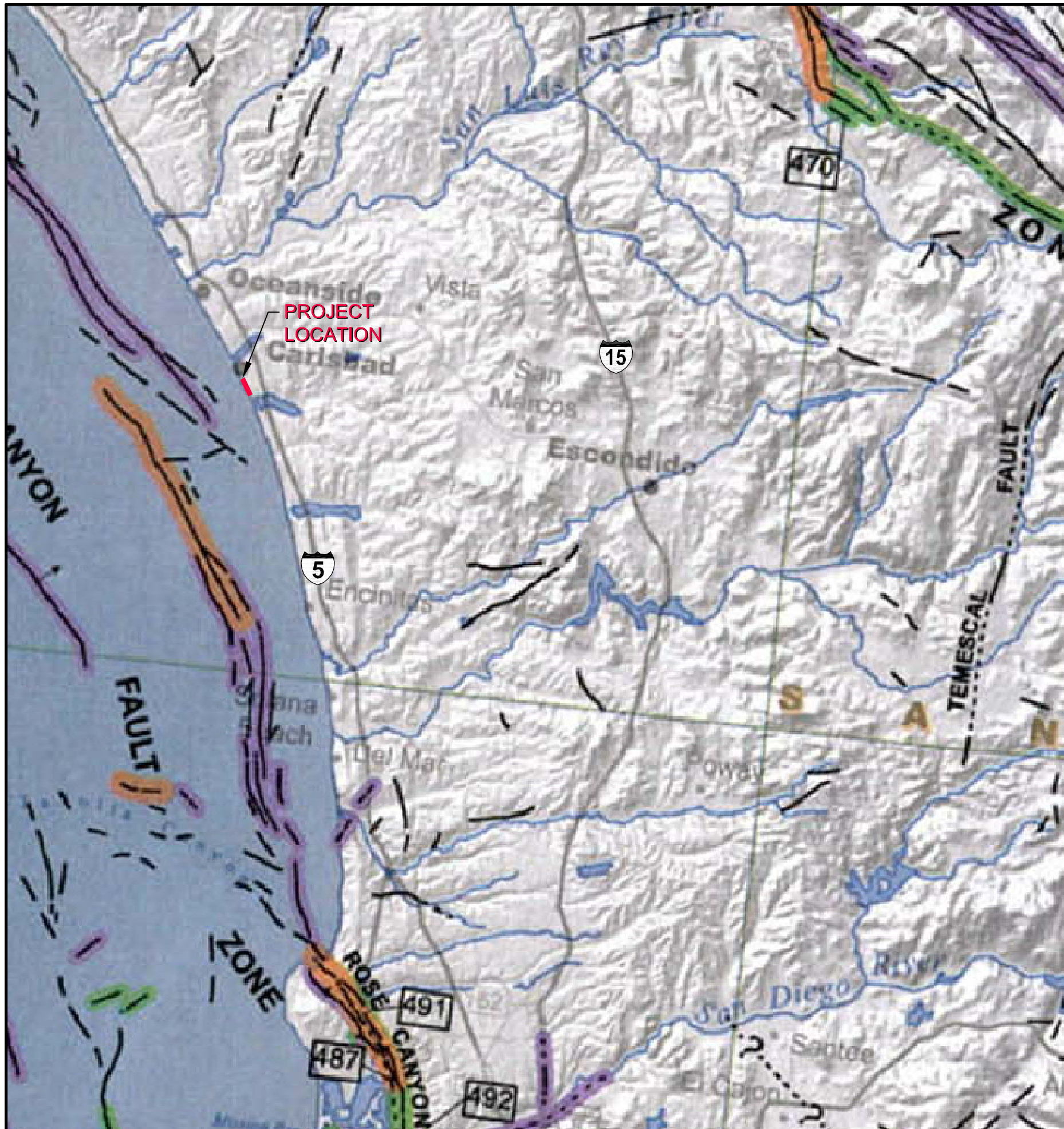

**EXPLANATION**

Fault traces on land are indicated by solid lines where well located, by dashed lines where approximately located or inferred, and by dotted lines where concealed by younger rocks or by lakes or bays. Fault traces are queried where continuation or existence is uncertain. Concealed faults in the Great Valley are based on maps of selected subsurface horizons, so locations shown are approximate and may indicate structural trend only. All offshore faults based on seismic reflection profile records are shown as solid lines where well defined, dashed where inferred, queried where uncertain.

**FAULT CLASSIFICATION COLOR CODE**  
(Indicating Recency of Movement)

- Fault along which historic (last 200 years) displacement has occurred and is associated with one or more of the following:
  - (a) a recorded earthquake with surface rupture. (Also included are some well-defined surface breaks caused by ground shaking during earthquakes, e.g. extensive ground breakage, not on the White Wolf fault, caused by the Arvin-Tehachapi earthquake of 1952). The date of the associated earthquake is indicated. Where repeated surface ruptures on the same fault have occurred, only the date of the latest movement may be indicated, especially if earlier reports are not well documented as to location of ground breaks.
  - (b) fault creep slippage - slow ground displacement usually without accompanying earthquakes.
  - (c) displaced survey lines.
- A triangle to the right or left of the date indicates termination point of observed surface displacement. Solid red triangle indicates known location of rupture termination point. Open black triangle indicates uncertain or estimated location of rupture termination point.
- Date bracketed by triangles indicates local fault break.
- No triangle by date indicates an intermediate point along fault break.
- Fault that exhibits fault creep slippage. Hachures indicate linear extent of fault creep. Annotation (creep with leader) indicates representative locations where fault creep has been observed and recorded.
- Square on fault indicates where fault creep slippage has occurred that has been triggered by an earthquake on some other fault. Date of causative earthquake indicated. Squares to right and left of date indicate terminal points between which triggered creep slippage has occurred (creep either continuous or intermittent between these end points).
- Holocene fault displacement (during past 11,700 years) without historic record. Geomorphic evidence for Holocene faulting includes sag ponds, scarps showing little erosion, or the following features in Holocene age deposits: offset stream courses, linear scarps, shutter ridges, and triangular faceted spurs. Recency of faulting offshore is based on the interpreted age of the youngest strata displaced by faulting.
- Late Quaternary fault displacement (during past 700,000 years). Geomorphic evidence similar to that described for Holocene faults except features are less distinct. Faulting may be younger, but lack of younger overlying deposits precludes more accurate age classification.
- Quaternary fault (age undifferentiated). Most faults of this category show evidence of displacement sometime during the past 1.6 million years; possible exceptions are faults which displace rocks of undifferentiated Plio-Pleistocene age. Unnumbered Quaternary faults were based on Fault Map of California, 1975. See Bulletin 201, Appendix D for source data.
- Pre-Quaternary fault (older than 1.6 million years) or fault without recognized Quaternary displacement. Some faults are shown in this category because the source of mapping used was of reconnaissance nature, or was not done with the object of dating fault displacements. Faults in this category are not necessarily inactive.

**ADDITIONAL FAULT SYMBOLS**

- Bar and ball on downthrown side (relative or apparent).
- Arrows along fault indicate relative or apparent direction of lateral movement.
- Arrow on fault indicates direction of dip.
- Low angle fault (barbs on upper plate). Fault surface generally dips less than 45° but locally may have been subsequently steepened. On offshore faults, barbs simply indicate a reverse fault regardless of steepness of dip.

**OTHER SYMBOLS**

- Numbers refer to annotations listed in the appendices of the accompanying report. Annotations include fault name, age of fault displacement, and pertinent references including Earthquake Fault Zone maps where a fault has been zoned by the Alquist-Priolo Earthquake Fault Zoning Act. This Act requires the State Geologist to delineate zones to encompass faults with Holocene displacement.
- Structural discontinuity (offshore) separating differing Neogene structural domains. May indicate discontinuities between basement rocks.
- Brawley Seismic Zone, a linear zone of seismicity locally up to 10 km wide associated with the releasing step between the Imperial and San Andreas faults.

**BASE MAP SOURCE:**  
Adapted from a portion of "Fault Activity Map of California, 2010 (CGS 150th Anniversary)" by Charles W. Jennings and William A. Bryant.

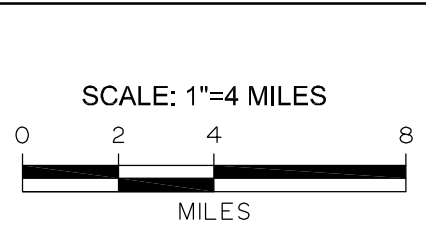

**TERRACOSTA CONSULTING GROUP**  
ENGINEERS AND GEOLOGISTS  
3890 MURPHY CANYON ROAD, SUITE 200  
SAN DIEGO, CA 92123 (858) 573-6900

FIGURE NUMBER  
**11**

PROJECT NAME  
**CITY OF CARLSBAD  
BEACH ACCESS REPAIRS**

PROJECT NUMBER  
**3022**

**REGIONAL FAULT MAP**



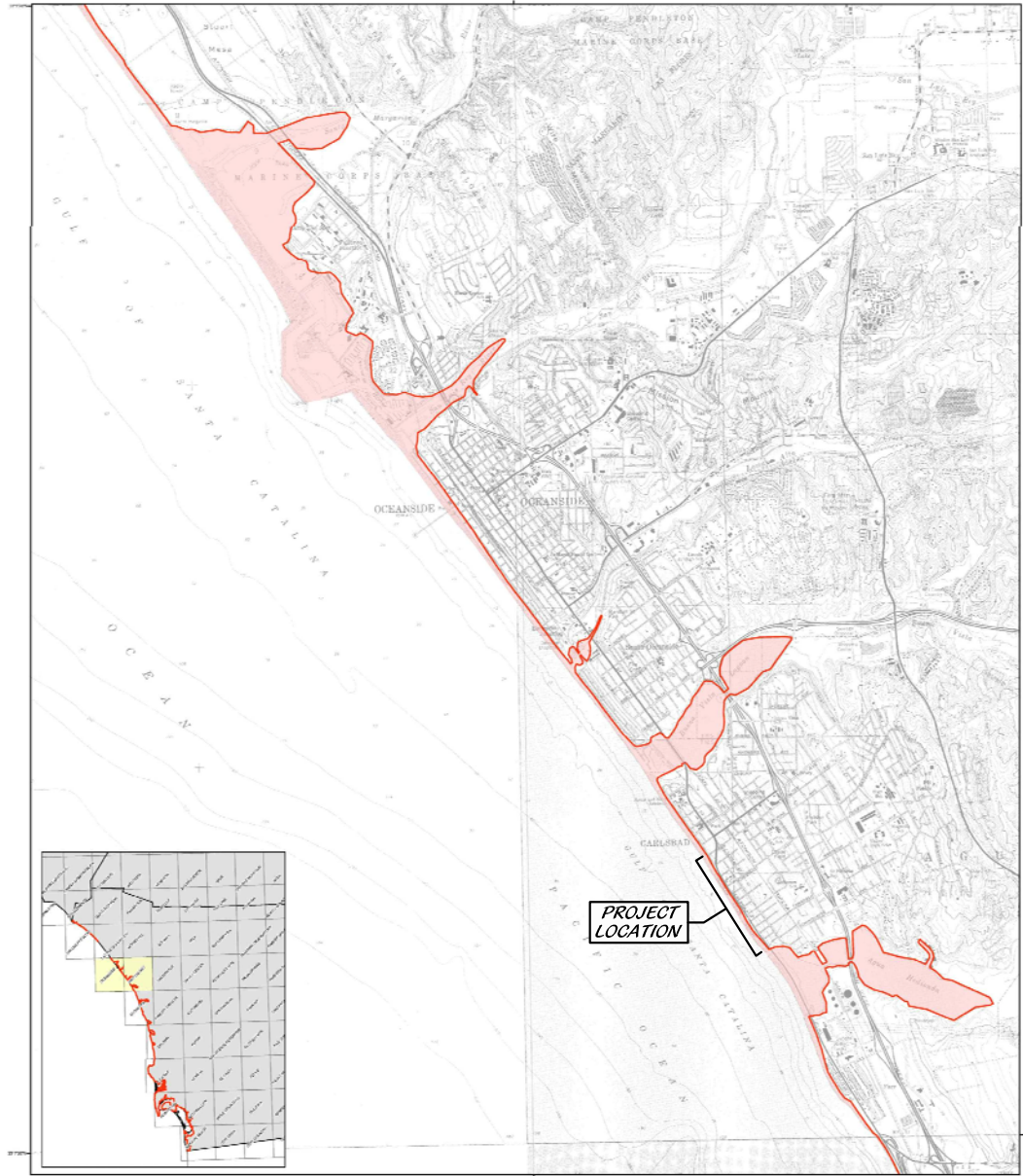

### METHOD OF PREPARATION

Initial tsunami modeling was performed by the University of Southern California (USC) Tsunami Program in Corvallis, Oregon through the California Emergency Management Agency (CEMA) by the National Tsunami Hazard Mitigation Program. The tsunami modeling program utilized the MOST (Method of Splitting Tsunami) computational program (Dawson et al., 2003) which allows for wave evaluation over a variable bathymetry and topography used for the inundation mapping (Tiwari and Swaminath, 1997; Tiwari and Synolakis, 1998).

The bathymetographic data that were used in the tsunami model consist of a series of control grids. Near-shore grids with a 5-m resolution (15- to 30-meter) resolution or higher were adjusted to "black" higher resolution conditions, representing a conservative sea level for the intended use of the tsunami modeling and mapping.

A suite of tsunami source events was selected for modeling, representing realistic local and distant earthquake and hypothetical extreme scenarios. Near-shore tsunamis include (1) local tsunami sources that were considered include offshore strike-slip thrust faults, spreading basins on strike-slip fault zones and large submarine landslides capable of significant offshore displacement and tsunami generation. Distant tsunami sources that were considered include great subduction zone events that are known to have occurred historically (1900 Chile and 1964 Alaska earthquakes) and others which can occur around the Pacific Ocean "Ring of Fire."

In order to enhance the recall from the 75- to 300-meter resolution grid data, a method was developed utilizing higher resolution digital topographic data (5- to 10-meter resolution) that better define the location of the maximum inundation line (U.S. Geological Survey, 1993; International, 2000; NOAA, 2000). The location of the maximum inundation line was determined by using digital imagery and terrain data on a GIS platform with consideration given to historic inundation information (Lander et al., 1981). This information was verified, where possible, by field work conducted with local county personnel.

The accuracy of the inundation line shown on these maps is subject to limitations in the accuracy and completeness of available bathymetric and tsunami source information, and the current understanding of tsunami generation and propagation phenomena are captured in the model. Thus, although an attempt has been made to identify a realistic upper bound to inundation at any location along the coastline, it remains possible that actual inundation could be greater in a major tsunami event.

This map does not represent inundation from a single scenario event. It was created by modeling inundation results for an ensemble of source events affecting a given region (Table 1). For 774 sources, 41 of the inundation regions in a particular area will likely be inundated during a single tsunami event.

**References**

Intermap Technology, Inc., 2003, Intermap product handbook and quick start guide, Intermap, NE/Tsingi, document on CD-ROM resolution data, 152 p.

Lander, J.E., Lockridge, P.A., and Kinoshita, M.J., 1981, Tsunami affecting the West Coast of the United States 1825-1952, National Oceanographic Data Center Key to Geophysical Record Description No. 78, NOAA NFD-55, NODC, 240 p.

National Atmospheric and Oceanic Administration (NOAA), 2000, Interim/interim Briefing/Agenda Reader (ISBAR) Digital Elevation Models from GeosAR Platform (EarthData) 3-minute resolution data.

Noaa, V.V., and Swaminath, C.L., 1997, Implementation and testing of the Method of Splitting Tsunami (MOST), NOAA Technical Memorandum FSI P-97-11, 11 p.

Tiwari, V.V., and Synolakis, C.L., 1996, Numerical modeling of tsunamis wave propagation, Journal of Offshore and Ocean Engineering, 20(4), pp 160-171.

U.S. Geological Survey, 1993, Digital Elevation Model, National Mapping Program, Technical Instructions, Data Users Guide 5, 49 p.

### TSUNAMI INUNDATION MAP FOR EMERGENCY PLANNING

### State of California ~ County of San Diego OCEANSIDE QUADRANGLE SAN LUIS REY QUADRANGLE

June 1, 2009

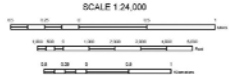

Table 1: Tsunami sources modeled for the San Diego County coastline.

Source (M = moment magnitude used in modeled event)	Areas of Inundation Map Coverage and Source Used		
	Oceanside	San Diego	San Luis Rey
Central Trough Fault	X	X	X
Central Fault	X	X	X
Comstock Reef Fault	X	X	X
Lanero Strait Fault	X	X	X
San Clemente Strait Fault	X	X	X
San Mateo Strait Fault	X	X	X
Central Oregon Landslide #1	X	X	X
Cascadia Subduction Zone #3 (192-2)	X	X	X
Central America Subduction Zone #1 (192-2)	X	X	X
Central America Subduction Zone #2 (192-2)	X	X	X
Central America Subduction Zone #3 (192-2)	X	X	X
China North Subduction Zone #1 (192-4)	X	X	X
1992 Chile Earthquake #1 (192-5)	X	X	X
1952 Kamoharui Earthquake #2 (192-5)	X	X	X
1994 Alaska Earthquake #3 (192-2)	X	X	X
Japan Subduction Zone #4 (192-2)	X	X	X
Karl Wendat Subduction Zone #3 (192-2)	X	X	X
Karl Wendat Subduction Zone #4 (192-2)	X	X	X

### MAP EXPLANATION

- Tsunami Inundation Line
- Tsunami Inundation Area

### PURPOSE OF THIS MAP

This tsunami inundation map was prepared to assist cities and counties in identifying their tsunami hazard. It is intended for local jurisdictional, capital evacuation planning and only. This map and the information presented herein is not a legal document and does not meet disclosure requirements for real estate transactions nor for any other regulatory process.

The inundation map has been compiled with best currently available scientific information. The inundation line represents the maximum potential tsunami range from a number of extreme, yet realistic, tsunami scenarios. Tsunamis are rare events due to a lack of known occurrences in the historical record. This map includes no information about the probability of any tsunami affecting any area within a specific period of time.

Please refer to the following websites for additional information on the construction and intended use of the tsunami inundation map:

State of California Emergency Management Agency, Earthquake and Tsunami Program  
<http://www.cema.ca.gov/EMAP/Pages/tsunami%20inundation%20map.aspx>

University of Southern California, Tsunami Research Center  
<http://www.usc.edu/earth/tsunami/2005/index.htm>

State of California Geological Survey Tsunami Information  
<http://www.conservation.ca.gov/geologic/geologic/tsunami/index.htm>

National Oceanic and Atmospheric Administration Center for Tsunami Research (MOST) map  
<http://link.noaa.gov/geoserver/geoserver/ows?service=WMS&request=GetMap&version=1.0.0>

### MAP BASE

Topographic base maps prepared by U.S. Geological Survey as part of the 7.5-minute Quadrangle Map Series (originally 1:50,000 scale). Tsunami inundation line boundaries may reflect updated digital orthophotographic and topographic data that can differ significantly from contours shown on the base map.

### DISCLAIMER

The California Emergency Management Agency (CEMA), the University of Southern California (USC), and the California Geological Survey (CGS) make no representation or warranties regarding the accuracy of the inundation map or the data from which the map was derived. Neither the State of California nor any of its counties, cities, or counties, nor any of its agencies, shall be liable under any circumstances for any claims, damages, or losses, including reasonable attorneys' fees, with respect to any claims by any user of any third party on account of or arising from the use of this map.

FIGURE NUMBER

12A

PROJECT NUMBER



3009



# TSUNAMI INUNDATION MAP OCEANSIDE/SAN LUIS REY



**MAP EXPLANATION**

-  Tsunami Inundation Line
-  Tsunami Inundation Area



Scale:  
1"=2,000'

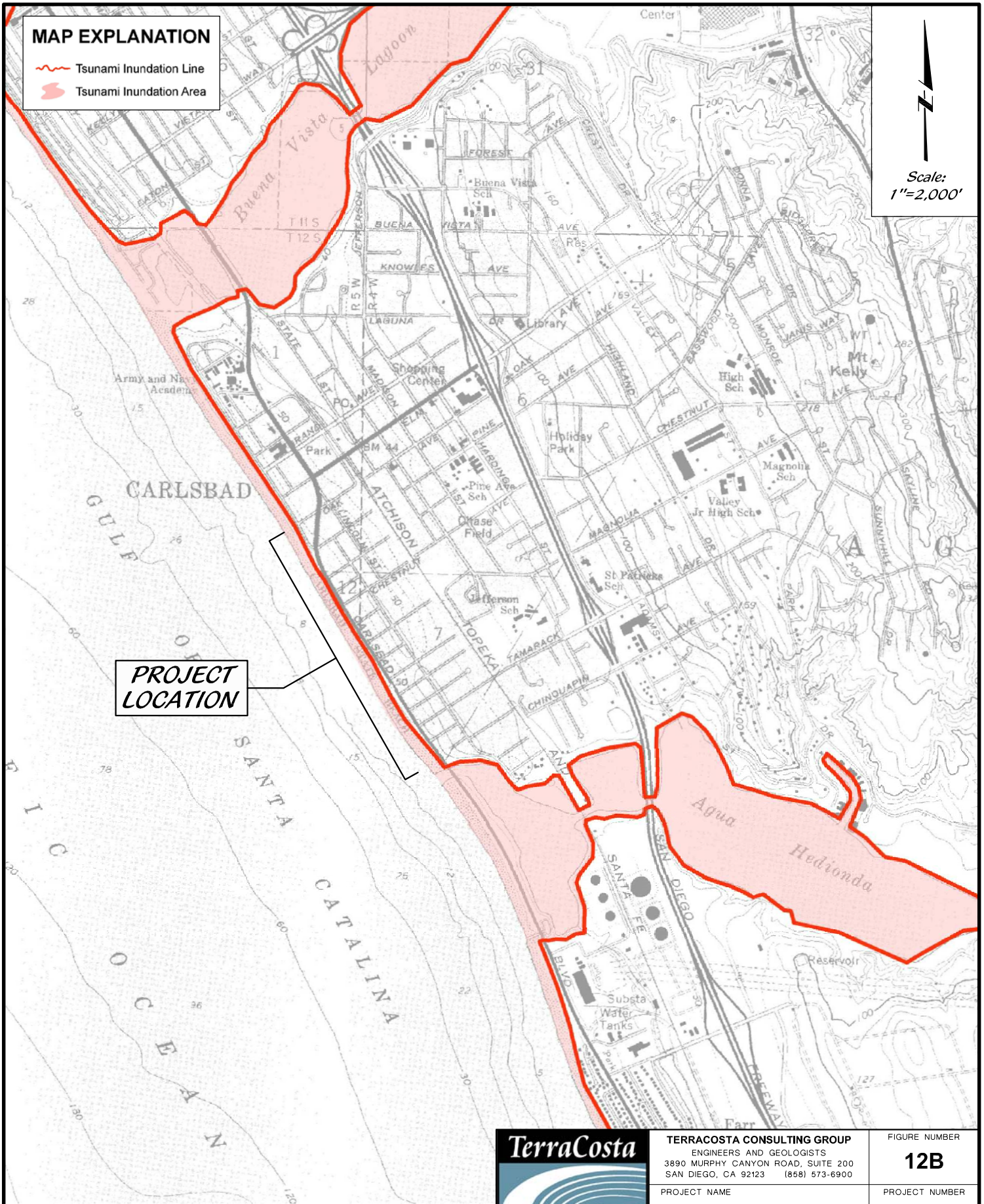

**PROJECT  
LOCATION**



**TERRACOSTA CONSULTING GROUP**  
ENGINEERS AND GEOLOGISTS  
3890 MURPHY CANYON ROAD, SUITE 200  
SAN DIEGO, CA 92123 (858) 573-6900

FIGURE NUMBER  
**12B**

PROJECT NAME  
**CITY OF CARLSBAD  
BEACH ACCESS REPAIRS**

PROJECT NUMBER  
**3009**

Reproduced from: "Tsunami Inundation Map for Emergency Planning, Oceanside Quadrangle, San Luis Rey Quadrangle," by the State of California, County of San Diego, dated June 1, 2009.

**TSUNAMI INUNDATION MAP**



## METHOD OF PREPARATION

Initial tsunami modeling was performed by the University of Southern California (USC) Tsunami Research Center funded through the California Emergency Management Agency (CalEMA) by the National Tsunami Hazard Mitigation Program. The tsunami modeling process utilized the MOST (Method of Splitting Tsunamis) computational program (Version 0), which allows for wave evolution over a variable bathymetry and topography used for the inundation mapping (Titov and Gonzalez, 1997; Titov and Synolakis, 1998).

The bathymetric/topographic data that were used in the tsunami models consist of a series of nested grids. Near-shore grids with a 3 arc-second (75- to 90-meters) resolution or higher, were adjusted to "Mean High Water" sea-level conditions, representing a conservative sea level for the intended use of the tsunami modeling and mapping.

A suite of tsunami source events was selected for modeling, representing realistic local and distant earthquakes and hypothetical extreme undersea, near-shore landslides (Table 1). Local tsunami sources that were considered include offshore reverse-thrust faults, restraining bends on strike-slip fault zones and large submarine landslides capable of significant seafloor displacement and tsunami generation. Distant tsunami sources that were considered include great subduction zone events that are known to have occurred historically (1960 Chile and 1964 Alaska earthquakes) and others which can occur around the Pacific Ocean "Ring of Fire."

In order to enhance the result from the 75- to 90-meter inundation grid data, a method was developed utilizing higher-resolution digital topographic data (3- to 10-meters resolution) that better defines the location of the maximum inundation line (U.S. Geological Survey, 1993; Intermap, 2003; NOAA, 2004). The location of the enhanced inundation line was determined by using digital imagery and terrain data on a GIS platform with consideration given to historic inundation information (Lander, et al., 1993). This information was verified, where possible, by field work coordinated with local county personnel.

The accuracy of the inundation line shown on these maps is subject to limitations in the accuracy and completeness of available terrain and tsunami source information, and the current understanding of tsunami generation and propagation phenomena as expressed in the models. Thus, although an attempt has been made to identify a credible upper bound to inundation at any location along the coastline, it remains possible that actual inundation could be greater in a major tsunami event.

This map does not represent inundation from a single scenario event. It was created by combining inundation results for an ensemble of source events affecting a given region (Table 1). For this reason, all of the inundation region in a particular area will not likely be inundated during a single tsunami event.

### References:

Intermap Technologies, Inc., 2003, Intermap product handbook and quick start guide: Intermap NEXTmap document on 5-meter resolution data, 112 p.

Lander, J.F., Lockridge, P.A., and Kozuch, M.J., 1993, Tsunamis Affecting the West Coast of the United States 1806-1992: National Geophysical Data Center Key to Geophysical Record Documentation No. 29, NOAA, NESDIS, NGDC, 242 p.

National Atmospheric and Oceanic Administration (NOAA), 2004, Interferometric Synthetic Aperture Radar (IFSAR) Digital Elevation Models from GeoSAR platform (EarthData): 3-meter resolution data.

Titov, V.V., and Gonzalez, F.I., 1997, Implementation and Testing of the Method of Tsunami Splitting (MOST): NOAA Technical Memorandum ERL PMEL – 112, 11 p.

Titov, V.V., and Synolakis, C.E., 1998, Numerical modeling of tidal wave runup: Journal of Waterways, Port, Coastal and Ocean Engineering, ASCE, 124 (4), pp 157-171.

U.S. Geological Survey, 1993, Digital Elevation Models: National Mapping Program, Technical Instructions, Data Users Guide 5, 48 p.

# TSUNAMI INUNDATION MAP FOR EMERGENCY PLANNING

State of California ~ County of San Diego

## OCEANSIDE QUADRANGLE SAN LUIS REY QUADRANGLE

June 1, 2009

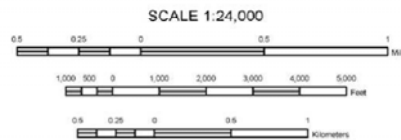

Table 1: Tsunami sources modeled for the San Diego County coastline.

Sources (M = moment magnitude used in modeled event)	Areas of Inundation Map Coverage and Sources Used		
	Dana Point	Oceanside	San Diego
Carlsbad Thrust Fault		X	X
Catalina Fault	X	X	X
Coronado Bank Fault			X
Lasuen Knoll Fault	X		X
San Clemente Fault Bend Region			X
San Clemente Island Fault			X
San Mateo Thrust Fault	X	X	
Coronado Canyon Landslide #1			X
Cascadia Subduction Zone #3 (M9.2)	X		X
Central Aleutians Subduction Zone#1 (M8.9)	X	X	X
Central Aleutians Subduction Zone#2 (M8.9)	X		X
Central Aleutians Subduction Zone#3 (M9.2)	X	X	X
Chile North Subduction Zone (M9.4)	X		X
1960 Chile Earthquake (M9.3)	X		X
1952 Kamchatka Earthquake (M9.0)	X		
1964 Alaska Earthquake (M9.2)	X	X	X
Japan Subduction Zone #2 (M8.8)	X		X
Kuril Islands Subduction Zone #2 (M8.8)	X		X
Kuril Islands Subduction Zone #3 (M8.8)	X		X
Kuril Islands Subduction Zone #4 (M8.8)	X		X



## MAP EXPLANATION

Tsunami Inundation Line

Tsunami Inundation Area

## PURPOSE OF THIS MAP

This tsunami inundation map was prepared to assist cities and counties in identifying their tsunami hazard. It is intended for local jurisdictional, coastal evacuation planning uses only. This map, and the information presented herein, is not a legal document and does not meet disclosure requirements for real estate transactions nor for any other regulatory purpose.

The inundation map has been compiled with best currently available scientific information. The inundation line represents the maximum considered tsunami runup from a number of extreme, yet realistic, tsunami sources. Tsunamis are rare events; due to a lack of known occurrences in the historical record, this map includes no information about the probability of any tsunami affecting any area within a specific period of time.

Please refer to the following websites for additional information on the construction and/or intended use of the tsunami inundation map:

State of California Emergency Management Agency, Earthquake and Tsunami Program: <http://www.oes.ca.gov/WebPage/oeswebsite.nsf/Content/B1EC51BA215931768825741F005E8D80?OpenDocument>

University of Southern California – Tsunami Research Center: <http://www.usc.edu/dept/tsunamis/2005/index.php>

State of California Geological Survey Tsunami Information: [http://www.conservation.ca.gov/cgs/geologic\\_hazards/Tsunami/index.htm](http://www.conservation.ca.gov/cgs/geologic_hazards/Tsunami/index.htm)

National Oceanic and Atmospheric Agency Center for Tsunami Research (MOST model): <http://nctr.pmel.noaa.gov/time/background/models.html>

## MAP BASE

Topographic base maps prepared by U.S. Geological Survey as part of the 7.5-minute Quadrangle Map Series (originally 1:24,000 scale). Tsunami inundation line boundaries may reflect updated digital orthophotographic and topographic data that can differ significantly from contours shown on the base map.

## DISCLAIMER

The California Emergency Management Agency (CalEMA), the University of Southern California (USC), and the California Geological Survey (CGS) make no representation or warranties regarding the accuracy of this inundation map nor the data from which the map was derived. Neither the State of California nor USC shall be liable under any circumstances for any direct, indirect, special, incidental or consequential damages with respect to any claim by any user or any third party on account of or arising from the use of this map.



TERRACOSTA CONSULTING GROUP  
ENGINEERS AND GEOLOGISTS  
3890 MURPHY CANYON ROAD, SUITE 200  
SAN DIEGO, CA 92123 (858) 573-6900

FIGURE NUMBER

12C

PROJECT NAME  
CITY OF CARLSBAD  
BEACH ACCESS REPAIRS

PROJECT NUMBER

3009

## TSUNAMI INUNDATION MAP LEGEND



**BASE MAP SOURCE:**

Adapted from a portion of "Landslide Hazards in the Northern Part of the San Diego Metropolitan Area, San Diego, California, Oceanside and San Luis Rey Quadrangles," (DMG OFR 95094-Plate 35A), 1995.



Scale:  
1"=2,000'

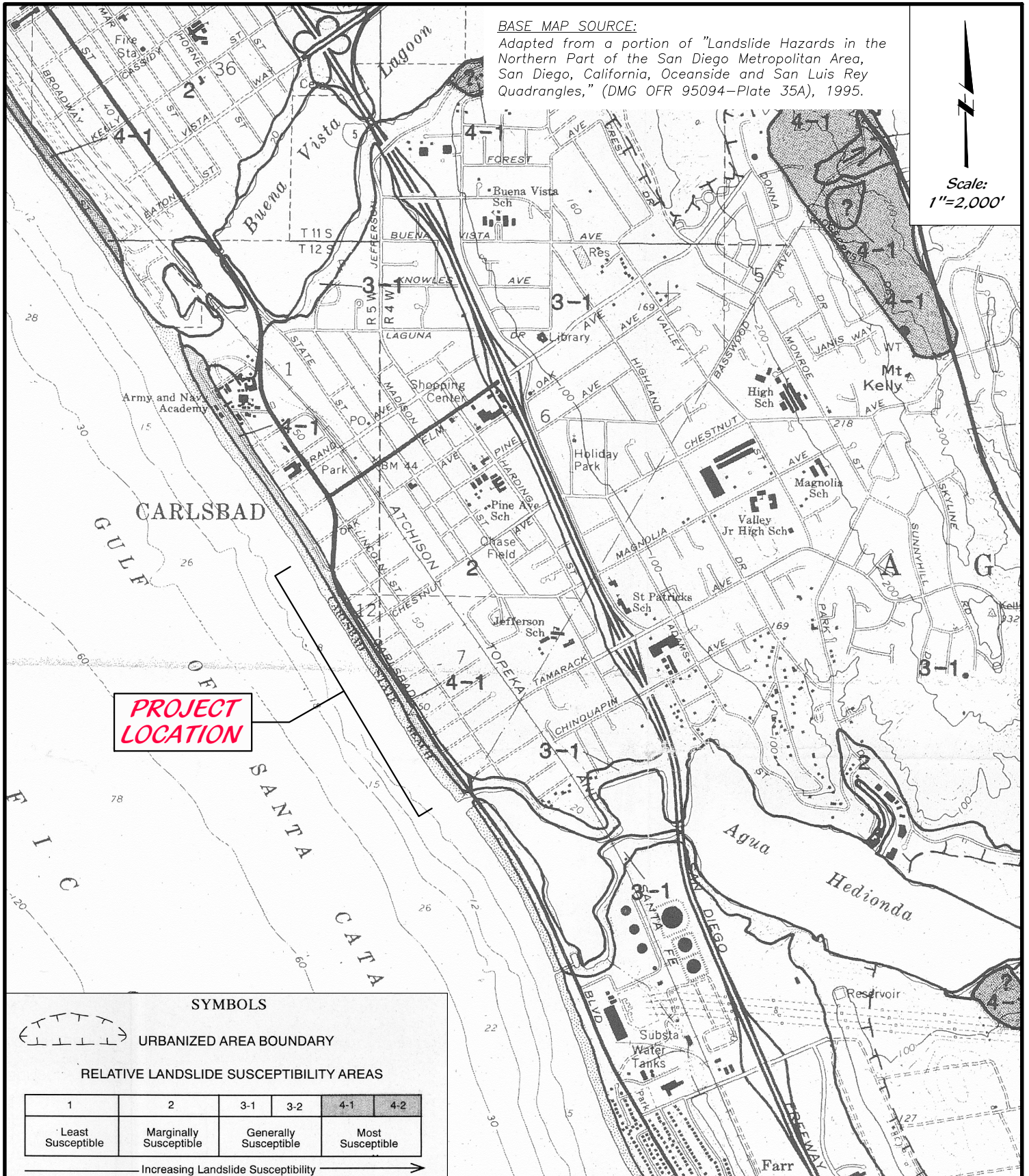

**PROJECT LOCATION**

**SYMBOLS**

URBANIZED AREA BOUNDARY

**RELATIVE LANDSLIDE SUSCEPTIBILITY AREAS**

1	2	3-1	3-2	4-1	4-2
Least Susceptible	Marginally Susceptible	Generally Susceptible		Most Susceptible	

Increasing Landslide Susceptibility →

**LANDSLIDES**



Landslide



Questionable Landslide



**TERRACOSTA CONSULTING GROUP**  
ENGINEERS AND GEOLOGISTS  
3890 MURPHY CANYON ROAD, SUITE 200  
SAN DIEGO, CA 92123 (858) 573-6900

PROJECT NAME  
**CITY OF CARLSBAD  
BEACH ACCESS REPAIRS**

FIGURE NUMBER

**13**

PROJECT NUMBER

**3009**

**LANDSLIDE DISTRIBUTION MAP**

# APPENDIX A

## PHOTOGRAPHS





**TERRACOSTA CONSULTING GROUP**  
 3890 Murphy Canyon Road, Suite 200  
 San Diego, California 92123 (858) 573-6900

PROJECT NO.:  
**3009**

PROJECT NAME:  
**CITY OF CARLSBAD  
 BEACH ACCESS REPAIRS**

TITLE:  
**ACCESS STAIRWAY NO. 1**

APPENDIX FIGURE NO.:  
**A-1a**





TOP LANDING  
NORTH SIDE  
(burrows)



TOP LANDING  
SOUTH SIDE  
(burrows)



**TERRACOSTA CONSULTING GROUP**  
3890 Murphy Canyon Road, Suite 200  
San Diego, California 92123 (858) 573-6900

PROJECT NO.:  
**3009**

PROJECT NAME:  
**CITY OF CARLSBAD  
BEACH ACCESS REPAIRS**

TITLE:  
**ACCESS STAIRWAY NO. 1**

APPENDIX FIGURE NO.:  
**A-1b**





**TERRACOSTA CONSULTING GROUP**  
 3890 Murphy Canyon Road, Suite 200  
 San Diego, California 92123 (858) 573-6900

PROJECT NO.:  
**3009**

PROJECT NAME:  
**CITY OF CARLSBAD  
 BEACH ACCESS REPAIRS**

TITLE:  
**ACCESS STAIRWAY NO. 2**

APPENDIX FIGURE NO.:  
**A-2a**





GULLY AND  
WET SOILS  
(Due to  
irrigation leak?)



**TERRACOSTA CONSULTING GROUP**  
3890 Murphy Canyon Road, Suite 200  
San Diego, California 92123 (858) 573-6900

PROJECT NO.:  
**3009**

PROJECT NAME:  
**CITY OF CARLSBAD  
BEACH ACCESS REPAIRS**

TITLE:  
**ACCESS STAIRWAY NO. 2**

APPENDIX FIGURE NO.:  
**A-2b**





NORTH SIDE  
(Old Stairway)



SOUTH SIDE  
(Old Stairway)



**TERRACOSTA CONSULTING GROUP**  
3890 Murphy Canyon Road, Suite 200  
San Diego, California 92123 (858) 573-6900

PROJECT NO.:  
**3009**

PROJECT NAME:  
**CITY OF CARLSBAD  
BEACH ACCESS REPAIRS**

TITLE:  
**ACCESS STAIRWAY NO. 2**

APPENDIX FIGURE NO.:  
**A-2c**





**TERRACOSTA CONSULTING GROUP**  
 3890 Murphy Canyon Road, Suite 200  
 San Diego, California 92123 (858) 573-6900

PROJECT NO.:  
**3009**

PROJECT NAME:  
**CITY OF CARLSBAD  
 BEACH ACCESS REPAIRS**

TITLE:  
**ACCESS STAIRWAY NO. 3**

APPENDIX FIGURE NO.:  
**A-3a**





**TERRACOSTA CONSULTING GROUP**  
 3890 Murphy Canyon Road, Suite 200  
 San Diego, California 92123 (858) 573-6900

PROJECT NO.:  
**3009**

PROJECT NAME:  
**CITY OF CARLSBAD  
 BEACH ACCESS REPAIRS**

TITLE:  
**ACCESS STAIRWAY NO. 3**

APPENDIX FIGURE NO.:  
**A-3b**





**TERRACOSTA CONSULTING GROUP**  
 3890 Murphy Canyon Road, Suite 200  
 San Diego, California 92123 (858) 573-6900

PROJECT NO.:  
**3009**

PROJECT NAME:  
**CITY OF CARLSBAD  
 BEACH ACCESS REPAIRS**

TITLE:  
**ACCESS STAIRWAY NO. 4**

APPENDIX FIGURE NO.:  
**A-4a**





**TERRACOSTA CONSULTING GROUP**  
 3890 Murphy Canyon Road, Suite 200  
 San Diego, California 92123 (858) 573-6900

PROJECT NO.:  
**3009**

PROJECT NAME:  
**CITY OF CARLSBAD  
 BEACH ACCESS REPAIRS**

TITLE:  
**ACCESS STAIRWAY NO. 4**

APPENDIX FIGURE NO.:  
**A-4b**





Note that soils have eroded away from foundation



**TERRACOSTA CONSULTING GROUP**  
 3890 Murphy Canyon Road, Suite 200  
 San Diego, California 92123 (858) 573-6900

PROJECT NO.:  
**3009**

PROJECT NAME:  
**CITY OF CARLSBAD  
 BEACH ACCESS REPAIRS**

TITLE:  
**ACCESS STAIRWAY NO. 5  
 AND SOUTHERN RESTROOM**

APPENDIX FIGURE NO.:  
**A-5a**





Almost 2-foot deep  
void under sidewalk



**TERRACOSTA CONSULTING GROUP**  
3890 Murphy Canyon Road, Suite 200  
San Diego, California 92123 (858) 573-6900

PROJECT NO.:  
**3009**

PROJECT NAME:  
**CITY OF CARLSBAD  
BEACH ACCESS REPAIRS**

TITLE:  
**ACCESS STAIRWAY NO. 5  
AND SOUTHERN RESTROOM**

APPENDIX FIGURE NO.:  
**A-5b**





NORTH SIDE  
(burrows)



SOUTH SIDE  
(burrows)



**TERRACOSTA CONSULTING GROUP**  
3890 Murphy Canyon Road, Suite 200  
San Diego, California 92123 (858) 573-6900

PROJECT NO.:  
**3009**

PROJECT NAME:  
**CITY OF CARLSBAD  
BEACH ACCESS REPAIRS**

TITLE:  
**ACCESS STAIRWAY NO. 6**

APPENDIX FIGURE NO.:  
**A-6**





Looking down at sidewalk foundation



**TERRACOSTA CONSULTING GROUP**  
3890 Murphy Canyon Road, Suite 200  
San Diego, California 92123 (858) 573-6900

PROJECT NO.:  
**3009**

PROJECT NAME:  
**CITY OF CARLSBAD  
BEACH ACCESS REPAIRS**

TITLE:  
**BLUFF-TOP WALKWAY  
PRECAST CONCRETE SECTIONS**

APPENDIX FIGURE NO.:  
**A-7**





**TERRACOSTA CONSULTING GROUP**  
 3890 Murphy Canyon Road, Suite 200  
 San Diego, California 92123 (858) 573-6900

PROJECT NO.:  
**3009**

PROJECT NAME:  
**CITY OF CARLSBAD  
 BEACH ACCESS REPAIRS**

TITLE:  
**BLUFF-TOP WALKWAY  
 SLAB-ON-GRADE CONCRETE SECTIONS**

APPENDIX FIGURE NO.:  
**A-8**





**TERRACOSTA CONSULTING GROUP**  
 3890 Murphy Canyon Road, Suite 200  
 San Diego, California 92123 (858) 573-6900

PROJECT NO.:  
**3009**

PROJECT NAME:  
**CITY OF CARLSBAD  
 BEACH ACCESS REPAIRS**

TITLE:  
**BLUFF-TOE WALKWAY AND CURB**

APPENDIX FIGURE NO.:  
**A-9a**





**TERRACOSTA CONSULTING GROUP**  
 3890 Murphy Canyon Road, Suite 200  
 San Diego, California 92123 (858) 573-6900

PROJECT NO.:  
**3009**

PROJECT NAME:  
**CITY OF CARLSBAD  
 BEACH ACCESS REPAIRS**

TITLE:  
**BLUFF-TOE WALKWAY  
 AND RETAINING WALL**

APPENDIX FIGURE NO.:  
**A-9b**



Ocean side of Seawall



Landward side of Seawall



**TERRACOSTA CONSULTING GROUP**  
 3890 Murphy Canyon Road, Suite 200  
 San Diego, California 92123 (858) 573-6900

PROJECT NO.:  
**3009**

PROJECT NAME:  
**CITY OF CARLSBAD  
 BEACH ACCESS REPAIRS**

TITLE:  
**CARLSBAD SEAWALL**

APPENDIX FIGURE NO.:  
**A-10**



APPENDIX B  
PREVIOUS GEOTECHNICAL REPORTS

3467 Kurtz Street  
San Diego, California 92110  
(619) 224-2911

# Woodward-Clyde Consultants

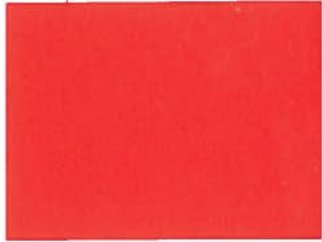

November 24, 1987  
Project No. 542681-DS09

City of Carlsbad  
2075 Las Palmas Drive  
Carlsbad, California 92009-4859

Attention: Pat Entezari  
Project Manager

## SUPPLEMENTAL GEOTECHNICAL DATA CARLSBAD BOULEVARD PROMENADE CARLSBAD, CALIFORNIA

Gentlemen:

In accordance with your request and the letter of Agreement for Engineering Services dated August 4, 1987, we have made additional studies of the geotechnical conditions along the alignment of the Carlsbad Boulevard Promenade between Cherry Avenue and Ocean Street in Carlsbad, California. The purpose of the studies is to document the existing conditions and to provide general geotechnical design criteria for the proposed sidewalk and viewing platforms.

As a part of this study, we have reviewed the Design Addendum for Carlsbad Boulevard Seawall dated July 25, 1986 and the Geological Investigation for the proposed Carlsbad Boulevard Seawall (included with the Contract Documents and Specifications for Carlsbad Seawall). Both of these documents were prepared by Woodward-Clyde Consultants. We have also made a visual reconnaissance of the Promenade alignment.

### PROJECT DESCRIPTION

The subject project will consist of approximately 1,964 feet of new concrete curb and gutter and reinforced concrete sidewalk. Approximately 1,001 feet of the walk will be precast concrete supported on 18-inch diameter drilled piers approximately 25 feet long and spaced at 34.5 feet on center. The remaining approximately 963 feet of walk will be supported on-grade. The walk will be approximately 10 feet - 4 inches wide and will have three viewing areas which will extend out an additional 8 feet and will be approximately 35 feet long. The viewing areas will be located at approximately Walnut Avenue, between Chestnut Avenue and Maple Avenue and at Acacia Avenue. The first two viewing areas will be precast concrete on piers and the last one will be cast-in-place concrete on-grade. The precast viewing area between Chestnut and Maple Avenues will also be a bus stop.

In addition to the walkway, there will be two new bluff access stairs. The stairs will be located near Maple Avenue and Hemlock Avenue. The stairway at Cherry Avenue will also be repaired. The existing guardrail along this portion of Carlsbad Boulevard will be removed and replaced with a new guardrail and several new storm drain inlets will be





installed with the new curb and gutter. New street and walkway lights will be installed from Ocean Street to Tamarack Avenue.

Typical profiles at selected locations along the alignment of the precast portion of the walk and the viewing areas are presented on the attached sheets. Approximate station locations of the profiles are 17+95, 18+80, 19+50, 20+73, 24+47, 25+60 and 26+34.

#### **SITE DESCRIPTION**

The subject project is located along the top of the bluff along the west side of Carlsbad Boulevard between Ocean Street at the north and Tamarack Avenue at the south. The existing elevations along the top of the bluff generally range from 48.5 feet at Cherry Avenue at 46.5 feet at Maple Avenue to 50 feet near Walnut Avenue down to 45 feet at Ocean Street. The top of the bluff along the west side of Carlsbad Boulevard from Ocean Street to approximately 100 feet south of Pine Avenue is relatively wide (10 to 20 feet) and flat. The flat portion of the top of the bluff narrows to the south of this area and the flat portion generally becomes 5 feet or less in width extending to the new stairway north of Sycamore Avenue. There are localized wider areas and gullies or eroded areas within this portion of the walkway alignment. The new Sycamore Avenue stairway and walk extend for approximately 85 feet. South of this area the top of the bluff is about 2 to 8 feet wide for a distance extending to about 200 feet south of Maple Avenue; where it widens to about 8 to 15 feet extending to the new proposed stairway north of Maple Avenue. South of the new proposed stairway, the bluff top widens to about 15 to 20 feet to Cherry Avenue. There is one large gully extending into this latter area located approximately 150 feet north of Cherry Avenue. The bluff slopes down from the upper level area to the seawall below at inclinations of approximately 1:1 to 2:1 (horizontal to vertical) and has an average height of approximately 30 feet.

#### **GENERAL SURFACE AND SUBSURFACE SOIL CONDITIONS**

##### Surface Soil Conditions

A visual reconnaissance of the surface soil conditions was made along the alignment of the upper bluff walkway between Ocean Street and Cherry Avenue. The results of the reconnaissance are summarized on the attached Table No. 1.

The area along the top of the bluff is generally covered by a thin layer (1 to 3 feet) of silty sand and gravel fill. Deep fills are located at Walnut Avenue (120 feet wide), Sycamore Avenue (20 feet wide), Maple Avenue (40 feet wide), south of Maple Avenue (100 feet wide), and south of Acacia Avenue (80 feet wide). The fills are generally underlain by the sandy terrace deposits.

##### Subsurface Soil Conditions

The subsurface soils as encountered in three test borings drilled along the top of the bluff for the seawall investigation and as observed in the exposures along the face of the bluff generally consist of approximately 2 to 5 feet of moderately compact moist, brown, silty sand fill underlain by terrace deposits composed of medium dense to very dense silty sand and poorly graded fine to medium sands. Within the terrace deposits locally thin cemented

zone and gravels up to 2 inches across were also observed. Below the terrace deposits, at approximately 7 to 15 feet above National Geodetic Vertical Datum (NGVD), the Santiago Formation was encountered. The Santiago Formation in the area is composed of indurated and well cemented sandstone.

The terrace materials generally consist of poorly graded fine to medium sands with approximately 5 to 10 percent fines (material passing a No. 200 sieve size). The dry density generally ranges from approximately 95 to 115 pcf with a mean value of 105 pcf with an average moisture content of 5 percent. The normalized sampler penetration values ranged from approximately 15 to over 60 blows per foot with a mean value of approximately 40 blows per foot. The mean friction angle for this material is approximately  $37^{\circ}$  with a standard deviation of approximately  $\pm 4-1/2^{\circ}$ .

The Santiago Formation materials generally consist of a cemented silty fine sand with about 15 to 25 percent fines. The average dry density and moisture content of a limited number of samples is approximately 122 pcf and 13 percent, respectively. The sampler penetration values were generally over 100 blows per foot and the unconfined compression values ranged from approximately 10,700 psf to 18,500 psf.

#### Ground Water

A perched ground water table typically occurs at the contact between the Santiago Formation and the Pleistocene deposits. This condition is common along the North County coastline and has been recognized as a contributing factor to bluff erosion. The ground water level generally ranges from about elevation +11 to +13 feet (NGVD) in the subject area.

The source of the ground water is thought to be primarily surface water introduced locally as rainfall and irrigation that percolates into the permeable terrace sands. When the ground water reaches the relatively impermeable Santiago Formation, it flow laterally along the seaward-sloping contact until it reaches the bluff face (the seawall in the subject area).

### CONCLUSIONS AND RECOMMENDATIONS

#### Slope Stability and Erosion

In general, the natural slopes comprising the coastal bluffs in the subject area appear to be grossly stable in their present condition. They have an average inclination on the order of 1-1/2:1 (horizontal to vertical) and are approximately 30 feet high. Stability analyses indicate that these slopes have a safety factor of approximately 1.5 against a deep seated slide for static conditions. Factors that could influence localized future shallow slope failure are heavy rainfall, human traffic and animal burrowing. It is our opinion that the proposed walkway, viewing areas and new stairways will help mitigate the erosive action of rainfall on the top of the bluff and human traffic down the bluff face. It is also our opinion that the new sidewalk and stairs should not significantly effect the stability of the bluffs.



It is recommended that all disturbed areas be repaired and hydroseeded after completion of construction. It is recommended that all walkways be sloped toward the street to provide positive drainage away from the top of the slope.

#### Concrete Sidewalk On-Grade

It is recommended that the subgrade for the upper bluff concrete sidewalk on-grade be properly prepared and compacted to a minimum relative compaction of 95 percent to a minimum depth of 12 inches. All other new fill or backfill should be compacted to a minimum relative compaction of 90 percent. Existing fill left in place should be tested and if less than 90 percent relative compaction, should be scarified to a minimum depth of 12 inches below existing grade or below the 12-inch subgrade and recompacted to a minimum relative compaction of 90 percent. It is not anticipated that any significant grading will be required on the on-grade portion of the proposed walk.

It is recommended that the outside edge of the on-grade walk extend a minimum depth of 12-inches below the lowest adjacent grade; deeper extensions may be required if the walk extends over the slope.

It is recommended that any retaining walls that are required for the on-grade sidewalk be designed for an equivalent lateral earth pressure of 30 pcf. All backfill materials should consist of select sand and the walls should be provided with adequate drainage to prevent the build-up of hydrostatic pressures.

#### Precast Concrete Walks and Viewing Platforms on Piers

It is anticipated that up to 2 feet of cut may be required in the precast concrete sections of the walk. This may result in 300 to 400 cubic yards of excavation. This material should be disposed of offsite, or used to prepare subgrade in the on-grade sidewalk areas, if required.

For precast concrete walkways, and view platforms supported on pier foundations, it is recommended that the piers be designed as friction piers. Friction values on the perimeter of the pier of 0 for the top 2 feet, 500 psf between a depth of 2 and 7 feet and 1,000 psf below 7 feet may be used for design. It is recommended that the piers have a minimum depth of 25 feet below the sidewalk surface and that they have a minimum diameter of 18 inches. It is estimated that the point of fixity for lateral loads will be at a depth of approximately 5 feet below the lowest adjacent ground surface.

It is our opinion that reducing the width of the walk from approximately 10-1/2 to 7-1/2 feet would not significantly change the length of the area where precast walk on piers is required, nor would it significantly reduce the volume of soil excavation. The only area that might be changed to on-grade sidewalk for the 7.5 feet width is between approximately Stations 25+77 to 26+87 (approximately 110 feet). The estimated excavation for the precast concrete walk in this area is about 40+50 cubic yards.

#### UNCERTAINTY AND LIMITATIONS

We have observed only a very small portion of the pertinent soil and groundwater conditions. The recommendations made herein are based on the assumption that soil

conditions do not deviate appreciably from those found during our field investigation. We recommend that Woodward-Clyde Consultants review the foundation and grading plans to verify that the intent of the recommendations presented herein has been properly interpreted and incorporated into the contract documents. We further recommend that Woodward-Clyde Consultants observe the site grading, subgrade preparation under concrete slabs and foundation excavations to verify that site conditions are as anticipated or to provide revised recommendations if necessary. If the plans for site development are changed, or if variations or undesirable geotechnical conditions are encountered during construction, we should be consulted for further recommendations.

This report is intended for design purposes only and may not be sufficient to prepare an accurate bid.

California, including San Diego, is an area of high seismic risk. It is generally considered economically unfeasible to build a totally earthquake-resistant project; it is, therefore, possible that a large or nearby earthquake could cause damage at the site.

Geotechnical engineering and the geologic sciences are characterized by uncertainty. Professional judgements presented herein are based partly on our understanding of the proposed construction, and partly on our general experience. Our engineering work and judgements rendered meet current professional standards; we do not guarantee the performance of the project in any respect.

Inspection services allow the testing of only a small percentage of the fill placed at the site. Contractual arrangements with the grading contractor should contain the provision that he is responsible for excavating, placing, and compacting fill in accordance with project specifications. Inspection by the geotechnical engineer during grading should not relieve the grading contractor of his primary responsibility to perform all work in accordance with the specifications.

This firm does not practice or consult in the field of safety engineering. We do not direct the contractor's operations, and we can not be responsible for the safety of personnel other than our own on the site; the safety of others is the responsibility of the contractor. The contractor should notify the owner if he considers any of the recommended actions presented herein to be unsafe.

If you have any questions or if we can be of further service, please call at your convenience.

Very truly yours,

WOODWARD-CLYDE CONSULTANTS

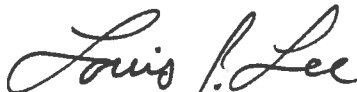

Louis J. Lee  
R.G.E. 502

Attachments



TABLE 1  
SURFACE SOIL DESCRIPTIONS  
UPPER BLUFF WALKWAY

<u>Location</u>	<u>Soil Description</u>
Pine Avenue to Walnut Avenue	Shallow (1 to 3 feet thick, gray-brown silty sand fill over terrace deposits, fill extends 20 to 30 feet down slope.
Walnut Avenue	Rebuilt fill slope approximately 120 feet wide (over storm drain) composed of silty sands and gravels, extending to toe of bluff; riprap toe protection.
Walnut Avenue to Sycamore Avenue	Shallow (1 to 3 feet thick) red-brown and gray-brown silty sand fill over terrace deposits, fill extends about 30 feet down slope; fill is deeper near Sycamore Avenue.
Sycamore Avenue	Deeper (greater than 3 feet thick) gray-brown silty sand fill approximately 20 feet wide (over storm drain) extends to toe of bluff.
Sycamore Avenue to 100 feet South of of Chestnut Avenue	Shallow (1 to 3 feet thick), gray brown silty sand fill extending 10 to 30 feet down slope; fill deeper and extends further down slope in localized areas.
100 feet South of Chestnut Avenue to to Maple Avenue	Exposed terrace deposits with localized thin (1 foot thick) cover of gray-brown sandy fill. Localized 2 to 5 feet thick gray-brown silty sand and gravel fill approximately 30 feet wide, extending to toe of bluff, located approximately 80 feet north of Maple Avenue.
Maple Avenue	Deep (greater than 5 feet thick) gray-brown silty sand and gravel fill (over storm drain); extends to toe of bluff and is approximately 40 feet wide.

TABLE 1  
 SURFACE SOIL DESCRIPTIONS  
 UPPER BLUFF WALKWAY

(Continued)

Location	Soil Description
Maple Avenue to 120 feet South	Gully or small canyon filled with dark brown silty sand fill with localized concrete rubble, asphalt and rocks; approximately 100 feet wide and extends to toe of bluff.
120 feet South of Maple Avenue to Acacia Avenue	Thin (1 to 3 feet thick) gray-brown silty sand and gravel fill; extends 10 to 15 feet down slope.
Acacia Avenue to 120 feet South	Upper slope covered with gray-brown to red-brown silty sand and gravel with cobbles fill; localized gully or small canyon fills composed of silty sand, gravel and concrete and asphalt debris extending 50 to 70 feet down slope; rebuilt fill slope south of Acacia Avenue composed of silty sands and gravels extending to toe of bluff, riprap toe protection.
120 feet South of Acacia Avenue to Cherry Avenue	Terrace deposits with localized thin (1 foot thick) cover of gray-brown silty sand fill; localized concrete rubble fill on slope north of Cherry Avenue.



APPENDIX B

GEOLOGICAL INVESTIGATION  
FOR THE PROPOSED CARLSBAD BOULEVARD SEAWALL  
CARLSBAD, CALIFORNIA

SOILS REPORT

APPENDIX B

GEOLOGICAL INVESTIGATION  
FOR THE PROPOSED CARLSBAD BOULEVARD SEAWALL  
CARLSBAD, CALIFORNIA

PURPOSE AND SCOPE OF INVESTIGATION

This report presents the results of the geotechnical investigation by Woodward-Clyde Consultants at the site of the proposed Carlsbad Boulevard Seawall. The site is located along Carlsbad Boulevard and Ocean Street Between Oak Avenue and the entrance to Agua Hedionda Lagoon in Carlsbad, California.

This report has been prepared for the City of Carlsbad for use in evaluating the property and in project design. This report presents Woodward-Clyde Consultants conclusions and/or recommendations regarding:

- The geologic setting of the site;
- Potential geologic hazards;
- General subsurface soil conditions;
- Ground water conditions within the depths of our subsurface investigation;
- Stability of proposed cut and fill slopes;
- Grading and earthwork;
- Types and depths of foundations;
- Allowable soil bearing pressures;

**BEST ORIGINAL**



- Settlements;
- Design pressures for retaining walls;
- Corrosivity and sulfate content of soil samples;

This report is included as a part of the Design Memorandum for the Carlsbad Boulevard Seawall.

#### DESCRIPTION OF THE PROJECT

For this study, we have discussed the project with City of Carlsbad staff and we have been provided with copies of the Feasibility Study prepared by Woodward-Clyde Consultants, dated November 1984 and the Draft Environmental Report prepared by Westec Services, Inc., dated March 1985. We have also been provided with a copy of portions of a report entitled "Coastal Storm Drain Study," prepared by Wilson Engineering, dated April 1984 and Sheets 8-11 of Drawing No. 159-9 for the Water System Improvements - Carlsbad Boulevard South, prepared by Engineering-Science, Inc., dated December 15, 1970.

We understand that the proposed project will include a seawall along the toe of the existing bluff, improvement of existing beach access ways, and the possible addition of one or more new stairways from the top of the bluff to the beach and new lateral access ways. The overall project extends along the beach for a distance of approximately 4,400 feet. Existing public beach access stairways, which lead down to the beach from the top of the bluff, are located at Tamarack Avenue at the south end and Cherry Avenue near the middle of the project. Existing vehicular beach access ramps are located at Tamarack Avenue at the south end and Pine Avenue at the north end of the project. A public restroom facility is located at Tamarack Avenue. Existing drain pipes are located upon the bluff at many locations. Many of the pipes lead down from storm drains and man-holes located along Carlsbad Boulevard and empty either on the

bluff or at the toe of the bluff. It is our understanding that these pipes are to be relocated and surface water runoff collected and diverted away from the bluffs. The location and general limits of the project are shown on the Site Plan (Figure No. 1 of the Design Memorandum).

#### FIELD AND LABORATORY INVESTIGATIONS

Our field investigation included making a visual geologic reconnaissance of the existing surface conditions, making beach profiles at approximate 200 foot intervals along the project alignment, obtaining disturbed samples of beach sand and cobbles, making three test borings on January 31, 1986, obtaining representative soil samples from and installing well points in each test boring. The test borings were advanced to depths ranging from 32½ to 43 feet. The drilling was performed, under the direction of a geologist from our firm, using an 8-inch diameter hollow stem auger truck mounted rig. The location of each test boring and the elevation of the ground surface at each location were estimated by reference to the Water System Improvement drawings dated December 15, 1970, as well as the new topographic information. The approximate locations of the test borings are shown on Figure No. 1 of the Design Memorandum.

A Key to Logs is presented on Figure B-1. Final logs of the test borings are presented as Figures B-2 through B-6. The descriptions on the logs are based on field logs, sample inspection, and laboratory test results.

Samples of the subsurface materials were obtained from the test borings using a modified California drive sampler (2-inch inside diameter and 2½-inch outside diameter) with thin brass liners. The sampler was generally driven 18 inches into the material at the bottom of the hole by a 140-pound hammer falling 30 inches; thin metal liner tubes containing the sample were removed from the sampler, sealed to preserve the natural moisture content of the sample, and returned to the laboratory for examination and testing.



The materials observed in the test borings were visually classified and evaluated with respect to strength, swelling, and compressibility characteristics; dry density; and moisture content. The classifications were substantiated by performing grain size analyses on representative samples of the soils. Fill suitability tests, including compaction tests and direct shear tests, were performed on samples of the probable fill soils.

The strength of the soils was evaluated by performing unconfined compression tests and direct shear tests on selected samples, and by considering the density and moisture content of the samples and the penetration resistance of the sampler. Results of the laboratory tests on drive samples are shown with sampler penetration resistance at the corresponding sample locations on the logs and on Figures B-7 through B-16. Fill suitability tests are presented on Figure B-17. The results of pH, resistivity and water soluble sulfates tests are included as an attachment from Clarkson Laboratory and Supply, Inc. Grain size distribution curves for the beach sands are presented on Figure B-10.

The well installations generally consisted of an approximate 4'-9" long well screen placed near the bottom of the test boring and surrounded with No. 20 sand. A solid riser pipe was extended to the surface and the hole backfilled with native soil. A locked cap was installed and the riser pipe concreted-in at the top.

## GENERAL SITE CONDITIONS

### Geologic Setting

The shoreline along Carlsbad Beach State Park, like much of the coastline along San Diego County, is backed by low coastal bluffs. The bluffs are backed by a broad, low relief coastal plain that generally extends several tens of miles inland. Agua Hedionda Lagoon and Buena Vista Lagoon are two lagoons located immediately south and about  $\frac{1}{2}$  mile north, respectively, of Carlsbad State Beach. The lagoons generally act as "sediment traps",

as sand and sediment are largely discharged from the lagoons only during periods of sustained, high runoff. Longshore transport of sand in the littoral zone along this stretch of coastline is predominantly to the south. In order to maintain circulation and tidal action within Agua Hedionda Lagoon, the entrance to the lagoon is periodically dredged. The sediment dredged from the lagoon is distributed hydraulically along the beach area south of the lagoon inlet.

#### Geologic Units and Erosion Characteristics

The coastal bluffs backing the state beach area are underlain by Eocene sandstone of the Santiago Formation; the sandstone is typically exposed as a low ledge along portions of the toe of the coastal bluff. The Santiago Formation is overlain by Pleistocene terrace deposits which are exposed along the face of the bluffs. The Pleistocene sediments were deposited upon a wave-cut platform (marine terrace) that was cut during a high stand of sea level estimated at about 85,000 to 120,000 years ago. The contact between the two geologic units generally varies in elevation along the toe of the bluff from +6 to +12 feet and dips down to as low as -4 feet at the south end of the study area.

The Santiago Formation consists of greenish grey clayey sandstone; the sediment comprising this formation is indurated and is generally much more resistant to erosion than the Pleistocene sand. The upper bluffs are comprised of friable, fine- to coarse-grained sand. These deposits are typically weakly cemented, and are not capable of standing for long periods as vertical exposures over several feet in height. Steep faces eroded into the Pleistocene deposits are only marginally stable, and quickly slough back to a less steep slope inclination. The Pleistocene deposits are also relatively easily eroded by surface water runoff. Many relatively deep gullies and small ravines have been partially filled with material dumped from the bluff top.



### Geologic Structure

Local bedding attitudes within the Santiago Formation could not be determined from the current exposures. The regional dip of the Santiago Formation is generally to the northeast at inclinations typically less than 10 degrees. Bedding within the Pleistocene deposits is nearly horizontal; the lower sandy portion is highly cross-bedded. The contact between the two geologic units locally slopes seaward at several degrees.

The presence of fractures, joints or faults may greatly accelerate the wave erosion process in the coastal environment. The Pleistocene terrace deposits are generally not a highly fractured or jointed unit; no faults were observed, nor have any faults been mapped that displace the marine terrace. The Santiago Formation, however, is typically jointed and fractured to varying degrees; many northeast-trending fractures and small faults commonly cut the Eocene bedrock. At other nearby locations along the coast, such features as surge channels and sea caves are commonly formed by wave action scouring the sedimentary rock adjacent to faults or fractures. Along the study area, bluff erosion does not appear to be greatly influenced by these features.

### Seismicity and Faulting

The faults within the study area do not displace the wave-cut terrace and are overlain by Pleistocene deposits, indicating that movement has not occurred during the past at least 85,000 and possibly 120,000 years.

The nearest potential earthquake sources is the offshore continuation of the Rose Canyon Fault zone, mapped about 3 miles west of the study area. More distant earthquake sources include the Elsinore Fault zone, mapped about 25 miles to the northeast, and the Coronado Banks Fault zone, approximately 20 miles to the west. Many historic moderate earthquakes have occurred on the Elsinore Fault, whereas no earthquakes of magnitude greater than 4.0 have been recorded on the Rose Canyon. In general,

although the historic seismicity record of Southern California is relatively short, the San Diego area has historically been recognized as an area of relatively low seismic activity. Although no specific seismic evaluation was performed for this study it appears to be reasonable to estimate that the largest earthquake-induced ground acceleration at the site with an average recurrence of 50 years is about 0.15g.

#### Landslides

No existing landslides were observed on the site during our investigation, nor were any noted on published geologic maps used for our study. The terrace sands are subject to sloughing and blockfalls where the bluff has been undercut by wave action or human digging. Numerous burrows have also been dug into the bluffs by ground squirrels. These erosion processes result in mass wasting deposits which occur along the coastal bluff on slopes of the Pleistocene terrace unit. These deposits are usually composed of unsorted mixtures of locally derived materials and generally range from a few inches to several feet in thickness. Deposits formed by mass wasting accumulate on the upper beach at the toe of the bluff and are subsequently eroded and disposed by wave action and littoral drift.

#### Surface Conditions

North of Agua Hedionda Lagoon, Carlsbad Boulevard extends generally parallel to and along the top of the bluff above Carlsbad State Beach. The boulevard is generally set back from the bluff edge distances varying between as little as 2 feet to as much as 50 feet. Public parking is available along the west side of Carlsbad Avenue between Tamarack and Cherry Avenue. At the intersection of Pine Avenue, Carlsbad Boulevard turns inland away from the coastal bluffs. At this point, Ocean Street continues northerly adjacent to the bluff top. Parking is also available along the west side of Ocean Street. Private homes have been built along the bluff north of Oak Avenue.



At the south end of the study area, two parallel rock jetties extend seaward about 200 feet from the mouth of Agua Hedionda Lagoon. A paved public parking area is located north of the jetties and generally south of Tamarack Avenue. The parking area includes approximately 2 acres and is located generally west of and below Carlsbad Boulevard along the toe of the bluff. Grading for the parking area apparently consisted of placing fill from the back beach area, adjacent to the toe of the bluff, out to near the end of the jetties. This resulted in a relatively level pad several feet above the elevation of the beach. A new concrete block wall has been constructed along the toe of the bluff (east side of parking lot) and some rock riprap has been placed along the seaward (west) limits of the parking area as a means of temporary slope protection. The riprap generally consists of a single layer of 2 to 4 ton stone placed upon a cobble berm.

-A local park area, which extends along a portion of the top of the bluffs, consists of a landscaped picnic area with a concrete walkway leading generally through the picnic area and along the top of the bluff. This park extends from south of Tamarack Avenue north to approximately Cherry Avenue. The landscaping includes trees, grassy area, picnic tables and a low wooden railing along the top of the bluff. A public restroom is located near the top of the bluff near Tamarack Avenue. Public beach access stairways, which lead down from the top of the bluff, are located at the restroom facility (Tamarack Avenue) and across from Cherry Avenue. A vehicular beach access ramp is also located near the north end of the park at Ocean Street. Beach access is also available at the parking lot at the south end of the park. The public access at Cherry Avenue consists of a stairway elevated several feet above the bluff by columns and pier foundations. The stairway was originally located adjacent to a second public restroom located at beach level. During the winter storms of 1983, this restroom, and the lower stairway landing were heavily damaged by storm waves and were subsequently demolished and removed. Portions of the concrete-slab foundations below the old restroom area remain in place on the beach. The lower stairway landing has been

repaired and the stairs replaced with a wooden structure. A portion of the natural slope below the upper landing has been rebuilt with stacked sand-filled sacks.

Drain pipes are located upon the bluff at many locations. Several of the pipes lead down from storm drains and man-holes located along Carlsbad Boulevard to concrete box culverts built at the toe of the bluff. Other pipes collect surface water run off from along Carlsbad Boulevard and adjacent areas.

Gullies and deep ravines are developed nearly continuously along the face of the bluff. Many of the wider, more extensively gullied areas extend from the beach level up to the top of the bluff. The upper portions of many of the deeper gullies and ravines have been partially filled with material dumped from the top of the bluff. The materials used for the dumped fill include concrete and asphalt rubble.

Two areas of the upper bluff adjacent to Carlsbad Avenue have required fairly extensive temporary slope repair. This slope rebuilding was required in 1983 along two approximately 50 foot wide stretches of the bluffs west of Walnut Avenue and Acacia Avenue. This temporary slope repair generally consisted of rebuilding the slope by placing a fill slope down to the level of the beach, and using riprap to protect the toe of the fill slope. Jute netting was laid upon the slope to retard surface water erosion.

Much of the bluff face is barren; vegetation along the bluff consists of scattered patches of iceplant and native grasses with locally dense stands of bamboo.

The beach along the base of the bluffs is typically about 100 to 150 feet wide. Abundant cobbles form a low berm several tens of feet wide along the back edge of the beach. Seasonal variations in longshore drift, wave height and wave frequency result in varying beach levels and volumes of sand.



### Subsurface Soil Conditions

The subsurface soils as encountered in the three borings drilled along the top of the bluff and as observed in the exposures along the face of the bluff generally consist of approximately 2 to 5 feet of moderately compact moist, brown, silty sand fill underlain by terrace deposits composed of medium dense to very dense silty sand and poorly graded fine to medium sands. Within the terrace deposits locally thin cemented zone and gravels up to 2 inches across were also observed. Below the terrace deposits, at approximately 7 to 15 feet above **National Geodetical Vertical Datum (NGVD)**, the Santiago Formation was encountered. The Santiago Formation in the area is composed of indurated and well cemented sandstone.

The beach at Carlsbad State Beach has a moderately varying terrain consisting of clean fine beach sands, non-uniformly dispersed cobbles, boulders, and exposed bedrock. From the toe of the bluffs extending seaward, the surficial geology is basically exposed cobbles and boulders on an elevated beach terrace followed by a descending slope covered with additional cobbles thinning toward sparse cobbles and gravels embedded in clean beach sand. The cobbles range in size from approximately 3 to 8 inches. This is followed by a gentle sloping surf zone of clean graded, fine beach sands. During the winter the beach material generally appears to have a thickness of 2 to 6 feet with localized thicker areas. At approximately 150 to 200 feet and beyond, projecting bedrock is exposed in the surf zone.

### Soil Characteristics

The terrace materials generally consist of poorly graded fine to medium sands with approximately 5 to 10 percent fines (material passing a No. 200 sieve size). The dry density generally ranges from approximately 95 to 115 pcf with a mean value of 105 pcf with an average moisture content of 5 percent. The normalized sampler penetration values ranged from approxi-

mately 15 to over 60 blows per foot with a mean value of approximately 40 blows per foot. The mean friction angle for this material is approximately  $37^\circ$  with a standard deviation of approximately  $\pm 4\frac{1}{2}^\circ$ .

The Santiago Formation materials generally consist of a cemented silty fine sand with about 15 to 25 percent fines. The average dry density and moisture content of a limited number of samples is approximately 122 pcf and 13 percent, respectively. The sampler penetration values were generally over 100 blows per foot and the unconfined compression values ranged from approximately 10,700 psf to 18,500 psf.

The beach materials at the time of our study generally consisted of clean fine sands with rounded and elongated gravel and cobble. The beach sands typically have a 100 percent material finer than a No. 30 sieve size (0.59 mm) and zero percent finer than a No. 200 sieve size (0.074 mm). The gravel and cobbles generally range from approximate 1 to 8 inches in average diameter. The gravel and cobble are generally higher on the beach and decrease in size as you move out from the toe of the bluff.

#### Ground Water

A perched ground water table typically occurs at the contact between the Santiago Formation and the Pleistocene deposits. This condition is common along the North County coastline and has been recognized as a contributing factor to bluff erosion.

The source of the ground water is thought to be primarily surface water introduced locally as rainfall and irrigation that percolates into the permeable terrace sands. When the ground water reaches the relatively impermeable Santiago Formation, it flows laterally along the seaward-sloping contact until it reaches the bluff face. A line of vegetation commonly grows at this point on the bluff. Prominent ground water seepage was observed along the toe of the bluffs at many locations within the study area.



Ground water was encountered in each test boring and was observed seeping out at the toe of the bluff along the contact between the terrace sands and sandstone formations. Periodic water elevation measurements made in the test boring wells are presented below:

<u>Date</u>	<u>Test Boring 1 (Tamarack Ave.)</u>	<u>Test Boring 2 (Cherry Ave.)</u>	<u>Test Boring 3 (Pine Ave.)</u>
01-31-86	+11.5	+12.5	+11.0
02-06-86	+12.1	+12.7	+11.6
02-21-86	+12.3	+12.9	+11.8
03-03-86	+12.2	+12.8	+11.7
03-12-86	+12.3	+13.0	+11.8
03-20-86	+12.3	+13.0	+11.8

\* Elevations are **NGVD**

It should be anticipated that minor variations will occur in the ground water levels, depending on the amount of rain fall and land irrigation in the area.

#### DISCUSSIONS, CONCLUSIONS, AND RECOMMENDATIONS

The discussions, conclusions, and recommendations presented in this report are based on the information provided to us, results of our field and laboratory studies, analyses, and professional judgment.

#### Potential Geologic Hazards

##### Faulting and Ground Shaking

No active faults were identified on the site and the closest active fault zones are the Elsinore Fault approximately 25 miles from the site and the

Coronado Banks Fault approximately 20 miles from the site. No detailed seismic evaluation of the site has been made; however, it is recommended that a **minimum ground acceleration of 0.15g** be used for design of the seawall.

#### Liquefaction

The terrace sands are generally dense to very dense and the sandstone is very dense and cemented. The water table is generally confined to a thin zone (5 to 10 feet thick) above the contact between the two formations. It is our opinion that there is a **low probability of liquefaction** occurring in these materials at the subject site.

#### Site Grading

##### Excavation and Material Characteristics

It is anticipated that some cutting and filling will be required to construct the proposed seawall and associated facilities. The terrace sand are relatively friable and should be relatively easy to excavate. These materials should also provide a suitable select granular fill. The sandstone of the Santiago Formation are relatively hard and cemented and may require special equipment to excavate; however it is not anticipated that any blasting will be required. Excavation of the sandstone may also result in some oversize material that may require crushing or breaking up for use in fills.

#### Temporary Cut Slopes

Our analyses indicate that temporary cuts in the undisturbed terrace sands should have a safety factor of 1.2 or greater against a deep slide for inclinations of 1:1 or flatter up to approximately 20 feet in height. It is anticipated that the sandstone should stand at near vertical inclinations of up to 10 feet in height. These materials are subject to localized sloughing



and blockfalls and should be observed during construction. Special treatment, shoring or flattening of slopes may be required in some areas.

#### Natural Slopes

In general, the natural slopes comprising the coastal bluffs appear to be grossly stable in their present condition. However, the sandy, friable terrace deposits, when undercut and oversteepened by wave action, are only marginally stable at relatively steep slope inclinations. Experience with this geologic unit in the subject area and at other locations along the coast has shown that once slopes are oversteepened, additional surface sloughing and/or relatively shallow slope failures are likely to continue to occur within and adjacent to the undercut area until more stable slope inclinations are reached. Factors that could influence slope failures within such potentially unstable areas include heavy rainfall, ground water seepage, earthquakes, and additional erosion by high wave action. Relatively minor slope failures or blockfalls could represent a potential hazard to beach users.

#### Cut and Fill Slopes

We have performed stability analyses for anticipated cut and fill slopes by the Jaubu method using the following strength parameters for the terrace materials:  $\phi = 37^\circ$ ,  $C = 100$  psf. The results of the analyses indicate that the slopes with maximum inclinations of  $1\frac{1}{2}:1$  (horizontal to vertical) and maximum heights of 30 feet have calculated factors of safety in excess of 1.5 for static conditions, and in excess of 1.2 for dynamic conditions, assuming a horizontal coefficient of ground acceleration of 0.15g. Stability analyses require using parameters selected from a range of possible values. There is a finite possibility that slopes having calculated factors of safety, as indicated, could become unstable. In our opinion, the probability of slopes becoming unstable under the assumed conditions is low.

Fill slopes, especially those constructed at inclinations steeper than 2:1, are particularly susceptible to shallow slope sloughing in periods of rainfall, heavy irrigation, and/or upslope surface runoff. Periodic slope maintenance may be required, including rebuilding the outer  $1\frac{1}{2}$  to 4 feet of the slope. Sloughing of fill slopes can be reduced by overbuilding at least 3 feet and cutting back to the desired slope. To a lesser extent, sloughing can be reduced by backrolling slopes at frequent intervals. As a minimum, we recommend that fill slopes be trackwalked so that a dozer track covers the surfaces at least twice. We recommend that cut and fill slopes be planted, drained, and maintained.

#### Fill Compaction

It is recommended that structural fills be compacted to a minimum relative compaction of 92 percent in accordance with ASTM Test Designation -1557-78. Structural fills should be observed and tested by the geotechnical engineer.

#### Drainage

A perched ground water table is present along the contact between the terrace sands and underlying sandstone which results in water seepage at the toe of the bluff. It is recommended that all retaining structures be provided with back drains to intercept and control this seepage. It is further recommended that the back drain be placed at an elevation of approximately +10 to +12 feet (NGVD) behind the proposed seawall.

It is also recommended that existing drains on the bluff generally be abandoned and that a new storm drain system be designed and constructed to collect and divert runoff away from the bluff. The new facilities should be designed such that surface drainage waters are directed away from the bluff top.



The site is located along the edge of the Pacific Ocean and is subject to inundation from tides and the action of waves. The contractor will have to take special measures to protect his work and to keep construction areas free from surface, subsurface and ocean water.

### Foundations

It is recommended that the foundations for the seawall and beach access stairways be founded in the dense sandstone of the Santiago formations. The foundations should have a minimum width of 2 feet and extend a minimum of 2 feet into the sandstone. Where foundations are exposed to scour from wave action, the foundations should either be protected by toe stone or extend below the design scour depth.

It is recommended that for foundations bearing in sandstone, a maximum allowable soil bearing pressure of 8,000 psf be used for design. This value may be increased by up to one third for loads that include wind or seismic forces. All loose or disturbed material should be cleaned from foundation excavations and foundations should bear on clean undisturbed sandstone.

It is estimated that settlements under anticipated loads will be less than  $\frac{1}{2}$  inch.

### Retaining Walls

It is anticipated that the seawall may be designed as a cantilever retaining structure along the toe of the existing bluff. Two possible conditions are considered, one with a level backfill and walkway behind the wall and one with an average slope inclination of approximately  $1\frac{1}{2}$ :1 (horizontal to vertical) and no walkway behind the wall. For these conditions, it is recommended that the following equivalent fluid lateral earth pressures be used for design:

Level Backfill - 30 pcf (Static)  
15 pcf (Seismic-inverted)

1½:1 Slope - 60 pcf (Static)  
30 pcf (Seismic-inverted)

It is further recommended that an average total unit weight and submerged unit weight of 115 and 55 pcf be used for the backfill and terrace sands.

It is recommended that the retaining walls be provided with a back drain to limit the ground water level to elevation +10 to +12 feet (NGVD). Water pressures should be considered to act on the wall below this elevation.

To resist lateral pressures, it is recommended that for foundations in the sandstone a uniform passive pressure of 2,000 psf and a friction coefficient of 0.3 be used for design.

UNCERTAINTY AND LIMITATIONS

*may be combined  
per L Lee 11/15/86*

We have observed only a very small portion of the pertinent soil and ground water conditions. The recommendations made herein are based on the assumption that soil conditions do not deviate appreciably from those found during our field investigation. We recommend that Woodward-Clyde Consultants observe the site grading and foundation excavations to verify that site conditions are as anticipated or to provide revised recommendations if necessary. If variations or undesirable geotechnical conditions are encountered during construction, we should be consulted for further recommendations.

This report is intended for design purposes only and may not be sufficient to prepare an accurate bid.

California, including San Diego, is an area of high seismic risk. It is generally considered economically unfeasible to build a totally earthquake-resistant project; it is, therefore, possible that a large or nearby earthquake could cause damage at the site.

Geotechnical engineering and the geologic sciences are characterized by uncertainty. Professional judgements presented herein are based partly on our understanding of the proposed construction, and partly on our general experience. Our engineering work and judgements rendered meet current professional standards; we do not guarantee the performance of the project in any respect.

Inspection services allow the testing of only a small percentage of the fill placed at the site. Contractual arrangements with the grading contractor should contain the provision that he is responsible for excavating, placing, and compacting fill in accordance with project specifications. Inspection by the geotechnical engineer during grading should not relieve the grading contractor of his primary responsibility to perform all work in accordance with the specifications.

This firm does not practice or consult in the field of safety engineering. We do not direct the contractor's operations, and we can not be responsible for the safety of personnel other than our own on the site; the safety of others is the responsibility of the contractor. The contractor should notify the owner if he considers any of the recommended actions presented herein to be unsafe.



Location

Boring Number

Elevation

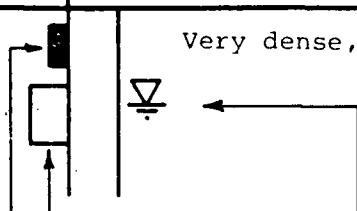
DEPTH IN FEET	TEST DATA			OTHER TESTS	SAMPLE NUMBER	SOIL DESCRIPTION
	*MC	*DD	*BC			
12	110	65			1	Very dense, damp, brown silty sand (SM)    WATER LEVEL At time of drilling or as indicated.  SOIL CLASSIFICATION Soil Classifications are based on the Unified Soil Classification System and include color, moisture and consistency. Field descriptions have been modified to reflect results of laboratory analyses where appropriate.  DISTURBED SAMPLE LOCATION Obtained by collecting the auger cuttings in a plastic or cloth bag.  DRIVE SAMPLE LOCATION MODIFIED CALIFORNIA SAMPLER Sample with recorded blows per foot was obtained with a Modified California drive sampler (2" inside diameter, 2.5" outside diameter) lined with sample tubes. The sampler was driven into the soil at the bottom of the hole with a 140 pound hammer falling 30 inches.  STANDARD PENETRATION SAMPLER (*) Sample with recorded blows per foot was obtained using a standard split spoon sampler (1 3/8" inside diameter, 2" outside diameter). The sampler was driven into the soil at the bottom of the hole with a 140 pound hammer falling 30 inches and the sample placed in a plastic bag.  INDICATES SAMPLE TESTED FOR OTHER PROPERTIES GS - Grain Size Distribution      CT - Consolidation Test LC - Laboratory Compaction Test      UCS - Unconfined Compression Test PI - Atterberg Limits Test      SDS - Slow Direct Shear Test ST - Loaded Swell Test      DS - Direct Shear Test CC - Confined Compression Test      TX - Triaxial Compression Test 'R' - R-Value SG - Specific Gravity NOTE: In this column the results of these tests may be recorded where applicable.  BLOW COUNT Number of blows needed to advance sampler one foot or as indicated.  DRY DENSITY Pounds per Cubic Foot      See Note 2.  MOISTURE CONTENT Percent of Dry Weight

**NOTES ON FIELD INVESTIGATION**

1. REFUSAL indicates the inability to extend excavation, practically, with equipment being used in the investigation.
2. Blow counts for Standard Penetration Test are indicated by an asterisk (\*), all other blow counts are for the Modified California Sampler.

<b>KEY TO LOGS</b> CARLSBAD BOULEVARD SEAWALL			
DRAWN BY: ch	CHECKED BY:	PROJECT NO: 542681-SIO1	DATE: 3-6-86
			FIGURE NO: B-1

Boring 1

Approximate El. 35'

DEPTH IN FEET	TEST DATA			*OTHER TESTS	SAMPLE NUMBER	SOIL DESCRIPTION
	*MC	*DD	*BC			
					1-1	Moist, brown, silty sand FILL
7	103	5	GS		1-2	
5					1-3	Medium dense, damp, brown, silty sand (SM) TERRACE DEPOSITS
3	95	29	GS, SDS		1-4	----- Grading to ----- Medium dense to very dense, damp, light brown, poorly graded fine to medium sand (SP) TERRACE DEPOSITS
10					1-5	
2	132	36	GS		1-6	Grades to pale brown to pale gray color
15					1-7	
2	101	65	GS		1-8	
20					1-9	
		65/6"			1-10	Very dense, moist, gray, silty fine sand (SM) with local thin cemented zones SANTIAGO FORMATION Water at 23½' after well installation
25					1-11	
		86/6"			1-12	
14	121	56/6"	GS, PI UCS=10671 psf		1-13	Bottom of Hole
35						
40						

\*For description of symbols, see Figure B-1.

LOG OF TEST BORING 1  
CARLSBAD BOULEVARD SEAWALL

DRAWN BY: ch

CHECKED BY:

PROJECT NO: 542681-SIO1

DATE: 3-6-86

FIGURE NO: B-2

DEPTH IN FEET	TEST DATA			*OTHER TESTS	SAMPLE NUMBER	SOIL DESCRIPTION
	*MC	*DD	*BC			
					2-1	Moist, brown, silty sand FILL
			10		2-2	Medium dense, moist, light brown to reddish brown, silty to fine sand (SM-SP) TERRACE DEPOSITS
5					2-3	Medium dense, moist, light brown, fine to medium sand (SP) TERRACE DEPOSITS
			21		2-4	
10					2-5	Dense, moist, pale brown, fine sand (SP) with some black particles TERRACE DEPOSITS
6	99	31	GS		2-5	
15			LC, SDS		2-6	
5	110	44	SDS SG= 2.80		2-7	Medium dense to dense, moist, light brown to gray, medium to fine sand (SP) TERRACE DEPOSITS
20					2-8	
			17		2-8	
25					2-9	
3	97	60	GS, SDS		2-9	
30					2-10	Dense, moist, pale brown, gravelly to poorly sand (SP-GP) gravels up to 2" maximum dimension TERRACE DEPOSITS
			50/ 5 1/2"		2-10	
35						Water table at 34 1/2' after well installation
			75/ 6"		2-11	Very dense, moist, gray, silty fine sand (SM) (sandstone) SANTIAGO FORMATION
40						

\*For description of symbols, see Figure B-1

Continued on next page

LOG OF TEST BORING 2 CARLSBAD BOULEVARD SEAWALL			
DRAWN BY: ch	CHECKED BY:	PROJECT NO: 542681-SIO1	DATE: 3-6-86
		FIGURE NO: B-3	



Boring 2 (Cont'd)

DEPTH IN FEET	TEST DATA			*OTHER TESTS	SAMPLE NUMBER	SOIL DESCRIPTION
	*MC	*DD	*BC			
13	122	56/ 6"	GS, PI UCS= 17965 psf SG= 2.68	2-12		(Continued) very dense, moist, gray, silty fine sand (SM) (sandstone)! SANTIAGO FORMATION
45						Bottom of Hole
50						
55						
60						
65						
70						
75						
80						

\*For description of symbols, see Figure B-1

LOG OF TEST BORING 1 (CONT'D) CARLSBAD BOULEVARD SEAWALL				
DRAWN BY: ch	CHECKED BY:	PROJECT NO: 542681-SIO1	DATE: 3-6-86	FIGURE NO: B-4

Boring 3

Approx. Gate El. 43'

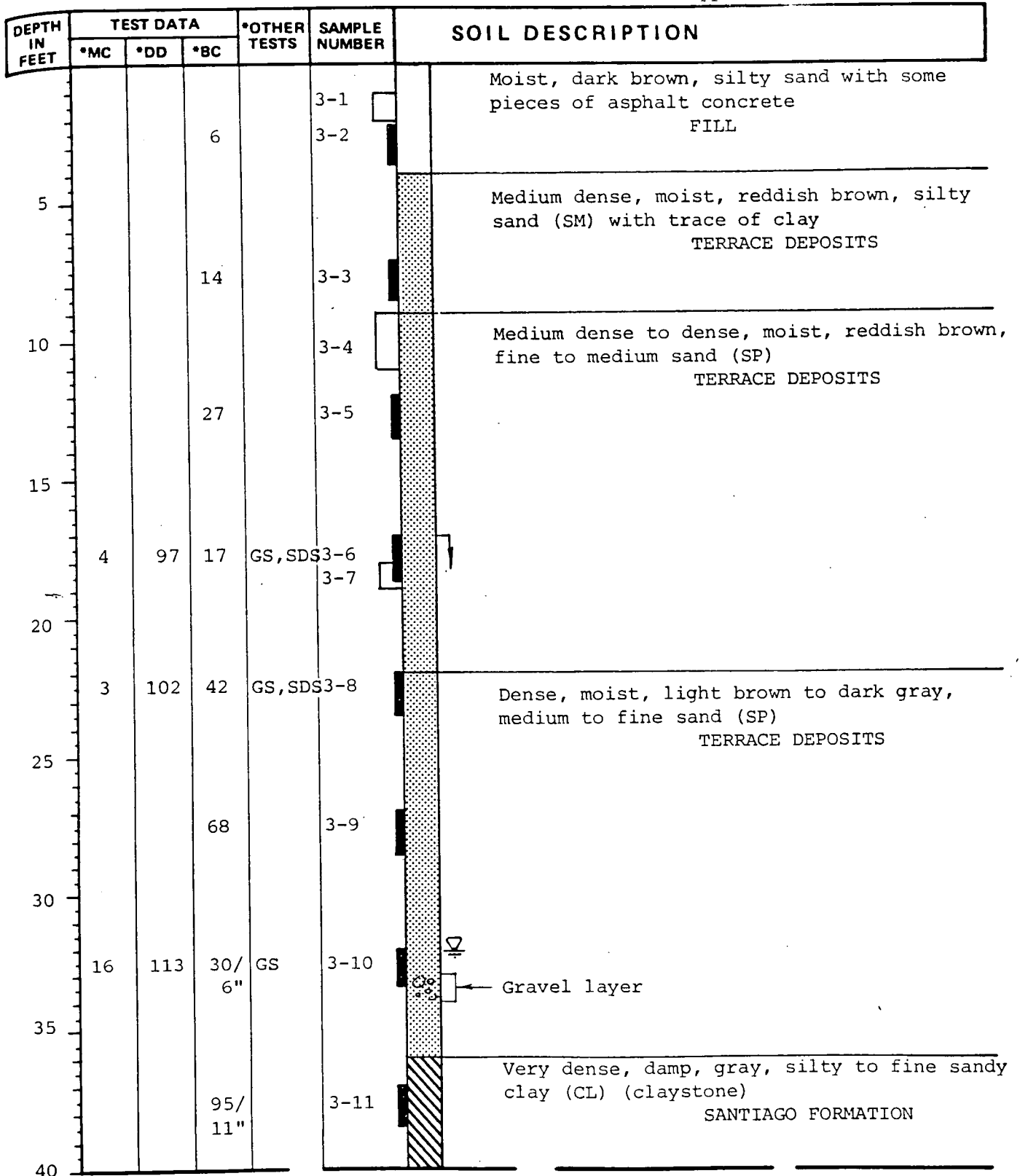



\*For description of symbols, see Figure B-1

Bottom of Hole

LOG OF TEST BORING 3 CARLSBAD BOULEVARD SEAWALL			
DRAWN BY: ch	CHECKED BY:	PROJECT NO: 542681-SIO1	DATE: 3-6-86
			FIGURE NO: B-5

Boring 3 (Cont'd)

DEPTH IN FEET	TEST DATA			*OTHER TESTS	SAMPLE NUMBER	SOIL DESCRIPTION
	*MC	*DD	*BC			
16	113	84/ 8"	GS, PI UCS= 18483 psf	3-12		(Continued) very dense, damp, gray, silty to fine sandy clay (CL) (claystone) SANTIAGO FORMATION
45						----- Grading to ----- Very dense, moist, gray, silty fine sand (SM) with cemented zones (sandstone) SANTIAGO FORMATION
50						Bottom of Hole
55						
60						
65						
70						
75						
80						

\*For description of symbols, see Figure B-1

LOG OF TEST BORING 3 (CONT'D) CARLSBAD BOULEVARD SEAWALL				
<b>DRAWN BY:</b> ch	<b>CHECKED BY:</b>	<b>PROJECT NO:</b> 542681-SIO1	<b>DATE:</b> 3-6-86	<b>FIGURE NO:</b> B-6



COBBLES	GRAVEL		SAND			SILT and CLAY
	Coarse	Fine	Coarse	Medium	Fine	

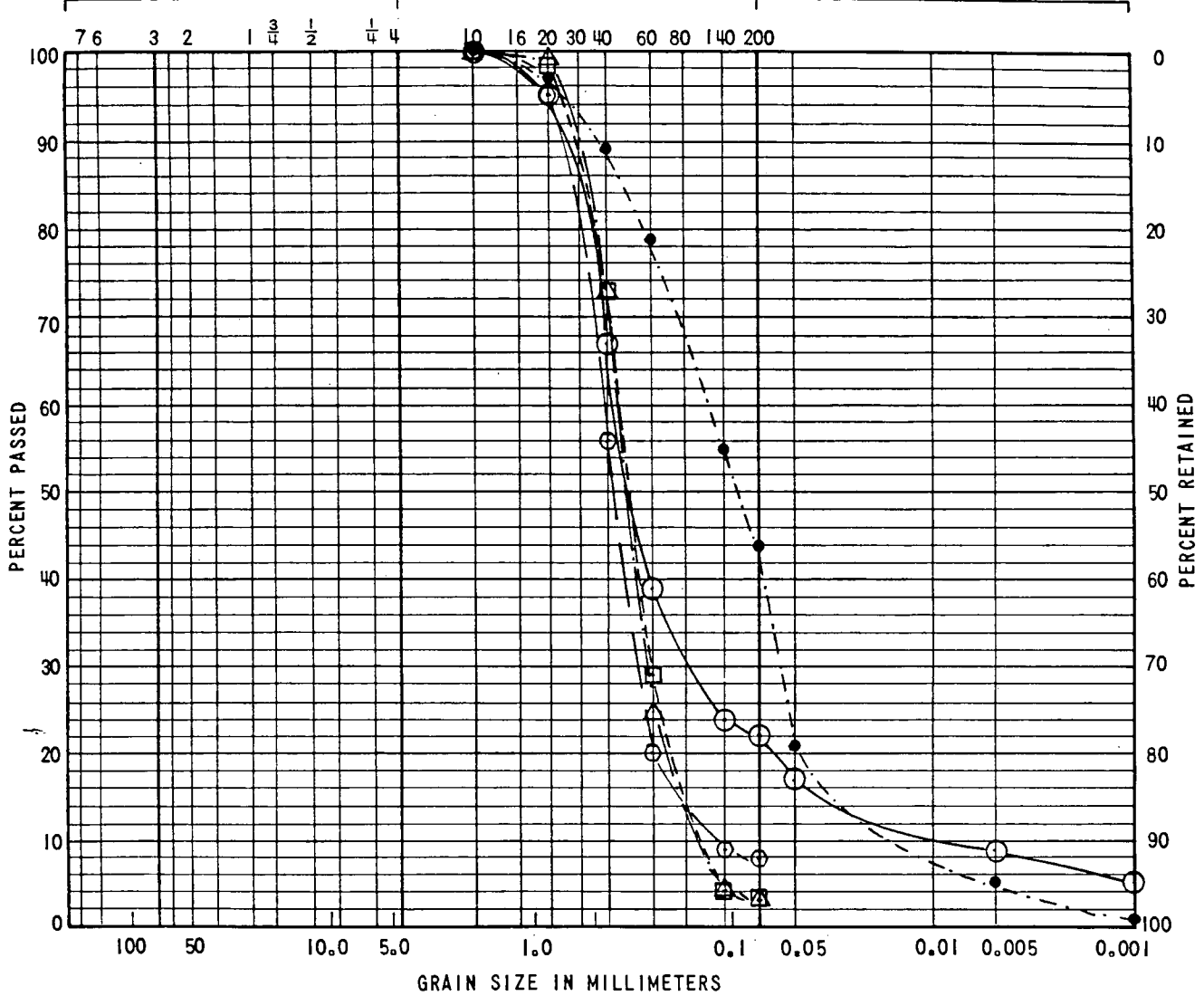

SAMPLE	CLASSIFICATION AND SYMBOL	*LL	*PI
○ 1-2	Silty sand (FILL)	--	--
⊙ 1-4	Medium to fine sand (SP)	--	--
△ 1-6	Medium to fine sand (SP)	--	--
◻ 1-8	Medium to fine sand (SP)	--	--
● 1-12	Silty fine sand (SM)	30	6

\*LL - Liquid Limit  
 \*PI - Plasticity Index

GRAIN SIZE DISTRIBUTION CURVES			
CARLSBAD BOULEVARD SEAWALL			
DRAWN BY: ch	CHECKED BY:	PROJECT NO: 542681-SIO1	DATE: 3-6-86
		FIGURE NO: B-7	

COBBLES	GRAVEL		SAND			SILT and CLAY
	Coarse	Fine	Coarse	Medium	Fine	

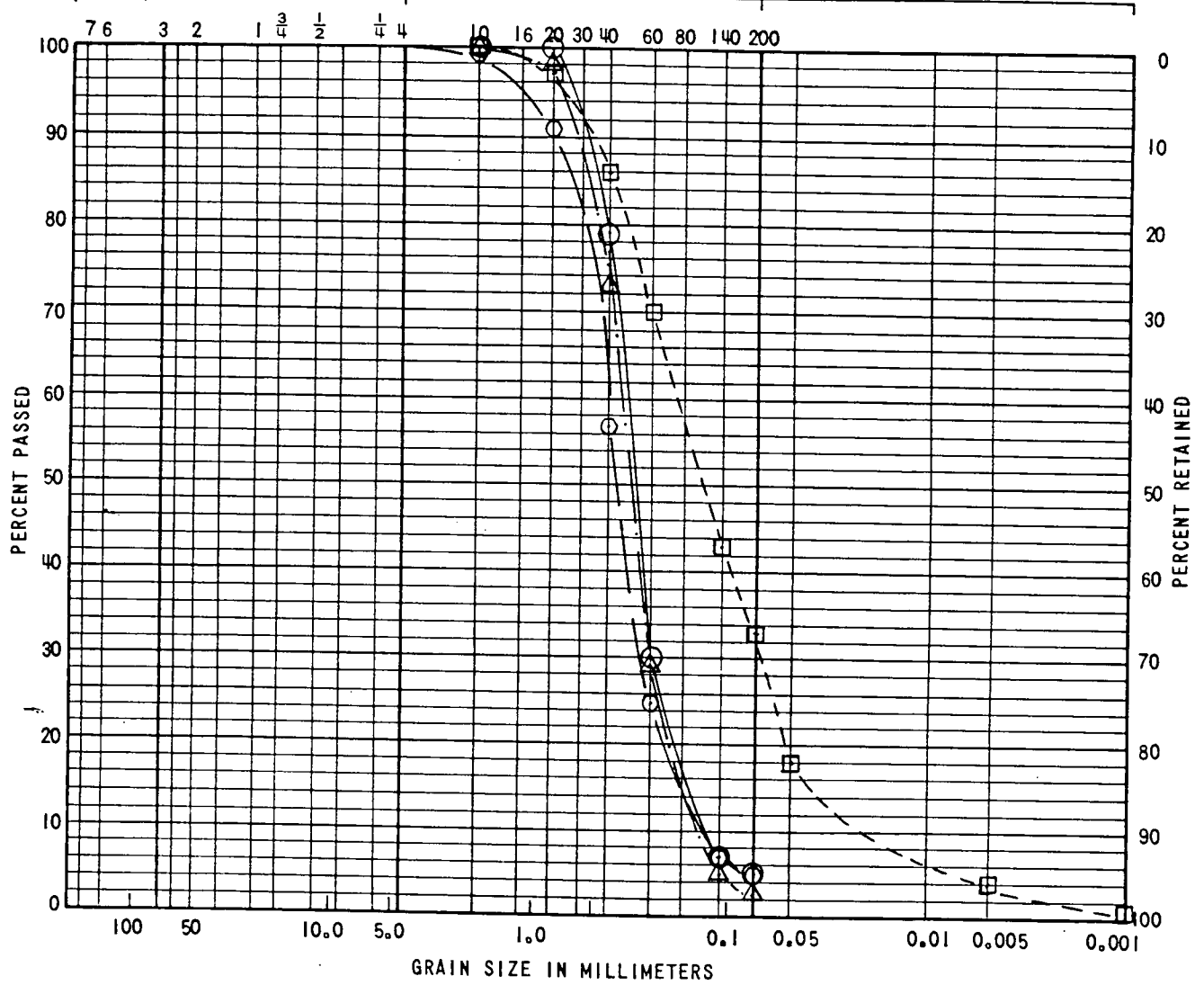

SAMPLE	CLASSIFICATION AND SYMBOL	*LL	*PI
○2-5	Fine sand (SP)	--	--
⊙2-7	Medium to fine sand (SP)	--	--
△2-9	Medium to fine sand (SP)	--	--
□2-12	Silty fine sand (SM)	30	6

\*LL - Liquid Limit  
\*PI - Plasticity Index

<b>GRAIN SIZE DISTRIBUTION CURVES</b>			
CARLSBAD BOULEVARD SEAWALL			
DRAWN BY: ch	CHECKED BY:	PROJECT NO: 542681-SIO1	DATE: 3-6-86
			FIGURE NO: B-8

COBBLES	GRAVEL		SAND			SILT and CLAY
	Coarse	Fine	Coarse	Medium	Fine	

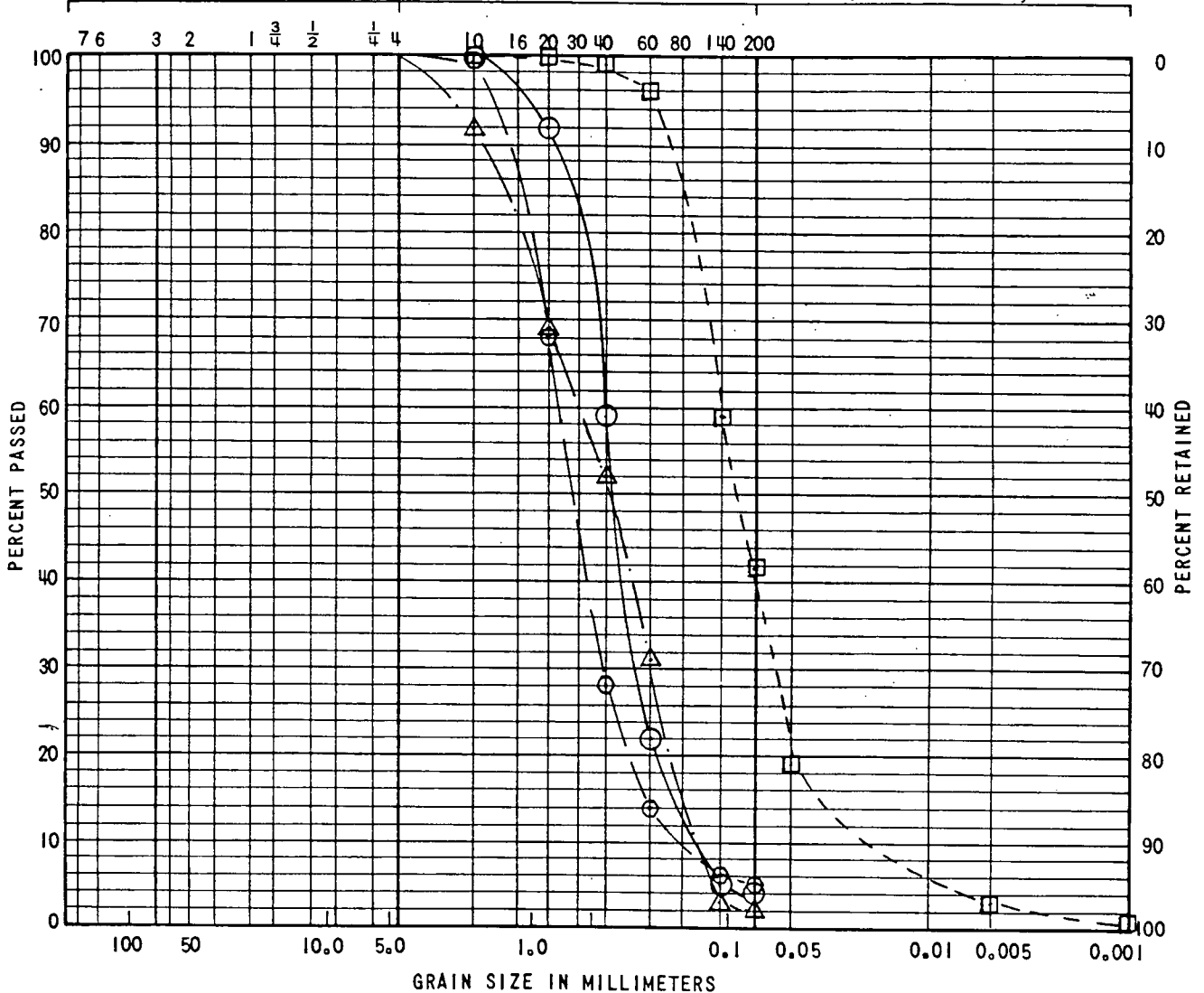

SAMPLE	CLASSIFICATION AND SYMBOL	*LL	*PI
○ 3-6	Medium to fine sand (SP)	--	--
○ 3-8	Medium to fine sand (SP)	--	--
△ 3-10	Medium to fine sand (SP)	--	--
□ 3-12	Silty fine sand (SM)	30	5

\*LL - Liquid Limit  
 \*PI - Plasticity Index

GRAIN SIZE DISTRIBUTION CURVES			
CARLSBAD BOULEVARD SEAWALL			
DRAWN BY: ch	CHECKED BY:	PROJECT NO: 542681-SIO1	DATE: 3-6-86
			FIGURE NO: B-9



COBBLES	GRAVEL		SAND			SILT and CLAY
	Coarse	Fine	Coarse	Medium	Fine	

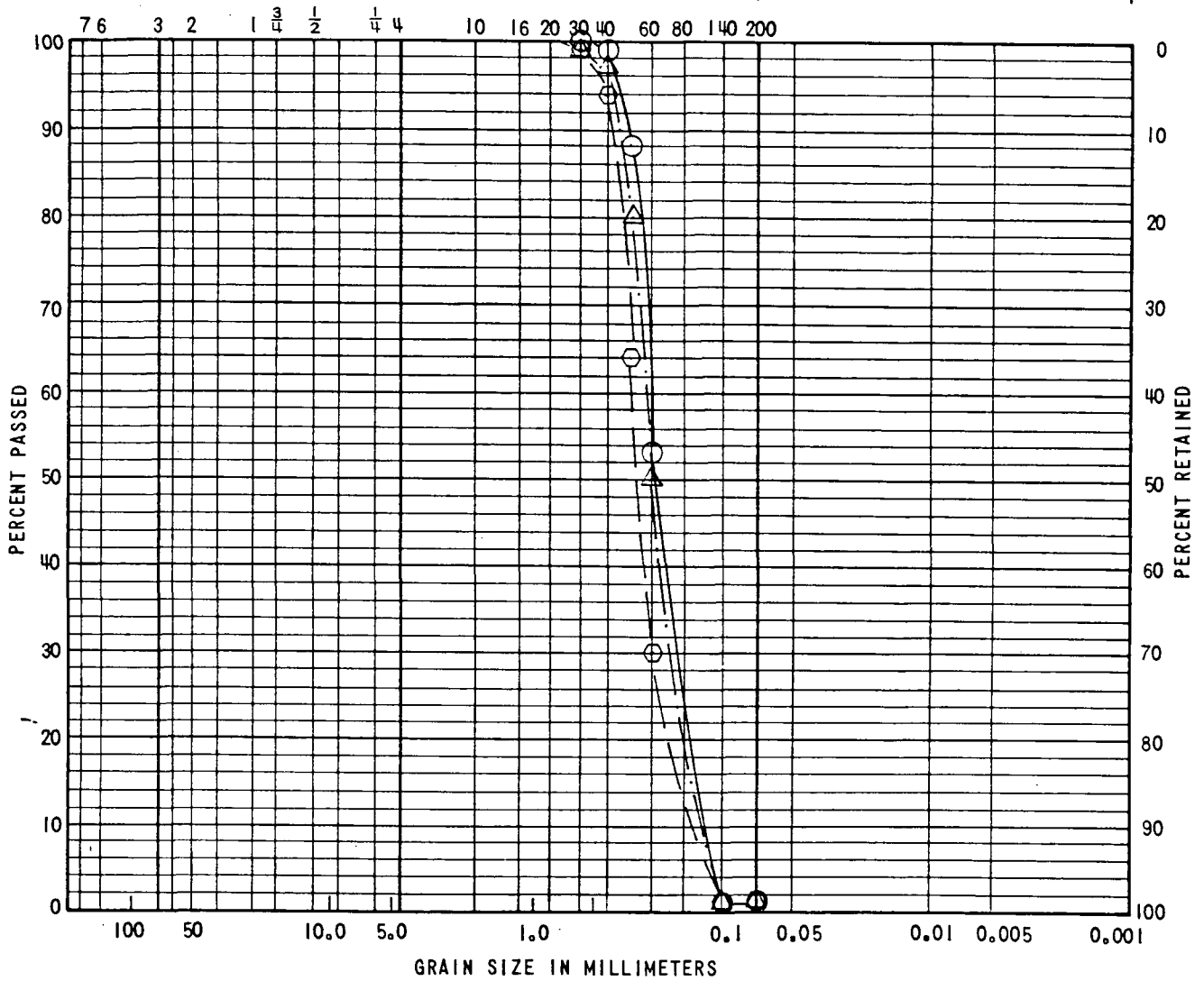

SAMPLE	CLASSIFICATION AND SYMBOL	*LL	*PI
○ 1	Beach sand - Poorly graded fine sand (SP)	--	--
□ 2	Beach sand - Poorly graded fine sand (SP)	--	--
△ 3	Beach sand - Poorly graded fine sand (SP)	--	--

Note: Samples were obtained from beach at south, middle and north ends of project

\*LL - Liquid Limit  
\*PI - Plasticity Index

<b>GRAIN SIZE DISTRIBUTION CURVES</b>				
CARLSBAD BOULEVARD SEAWALL				
DRAWN BY: ch	CHECKED BY:	PROJECT NO: 542681-SIO1	DATE: 4-7-86	FIGURE NO: B-10

WOODWARD-CLYDE CONSULTANTS

STRESS/STRAIN GRAPH

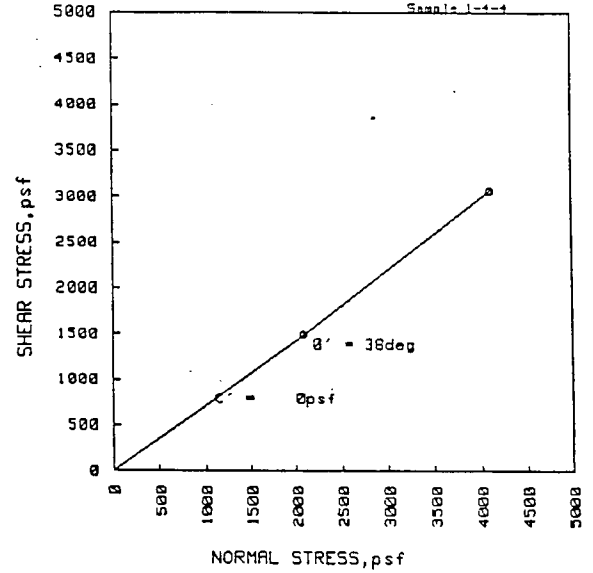
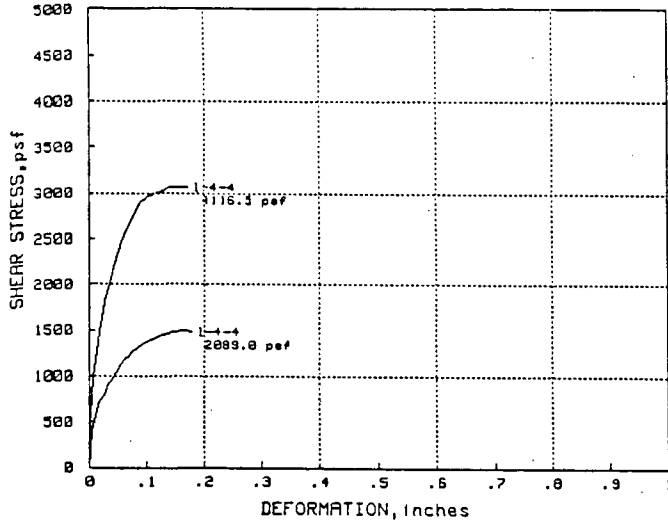

SAMPLE DATA				
Sample/Classification	Light brown, medium to fine sand (SP) Sample 1-4			
Specimen Number	1	2		
Height, inches	.814	.814		
Diameter, inches	1.94	1.94		
Initial Dry Density, pcf	110	109		
Initial Moisture Content, %	5	6		
Initial Saturation, %	25	29		
Final Dry Density, pcf	109	110		
Final Moisture Content, %	17	17		
Final Saturation, %	89	88		
Normal Stress, psf	2048.0	4096.0		

TEST DATA	
Type of Test:	Slow Direct Shear Test
Angle of Friction, Effective $\phi'$	= 37°
Cohesion, Effective $C' = 0$ psf	Rate of Shear, in/min .00028800

SLOW DIRECT SHEAR TEST			
CARLSBAD BOULEVARD SEAWALL			
DRAWN BY: ch	CHECKED BY:	PROJECT NO: 542681-SIO1	DATE: 3-6-86
			FIGURE NO: B-11

STRESS/STRAIN GRAPH

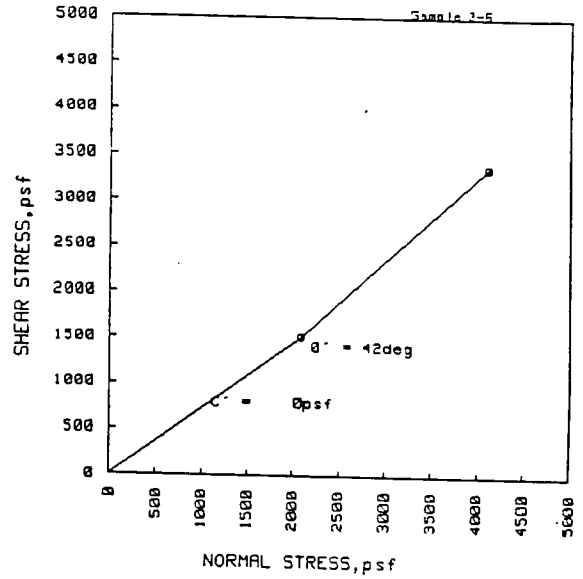
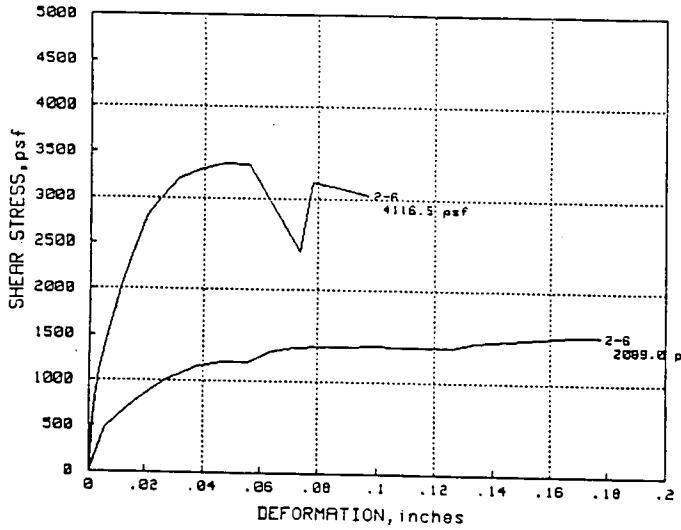

SAMPLE DATA				
Sample/Classification	Sample 2-6, Medium to fine sand (SP)			
Specimen Number	1	2		
Height, inches	.814	.814		
Diameter, inches	1.94	1.94		
Initial Dry Density, pcf	97	102		
Initial Moisture Content, %	5	6		
Initial Saturation, %	19	25		
Final Dry Density, pcf	100	104		
Final Moisture Content, %	24	22		
Final Saturation, %	96	98		
Normal Stress, psf	2089.0	4116.5		

TEST DATA	
Type of Test:	Slow Direct Shear Test
Angle of Friction, Effective $\phi'$	$39^\circ$
Cohesion, Effective $C'$	$0 \text{ psf}$
Rate of Shear, in/min	.00028800

SLOW DIRECT SHEAR TEST				
CARLSBAD BOULEVARD SEAWALL				
DRAWN BY: ch	CHECKED BY:	PROJECT NO: 542681-SI01	DATE: 3-26-86	FIGURE NO: B-12



STRESS/STRAIN GRAPH

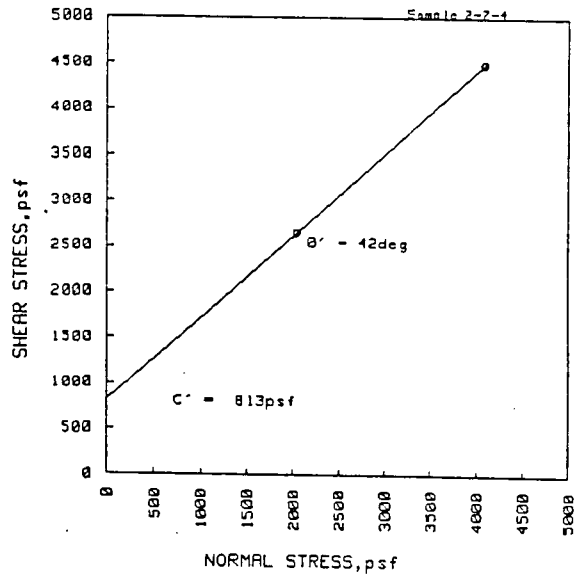
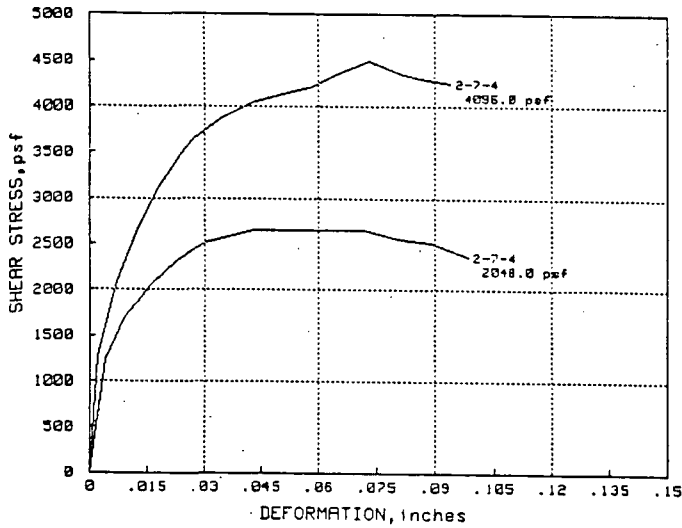

SAMPLE DATA					
Sample/Classification	Light brown, medium to fine sand (SP) Sample 2-7				
Specimen Number	1	2			
Height, inches	.814	.814			
Diameter, inches	1.94	1.94			
Initial Dry Density, pcf	97	92			
Initial Moisture Content, %	3	3			
Initial Saturation, %	10	9			
Final Dry Density, pcf	101	97			
Final Moisture Content, %	24	21			
Final Saturation, %	99	79			
Normal Stress, psf	2089.0	4116.5			

TEST DATA	
Type of Test: Slow Direct Shear Test	
Angle of Friction, Effective $\theta' = 42^\circ$	
Cohesion, Effective $C' = 800 \text{ psf}$	Rate of Shear, in/min .00028800

SLOW DIRECT SHEAR TEST			
CARLSABD BOULEVARD SEAWALL			
DRAWN BY: ch	CHECKED BY:	PROJECT NO: 542681-SIO1	DATE: 3-6-86
			FIGURE NO B-13

STRESS/STRAIN GRAPH

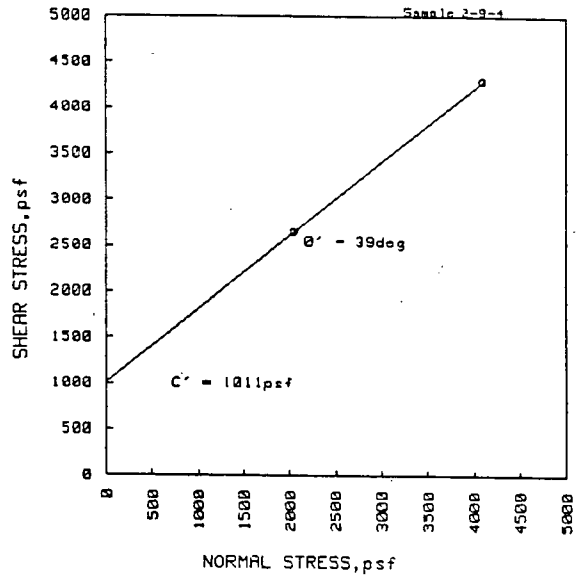
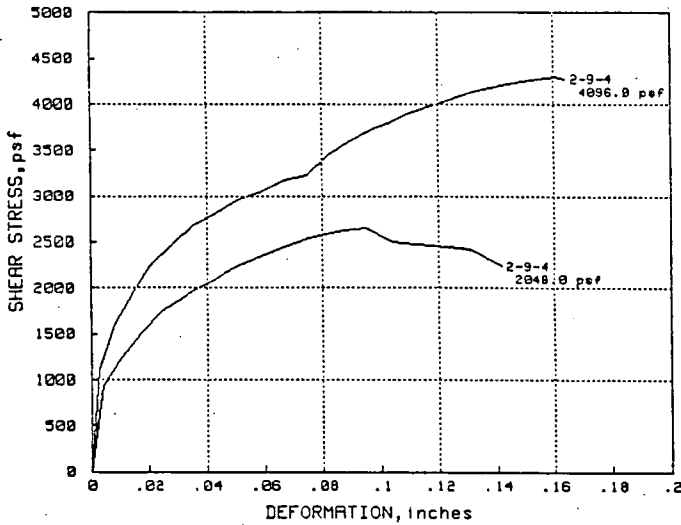

SAMPLE DATA				
Sample/Classification	Gray to pale brown, medium to fine sand (SP) Sample 2-9			
Specimen Number	1	2		
Height, inches	.814	.814		
Diameter, inches	1.94	1.94		
Initial Dry Density, pcf	96	98		
Initial Moisture Content, %	3	3		
Initial Saturation, %	11	11		
Final Dry Density, pcf	97	101		
Final Moisture Content, %	24	22		
Final Saturation, %	90	92		
Normal Stress, psf	2048.0	4096.0		

TEST DATA	
Type of Test: Slow Direct Shear Test	
Angle of Friction, Effective $\phi' = 39^\circ$	
Cohesion, Effective $C' = 1000$ psf	Rate of Shear, in/min .00028800

<b>SLOW DIRECT SHEAR TEST</b>			
CARLSBAD BOULEVARD SEAWALL			
DRAWN BY: ch	CHECKED BY:	PROJECT NO: 542681-SIO1	DATE: 3-6-86
			FIGURE NO: B-14

PLASTICITY CHARACTERISTICS			
Liquid Limit, %			
Plasticity Index, %			
Classification by Unified Soil Classification System			

COBBLES	GRAVEL		SAND		SILT & CLAY
	c	f	c	m	

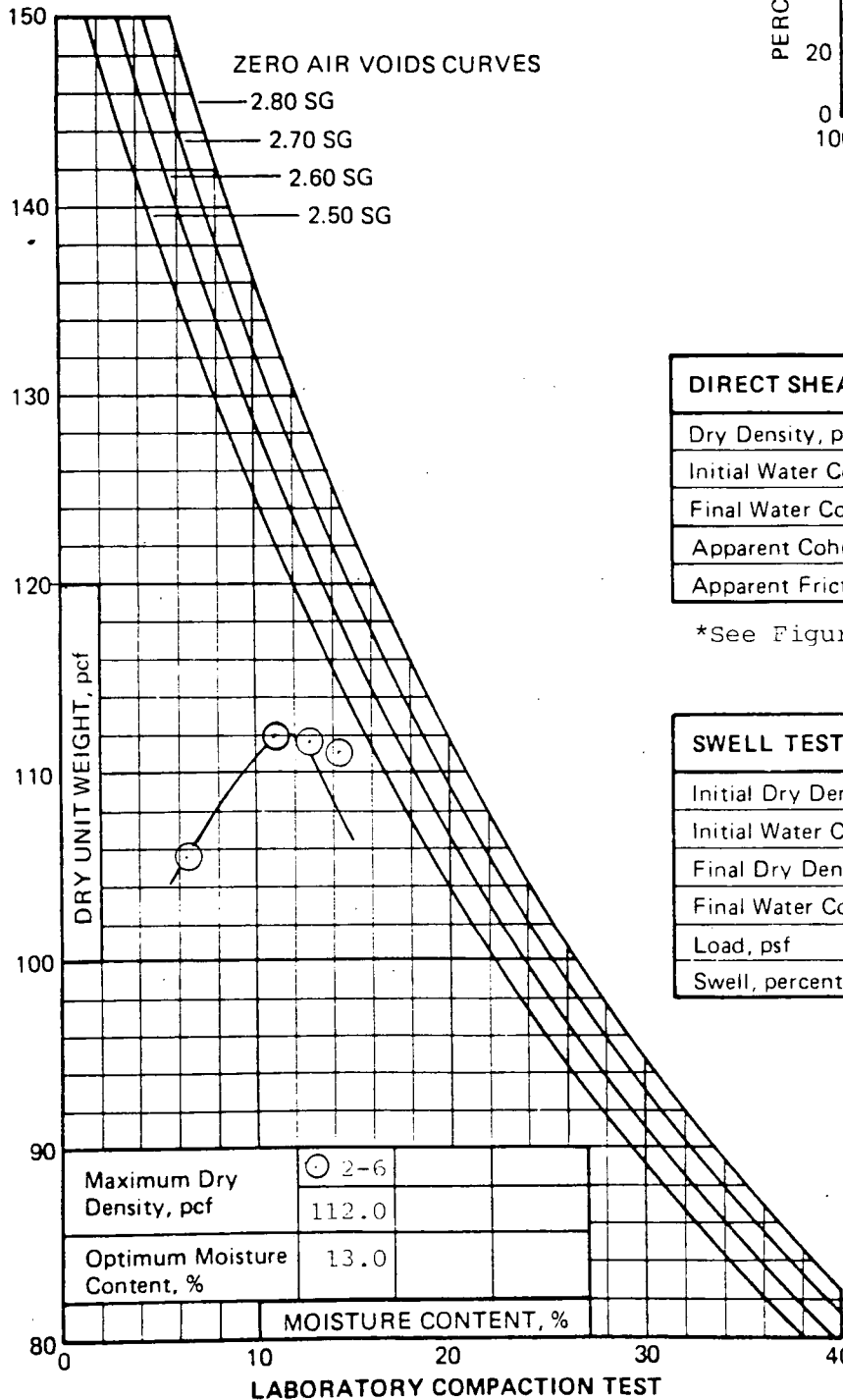
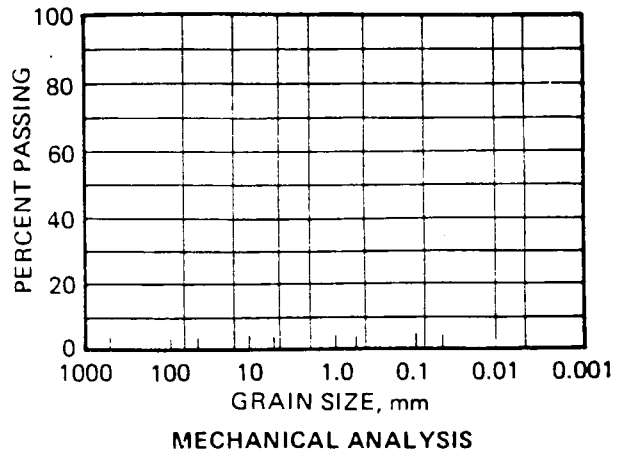

DIRECT SHEAR TEST DATA	2-6 *		
Dry Density, pcf	100		
Initial Water Content, %	6		
Final Water Content, %	23		
Apparent Cohesion, psf	0		
Apparent Friction Angle, degrees	39		

\*See Figure B-12

SWELL TEST DATA			
Initial Dry Density, pcf			
Initial Water Content, %			
Final Dry Density, pcf			
Final Water Content, %			
Load, psf			
Swell, percent			

SAMPLE LOCATION	

LABORATORY COMPACTION TEST METHOD: ASTM-D 1557-78 A

FILL SUITABILITY TESTS			
CARLSBAD BOULEVARD SEAWALL			
DRAWN BY: ch	CHECKED BY:	PROJECT NO: 542681-SI01	DATE: 3-26-86
			FIGURE NO: B-17



.Y 1 103 110 2 0 1 1 65 2 2 0 0 35 5

LABORATORY REPORT

Telephone (619) 425-1993

Established 1928

CLARKSON LABORATORY AND SUPPLY INC.  
350 Trousdale Dr. Chula Vista, Ca. 92010  
ANALYTICAL AND CONSULTING CHEMISTS

Date: 03-25-86

Purchase Order Number: Job #542681 SI01

Account Number: WOOX

To:

\*-----\*

Woodward Clyde  
3467 Kurtz St.  
San Diego, CA. 92110  
Attention: Chuck Elliot

Laboratory Number: SO 1210

Customers Phone No: L27 224-2911

Sample Designation:

\*-----\*

One soil sample marked Carlsbad Seawall,  
sample # 1-7. Job #542681 SI01.

ANALYSIS: By Test Method No. Calif. 643-C October 2, 1972 State of  
California Department of Public Works Division of Highways  
Materials and Research Department Method for Estimating the  
Service Life of Metal Culverts.

SAMPLE

pH 7.0

Water Added (ml)

100

50

50

50

50

50

50

50

Resistivity (ohm-cm)

4050

2840

2340

1770

1640

1520

1520

1520

The above results indicate 25 years to perforation for a 16 gauge  
metal culvert, and 57 years to perforation for a 10 gauge metal culvert.

Water Soluble Sulfates

0.009%



PETER B. STEAD

PBS/1tm

STRESS/STRAIN GRAPH

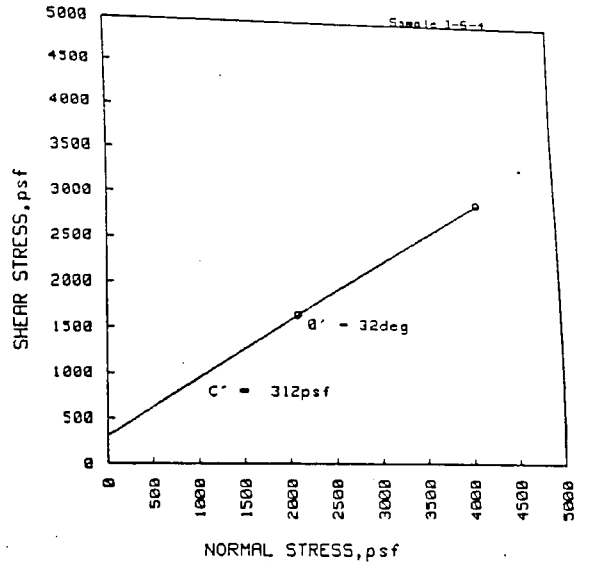
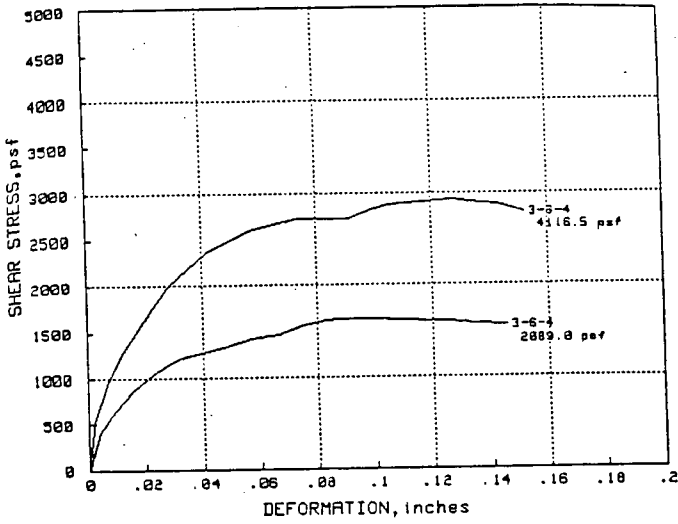

SAMPLE DATA					
Sample/Classification	Pale brown, medium to fine sand (SP)				Sample 3-6
Specimen Number	1	2			
Height, inches	.814	.814			
Diameter, inches	1.94	1.94			
Initial Dry Density, pcf	97	97			
Initial Moisture Content, %	4	4			
Initial Saturation, %	14	14			
Final Dry Density, pcf	99	100			
Final Moisture Content, %	23	23			
Final Saturation, %	93	92			
Normal Stress, psf	2089.0	4116.5			

TEST DATA	
Type of Test: Slow Direct Shear Test	
Angle of Friction, Effective $\theta' = 32^\circ$	
Cohesion, Effective $C' = 300 \text{ psf}$	Rate of Shear, in/min .00028800

SLOW DIRECT SHEAR TEST			
CARLSBAD BOULEVARD SEAWALL			
DRAWN BY: ch	CHECKED BY:	PROJECT NO: 542681-SI01	DATE: 3-6-86
			FIGURE NO. B-15

STRESS/STRAIN GRAPH

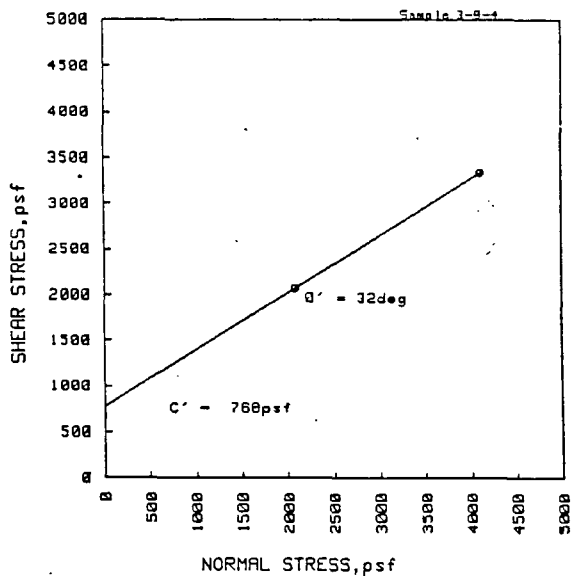
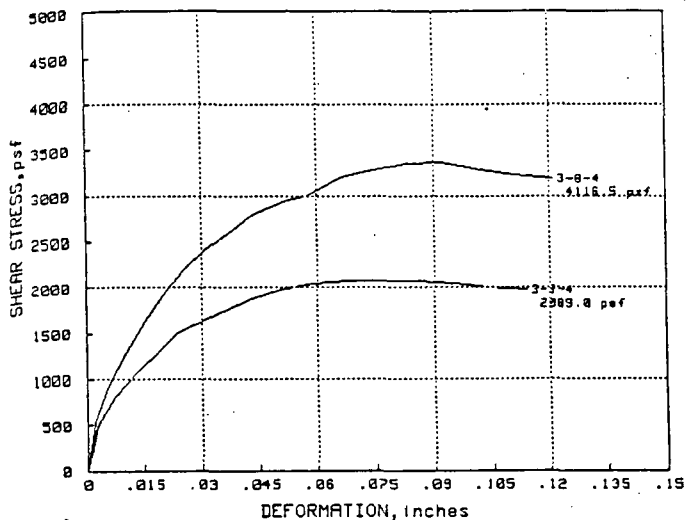

SAMPLE DATA					
Sample/Classification	Light brown, medium to fine clean sand (SP) Sample 3-8				
Specimen Number	1	2			
Height, inches	.814	.814			
Diameter, inches	1.94	1.94			
Initial Dry Density, pcf	103	101			
Initial Moisture Content, %	3	4			
Initial Saturation, %	14	15			
Final Dry Density, pcf	103	102			
Final Moisture Content, %	21	21			
Final Saturation, %	92	87			
Normal Stress, psf	2089.0	4116.5			

TEST DATA	
Type of Test:	Slow Direct Shear Test
Angle of Friction, Effective $\phi'$	= 32°
Cohesion, Effective $C'$	= 750 psf
Rate of Shear, in/min	.00028800

<b>SLOW DIRECT SHEAR TEST</b> CARLSBAD BOULEVARD SEAWALL			
DRAWN BY: ch	CHECKED BY:	PROJECT NO: 542681-SI01	DATE: 3-6-86
			FIGURE NO: B-16