

**C**

**SMP COMPLETE STREET  
DESIGN GUIDELINES**

A blue-tinted photograph of a street scene in Carlsbad, California. In the foreground, a large wooden archway spans the street with the word 'CARLSBAD' in large, white, block letters. Below the archway, a street with cars and pedestrians is visible. The background shows buildings and trees. The image is overlaid with a green and white wavy graphic at the top and bottom.

# CARLSBAD SUSTAINABLE MOBILITY PLAN

COMPLETE STREETS DESIGN GUIDELINES - DRAFT

FEBRUARY 2020

# DRAFT

## TABLE OF CONTENTS

<b>1 INTRODUCTION .....</b>	<b>1</b>
BACKGROUND .....	1
PURPOSE AND NEED .....	1
OBJECTIVES .....	2
INTENDED AUDIENCE .....	2
SUPPORTING DOCUMENTS .....	3
<b>HOW PROJECTS HAPPEN IN CARLSBAD .....</b>	<b>4</b>
PROJECT DECISIONS .....	4
PHASE 1: PROJECT IDENTIFICATION .....	5
PHASE 2: PRELIMINARY DESIGN .....	6
PHASE 3: REVIEW AND COORDINATION .....	6
PHASE 4: PERFORMANCE MONITORING .....	6
<b>2 STREET CROSS SECTIONS .....</b>	<b>9</b>
FRAMEWORK .....	9
FUNCTION, CONTEXT, AND MODAL EMPHASIS .....	10
FUNCTION .....	10
CONTEXT .....	10
MODAL EMPHASIS .....	12
STREET TYPOLOGIES .....	14
CROSS SECTIONS .....	16



# DRAFT

<b>3</b>	<b>WALK ZONE .....</b>	<b>21</b>
	SIDEWALKS .....	22
	SIDEWALK DINING .....	24
<b>4</b>	<b>AMENITY ZONE .....</b>	<b>26</b>
	BUS PASSENGER WAITING AREA .....	28
	BUS SHARE STATIONS .....	30
	MICRO-MOBILITY DROP ZONES .....	32
	LANDSCAPING .....	34
<b>5</b>	<b>ACCESS ZONE .....</b>	<b>38</b>
	BUS LOADING ZONE .....	40
	BUS BULBS .....	42
	ON-STREET PARKING .....	44
	DRIVEWAYS .....	46
	LOADING ZONES .....	48
	SHARED USE MOBILITY ZONES .....	50
	BIKE CORRALS .....	52
	PARKLETS .....	54



# DRAFT

<b>6 BICYCLE FACILITIES .....</b>	<b>56</b>
FACILITY SELECTION GUIDANCE .....	58
EXAMPLE OF EACH BIKEWAY TYPE .....	58
CLASS I BIKEWAYS .....	58
SIDEPATH .....	60
CLASS II BIKEWAYS .....	62
CLASS III BIKEWAYS .....	64
CLASS IV BIKEWAYS .....	66
BIKE BOULEVARDS .....	68
SELECTING THE APPROPRIATE BIKEWAY TYPES .....	70
DESIGN CONSIDERATIONS FOR BIKEWAY SEGMENTS .....	71
DESIGN CONSIDERATIONS FOR INTERSECTIONS .....	75
MIDBLOCK TRAIL CROSSINGS .....	81
<b>7 CARTWAY .....</b>	<b>82</b>
SPEED MANAGEMENT PRINCIPLES .....	84
SPEED, EXPOSURE, AND PREDICTABILITY .....	84
SPEED LIMITS, DESIGN SPEED AND OPENING SPEED .....	85



# DRAFT

NEIGHBORHOOD STREET SPEED MANAGEMENT .....	88
CHICANE .....	88
CHOKER OR NECK-DOWN .....	90
SPEED HUMPS .....	92
TRAFFIC CIRCLES .....	94
DIVERTERS .....	96
ARTERIAL STREET SPEED MANAGEMENT .....	98
ROAD DIETS .....	98
SIGNAL MODIFICATIONS .....	100
MEDIANS .....	102
SPEED MANAGEMENT TOOLS .....	104
TRANSIT OPERATIONS .....	105
BUS PRIORITY TREATMENTS .....	105
TEMPORARY TRAFFIC CONTROL .....	108
MAINTENANCE .....	109
<b>8 INTERSECTIONS AND CROSSINGS .....</b>	<b>110</b>
DESIGN CONTROLS .....	112
DESIGN VEHICLE .....	112



# DRAFT

CORNER DESIGN .....	113
INTERSECTION DESIGN .....	115
COMPACT INTERSECTIONS .....	115
INTERSECTION CONTROLS .....	118
SELECTION OF INTERSECTION CONTROL .....	118
PEDESTRIAN RECALL SIGNALS .....	120
LEADING PEDESTRIAN INTERVAL .....	122
RECTANGULAR RAPID FLASHING BEACON .....	124
PEDESTRIAN HYBRID BEACON (PHB) .....	126
PEDESTRIAN SCRAMBLE .....	128
PEDESTRIAN CROSSINGS .....	128
CROSSING LOCATIONS .....	130
MARKED SIDEWALK .....	132
MEDIAN REFUGE ISLAND .....	134
CURB EXTENSIONS .....	136
ADA COMPLIANCE .....	138

<b>8 CASE STUDIES .....</b>	<b>141</b>
-----------------------------	------------

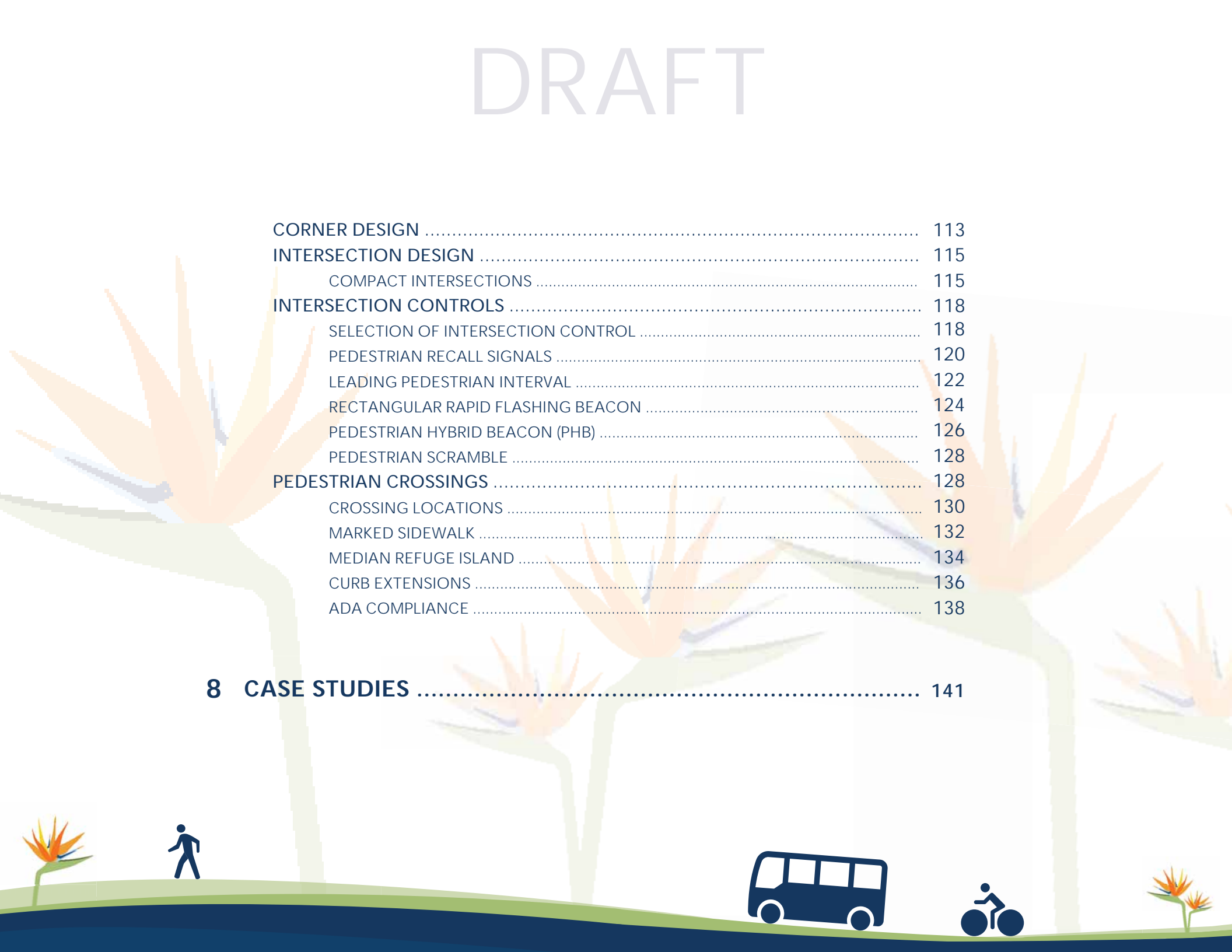

# DRAFT





DRAFT

# 1 INTRODUCTION



## INTRODUCTION

## **BACKGROUND**

### PURPOSE AND NEED

The purpose of this guide is to provide a set of best practices that can be incorporated by the City of Carlsbad to create safer, more vibrant streets that serve all users going forward. These guidelines were developed using best practices in street design from Carlsbad, San Diego County, the state of California, and around the world. As such, they are intended to evolve and adapt to incorporate new treatments and techniques as they are developed and proven successful. These standards are meant only to guide future street design work in Carlsbad. While there may be streets that exist in Carlsbad today that are not consistent with these standards, it is intended that those conditions be addressed over time as street reconstruction or resurfacing projects are proposed.

# DRAFT

## OBJECTIVES

This design guide supports the objectives of the Sustainable Mobility Plan to help improve transportation-related safety, reduce emissions, and increase travel choices within the City of Carlsbad. Key to this vision is the principle of “8 to 80 cities” meaning that the transportation network should be designed for users of all ages and abilities. The concept suggests that if a city is designed for the use and needs of an 8 year old and an 80 year old then it should be safe and comfortable for the use of everyone. Objectives of this design guide are as follows:

- Delineate high-quality design principles and practices for multimodal street design
- Emphasize network connectivity as an underpinning of multimodal design
- Provide a performance measurement and evaluation framework to assess design decisions
- Update Engineering Standards for consistency with Mobility Element
- Improve intersection design to enhance safety for all users and provide opportunities for pedestrian improvements

## INTENDED AUDIENCE

While primarily a tool for City staff use, these guidelines are a public document that will be a policy and design resource for a variety of stakeholders engaged in the design and decision-making for transportation projects. City departments, design professionals, private developers, and consultants should all use these guidelines as a reference in their work. The guidelines will also be relevant to other transportation agencies operating in and around Carlsbad. State highways maintained by the California Department of Transportation (Caltrans) may intersect with streets designs found in these guidelines. Caltrans may also use these guidelines to inform their own street design decisions within the City of Carlsbad. Finally, the guidelines will also be useful to the North County Transit District (NCTD) which operates transit services on Carlsbad streets. NCTD can use the guidelines to work with the City to ensure bus shelters, transit amenities located along the street, and transit routes work together to achieve a seamless transportation network for city residents.



## SUPPORTING DOCUMENTS

The development of these guidelines builds on national research, engineering standards, and best practices. Baseline precedents for these guidelines are set by the California Manual for Uniform Traffic Control Devices (CAMUTCD) and national standards such as the Geometric Design of Highways and Streets published by the American Association of State Highway and Transportation Officials (AASHTO) and the FHWA. The National Association of City Transportation Officials (NACTO) Urban Street Design Guide and Urban Bikeways Design Guide provides a secondary source on complete streets best practices. Caltrans endorsed the NACTO design guides in 2014 and to the maximum extent possible; the principles and approach of these documents has been reflected. The guidelines refer to local policies and documents throughout, such as:

- The Carlsbad General Plan Mobility Element
- Carlsbad Engineering Standards
- Carlsbad Residential Traffic Management Program
- California Manual for Uniform Traffic Control Devices (CAMUTCD)
- AASHTO Geometric Design of Highways and Streets, better known as the "Green Book"

- AASHTO Guide for the Development of Bicycle Facilities
- FHWA Manual on Uniform Traffic Control Devices, or MUTCD
- ITE Traffic Engineering Handbook
- ITE Implementing Context Sensitive Design on Multimodal Thoroughfares
- NACTO Urban Street Guide
- NACTO Urban Bikeway Guide
- NACTO Transit Street Design Guide

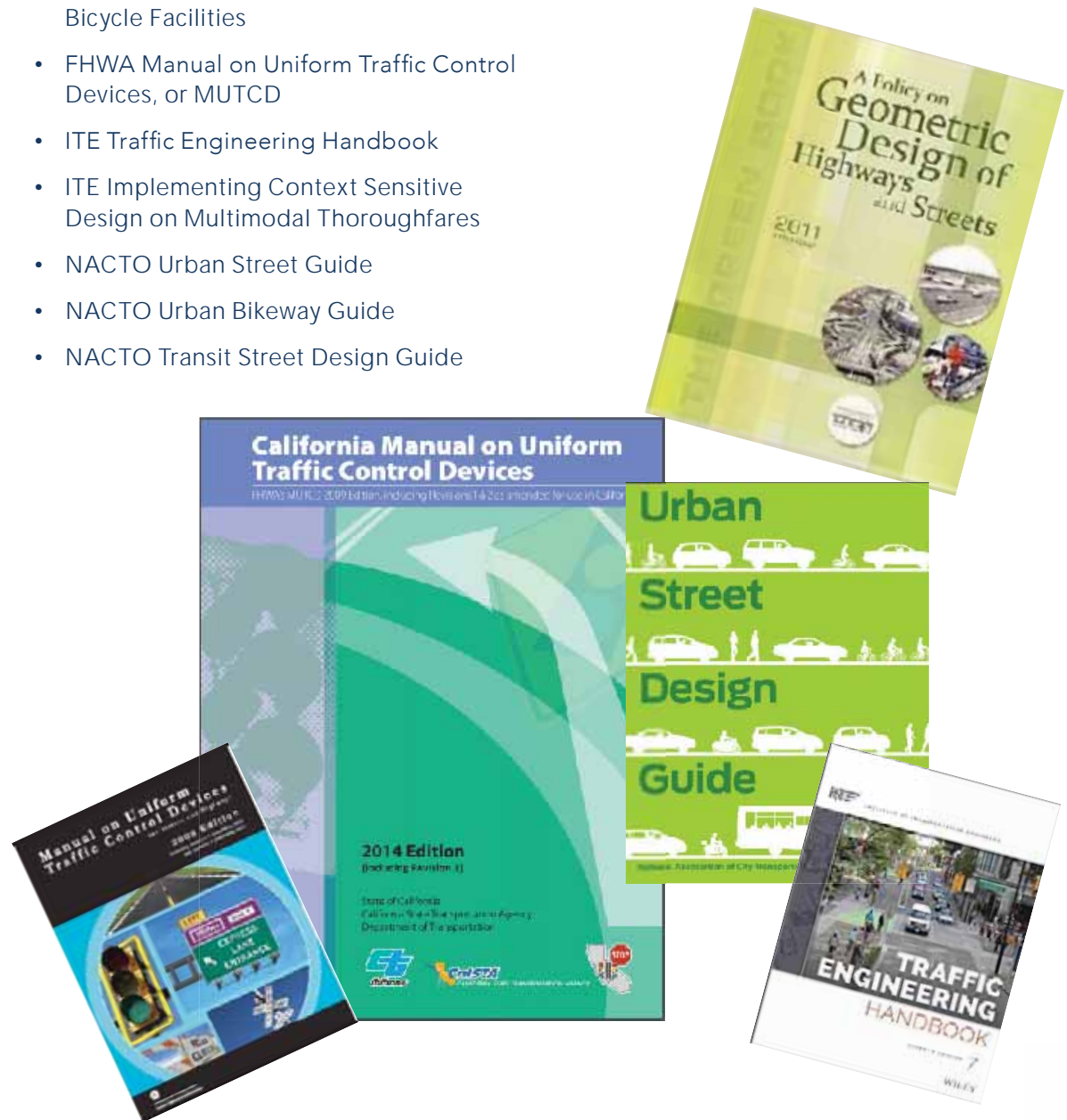

# HOW PROJECTS HAPPEN IN CARLSBAD

## PROJECT DECISIONS

Designing streets often entails making tradeoffs about the use of limited rights of way. This document is meant to establish guidance for such street design decisions in Carlsbad using the best information available. As such, the hierarchy of information to be used is as follows:

- 1 Legal Compliance (State)
- 2 Local Data and Research
- 3 National Data and Research
- 4 Anecdotal Observations
- 5 Engineering Standards (how things have been conducted historically)

### PHASE 1: PROJECT IDENTIFICATION



### PHASE 2: PRELIMINARY DESIGN



### PHASE 3: REVIEW & COORDINATION



### PHASE 4: PERFORMANCE MONITORING



## PHASE 1



### PROJECT IDENTIFICATION

Street design projects typically initiate from one of four project types: maintenance and operations projects, capital improvement projects, private development projects, and partner agency projects (i.e. Caltrans). Each of these project types has a different set of needs and opportunities that informs physical changes in the street design. Key steps of this phase include:

- Define the project, including boundaries
- Establish performance metrics related to specific desired outcomes and define methods for measurement
- Generate ideas and basic design features
- Identify any overlapping projects that could be coordinated
- Determine if supplementary funding can be obtained for additional improvements, beyond original scope of project
- Propose a design and construction timeline
- Estimate the project costs

### MAINTENANCE AND OPERATIONS

These projects arise from routine maintenance needs, safety interventions and/or operational changes. Projects of this type may include street resurfacing, pavement markings/re-striping, landscaping, street tree plantings, signage/signalization changes, street furnishings, sidewalk repairs, and curb repairs.

### CAPITAL IMPROVEMENT

Capital projects typically provide the most profound change in street environment and function, but are also less frequent. Capital designs often require an intensive public engagement process and broad coordination across departments. Given the typically higher cost and greater complexity of these projects, capital projects may take several months to years to be fully planned, designed, and implemented. Whenever possible, capital projects should be phased to coincide with maintenance needs. Projects of this type may include full street reconstruction, major utility improvements, comprehensive streetscaping, and lane and/or curb reconfigurations.

### PRIVATE DEVELOPMENT

When private development projects impact the street or sidewalk during construction, they must rebuild the street and affected portions or elements within it to the same standards and expectations as for public projects. These provide an opportunity to ensure that improvements are made in alignment with community goals. While improvements may occur in only segments of a block, they contribute to the incremental transformation of a street. Projects of this type may include repair or reconstruction of the sidewalk and amenity zones, changes to curbs or curb-cuts, utility infrastructure, landscaping, lighting, street furnishings, repair or reconstruction of the roadway, sidewalk, and parking and/or lane closures for construction.

### PARTNER AGENCY

While these design guidelines represent the desires of the City, some streets such as State Routes are under the jurisdiction and control of a partner agency (i.e. Caltrans). While the agency's standards may be the controlling guidance, these guidelines should serve as a starting point for negotiation of expectations and variances from partner standards.

## PHASE 2



### PRELIMINARY DESIGN

This design guide recognizes that all street user needs must be met by the system, but individual streets may emphasize certain uses over others as a necessary design balance. Examples of potential trade-offs include: choices between wider sidewalks or a wider roadway; providing bicycle facilities or providing on-street parking; vehicle volumes or transit service reliability. Key elements of this phase are as follows:

- Examine the Carlsbad Mobility Element roadway classification to understand the context for each street.
- Understand the context of the street and its role in the overall transportation system.
- Collect and analyze any relevant data.
- Establish a transparent community engagement/decision-making process.
- Determine the preferred elements for the site.
- Identify any conflicts between those elements and the street dimensions.
- Explore modifications of the design alternatives to meet the greatest number of needs.
- Select a preferred alternative, taking community input into consideration.

## PHASE 3



### REVIEW & COORDINATION

Project designs will be reviewed to ensure they are both compliant with all city standards and advancing the objectives of this guide.

- Maintenance and operations projects will be reviewed by maintenance and operations staff to identify any opportunities to further align the street with the goals of this guide.
- Capital improvement projects will be reviewed by the designated street design staff, who will consult with maintenance staff for coordination purposes.
- Private development projects will be responsible for meeting the street design standards as part of the site review process; planning staff will coordinate with designated street design staff as necessary.
- Partner agency projects will be recommended to follow the standards set out by this guide and coordinate with City staff as appropriate.

## PHASE 4



### PERFORMANCE MONITORING

Both before and after a project is constructed, data should be collected for the purpose of performance monitoring. Monitoring and measurement are important components of street design that are often neglected due to limited resources. This data is invaluable for verifying that street designs function as intended, and also for informing future design and planning decisions. It will be critical to establish a system for collecting, managing, and analyzing this data. This should be done for any project that requires a public input process.

Performance metrics and methods for measurement should be identified during the initial project definition process. Those methods may be quantitative (e.g. number of cyclists, number of crashes, etc.) or qualitative (e.g. online preference surveys, intercept surveys, etc.). Data should be recorded for an appropriate period of time both prior to and after implementation.

# DRAFT





An aerial photograph of a residential street. The street is paved and has several cars parked along the side. There are many trees, some with green leaves and some with brown leaves, suggesting a mix of vegetation. In the background, there are houses with brown roofs. The overall scene is a typical suburban neighborhood.

# 2 STREET CROSS SECTIONS

## 2

### STREET CROSS SECTIONS

#### FRAMEWORK

These guidelines introduce an approach to street design that seeks to ensure streets match their intended purpose within the context of the community. A holistic approach to street design takes into account the differing conditions and contexts of each street. Streets with different surrounding land uses, constraints, and significance for modes of transportation each require design considerations and treatments unique to those circumstances.

These guidelines build upon the street classification system set up in the General Plan. The system, as outlined here, will consider the transportation functional emphasis, land-use characteristics, development density, and surrounding context of each street. The resulting street types are intended to inform planning decisions when altering existing streets and sidewalks and when reviewing new streets and sidewalks as part of development projects.

# FUNCTION, CONTEXT, AND MODAL EMPHASIS

## FUNCTION

The mobility function is the key characteristic that defines the design of the traveled way, or the area between the two curbs, for mobility and access. Some communities use the FHWA Functional Classifications (arterial, collector, local) and some use names that they feel better reflect those streets' role in the network. The mobility function might consider elements such as the expected mix of modes, the volume of people movement, the general lengths of trips handled by the corridor, access control requirements, etc.

The Street System proposed in the City's currently adopted General Plan Mobility Element provides the functional classifications for roadways in Carlsbad.

## CONTEXT

Conventional street design practice has long favored only the wishes of automobile drivers when making street design decisions. This strategy has encouraged designing streets for speeding, and has created environments that are unpleasant for and often unsafe for other users. Changing this strategy to design streets based on a target speed keyed to the needs of all users can help to reduce speeding, and provide a safer environment for people to not only drive, but to park, bike, and walk as well. Well-designed streets should match the context of the areas that they serve. Physical characteristics such as the placement and height of buildings, the ground-floor uses within those buildings, and landscaping should pair with streets designed to match the needs of users.

**Urban Village:** This context represents a compact mix of uses that has a more "urban feel" than the rest of Carlsbad. Buildings are typically set at the edge of the street and contain uses that generate multimodality. Uses within the Carlsbad Village & Barrio Master Plan boundaries primarily reflect this context.

**Suburban:** Suburban contexts serve lower density employment centers, industrial areas, or residential land uses where buildings are set back from the road and spread further apart. Suburban areas are typically dominated by motor vehicle traffic. Uses outside the Carlsbad Village & Barrio Master Plan boundaries primarily reflect this context.

# DRAFT

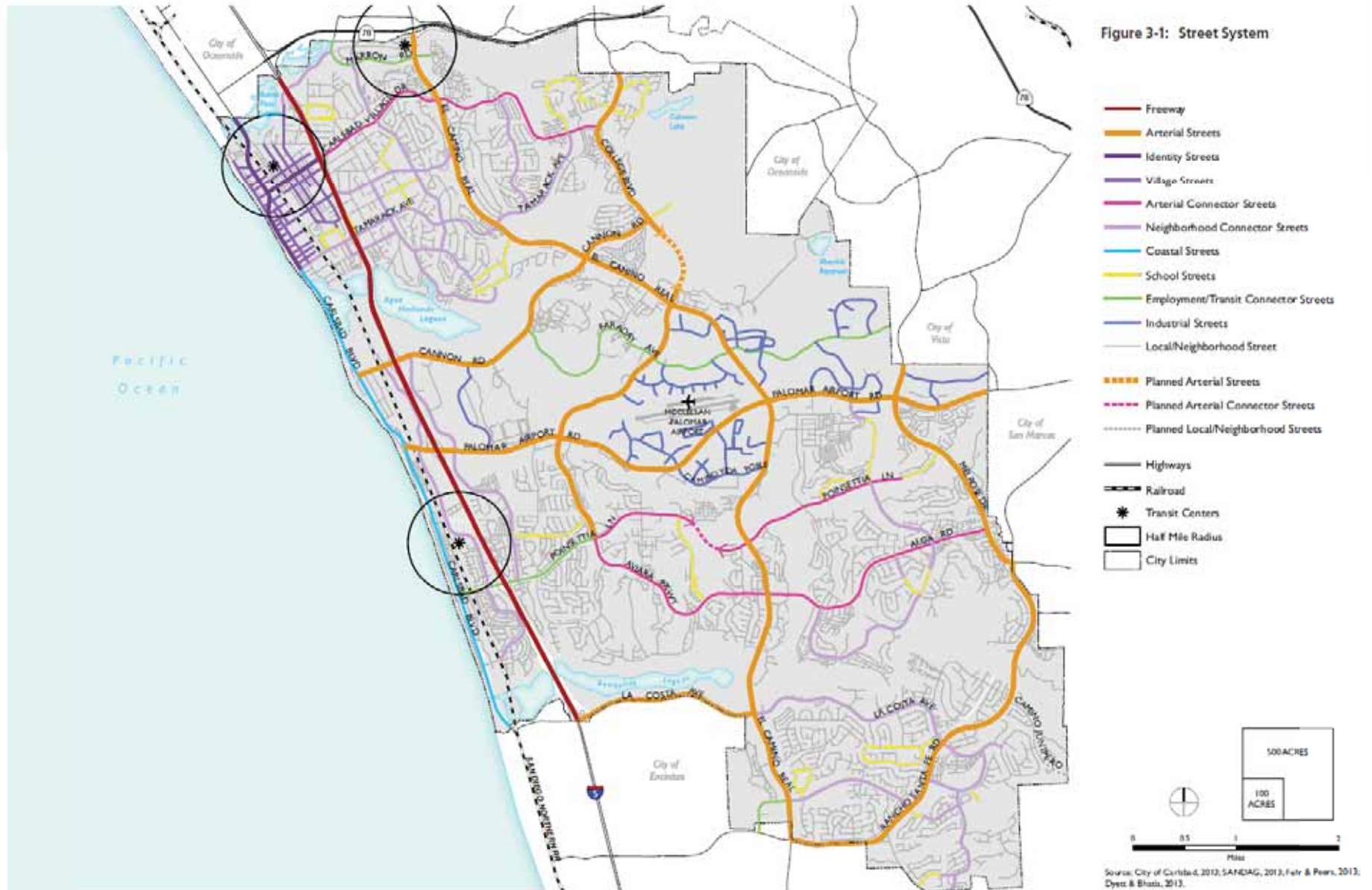

## MODAL EMPHASIS

Modal needs of specific users are highlighted below:

### PEDESTRIANS



Users who travel on foot or with assist devices, such as wheelchairs, are the most vulnerable users of the street. At the most basic level this group is supported with a clear path of travel on sidewalks, safe and frequent opportunities to cross streets, and buffering between conflicting modes.

### BICYCLISTS



Bicyclists are exposed and vulnerable users of the street who need to be accommodated with safe and comfortable facilities. Bicyclists have very levels of skill and comfort. The type of bicycle facilities that feel safe and comfortable vary based on a combination of motorist speed, traffic volume, roadway width, presence of parking, and other design elements.

### TRANSIT



Bus stops are pedestrian generators that require safe crossings, lighting, and stop amenities.

### AUTOMOBILES



Motorists require travel lanes sufficiently wide enough to facilitate through movement. Automobiles benefit from lighting along the street and turning radii that allows larger vehicles to complete turns at low speeds without mounting the curb.

### EMERGING



A range of new users have emerged in recent years, including operators of bikeshare bikes, electric scooters, TNC vehicles (Lyft/Uber). Design needs may include reserved zones for shared mobility parking and pick-up/drop-off areas for TNCs. In the coming years, autonomous vehicles (AVs) are anticipated to have significant impacts on street design needs. It is anticipated that automation will have a significant impact on the efficiency of parking, as well as the use of curb space for passenger loading/drop-offs. Vehicle lane widths can likely be narrowed, opening up opportunities for changes to standard designs.

Some uses are independent of a street's normal form and function, and require additional design consideration. A modal emphasis overlay identifies a special condition that can help to reconcile tradeoffs in corridors. Where space is limited, or where there are opportunities to repurpose extra space, the modal emphasis can indicate which elements should be prioritized.

## DESIGN MODIFICATIONS

### TRUCK ROUTES

Designated truck routes provide access from Interstate-5 and State Route 78 to commercial areas, the Village, business park areas, McClelland-Palomar Airport, and points beyond the city limits.

- Corner radius dimensions
- Land widths

### COASTAL STREETS

Coastal streets move people along the city's ocean waterfront and connect people to the beach, recreation, businesses and residences in close proximity to the waterfront. The street serves as a destination for people who seek to drive, walk and bicycle along the ocean waterfront.

- Speed management
- Enhanced bike & pedestrian crossings

### SCHOOL STREETS

School streets connect people to schools from nearby residential neighborhoods. Emphasis should be on providing safe pedestrian and bicycle access for students traveling to and from nearby schools. Vehicle speeds should be managed to support school uses (typically 25 MPH).

- Speed management
- Enhanced bike & pedestrian crossings

## STREET TYPOLOGIES

The typology of a street combines the elements of development context and transportation function to determine the best way to balance different modes of travel and preferences within limited street ROW. In the past, traditional street design processes began with automobile volume and speed as the main inputs, and designs centered on accommodating those expectations. This process inverts that approach by looking first at the building and roadway characteristics and then designing the facility for the desired automobile volume and speed. In this way, traffic volume and speed are outputs rather than inputs.

The Mobility Element defines 13 separate typologies within its Liveable Streets Guide. This guide provides a more nuanced set of typologies to effectively implement recommended strategies.

### ARTERIAL STREETS



- Primary vehicle routes through the city for both local and regional vehicle trips.
- Designed to safely move all modes of travel while efficiently moving vehicles and buses throughout the city.
- Bicycle lanes shall be provided and can be further enhanced or complemented by other facilities or off-street pathways
- Pedestrian facilities to be provided consistent with ADA requirements
- Traffic calming devices, such as curb extensions (bulbouts) or enhanced pedestrian crossings should be considered and evaluated for implementation

## CONNECTOR STREETS

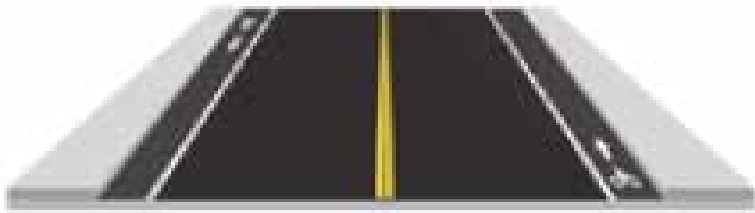

- Primary purpose is to move people throughout the Village/ City; providing access to businesses, residences, transit and recreation
- Designed to safely move all modes of travel while enhancing mobility for pedestrians and bicyclists
- Vehicle speeds should be managed to promote safe pedestrian and bicycle movement
- Promote pedestrian and bicycle connectivity through short block lengths
- Bicycle lanes should be provided
- Pedestrians should be accommodated on sidewalks adjacent to the travel way (minimum 5' wide sidewalk)
- Mid-block pedestrian crossings and traffic calming devices should be considered, but only at locations with high pedestrian activity levels or major destinations/attractions
- On-street parking may be provided

## NEIGHBORHOOD STREETS



- Primary purpose is to connect people to and through residential neighborhoods and local areas of the city
- Designed to safely move all modes of travel while enhancing mobility for pedestrians and bicyclists
- Vehicle speeds should be managed to promote safe pedestrian and bicycle movement
- Pedestrians should be accommodated on a sidewalk or soft surface trail (such as de-composed granite) unless those facilities are inconsistent with the existing desirable neighborhood character
- Bicycles can be accommodated with a bicycle lane or route if vehicle volumes and/or speeds necessitate; otherwise bicycles can share the street
- Bicycle boulevards can be considered
- Traffic calming measures should be considered when supported by the neighborhood or when warranted for safety reasons
- On-street parking should be considered



## CROSS SECTIONS

The elements that make up city streets, from sidewalks to travel lanes to transit stops, all vie for space within a limited right of way. Conceptual street 'zones' that can make up the right of way of the street include the following:

### CARTWAY ZONE

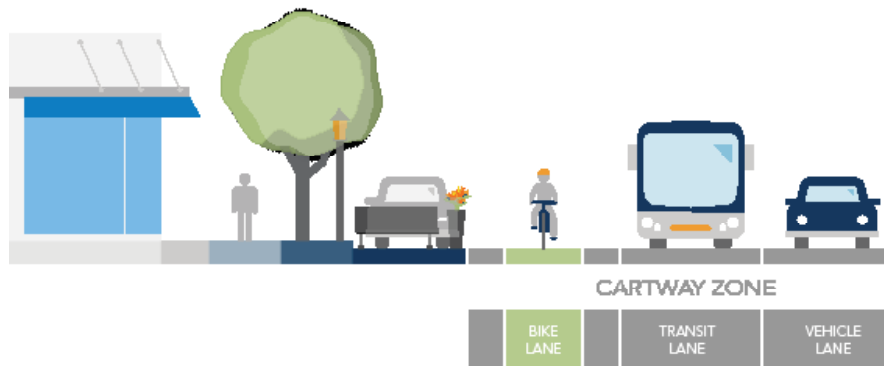

### ACCESS ZONE



The cartway, also known as vehicle zone, provides facilities for moving traffic. This includes space for motor vehicles, bicycles, and transit vehicles, which may be accommodated with dedicated or shared lanes. The cartway zone is present in every street typology.

The access zone includes elements directly adjacent to the curb on the street side, such as parking spaces and parklets. This zone serves stationary uses and makes up part of the buffer zone. The access zone may not be present in every street typology.

## AMENITY/CURB ZONE



The amenity/curb zone is located near the curb and provides space for amenities such as lighting, trash receptacles, seating, planters, trees, green infrastructure (e.g., bioswales), bicycle racks, bikeshare, and micromobility parking. This zone makes up part of the buffer zone, but may not be present in every street typology.

## BUFFER ZONE

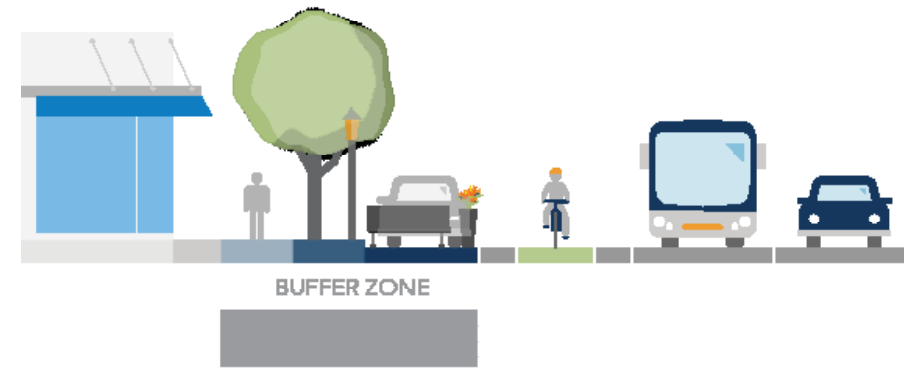

The buffer zone is a floating zone that exists as a combination of the amenity/curb zone and the access zone. The buffer zone will always be present, while the access zone or amenity/curb zone may not. Buffer zones separate pedestrians from vehicular traffic and create a more pedestrian-friendly space.

## CROSS SECTIONS CONT.

### WALK ZONE



The walk zone provides appropriate space for pedestrian traffic to travel without obstruction. It is a sidewalk space (or shared use path) clear of any other streetscape elements, and is present in every street typology, unless a design exception is made.

### FRONTAGE ZONE



The building frontage zone complements building uses by serving entryways, or providing space for sidewalk eating spaces. It is the space immediately adjacent to the building facade, and may be replaced by front yards in some street typologies.

# DRAFT



FRONTAGE ZONE

WALK ZONE

AMENITY CURB ZONE

ACCESS ZONE

CARTWAY ZONE

		FRONTAGE ZONE	WALK ZONE	AMENITY CURB ZONE	ACCESS ZONE		BIKE LANE		TRANSIT LANE	VEHICLE LANE
URBAN VILLAGE	NEIGHBORHOOD	0-2'	6'	4-6'	8'	N/A	N/A	N/A	N/A	10'
	COLLECTOR	2-4'	6'	6'	8'	3'	5'	3'	N/A	10'
	ARTERIAL	4-8'	10-12'	6'	8'	3'	5'	3'	11'	10'
SUBURBAN	NEIGHBORHOOD	N/A	5'	5'	8'	N/A	N/A	N/A	N/A	10'
	COLLECTOR	N/A	6'	5'	8'	3'	5'	3'	N/A	10'
	ARTERIAL	N/A	6'	5'	8'	3'	5'	3'	11'	11'

All widths here reflect recommended dimensions.

RAFT

# 3 WALK ZONE

## 3 WALK ZONE

The walk zone is the area dedicated to walking. Just like any travel lane, it should provide a logical path of travel. It must be ADA-compliant and clear of all obstructions. It should be straight and continuous. Attempts to create meandering walk zones usually fail because people want to walk in the most direct route possible. It should be sized to provide sufficient space for the expected pedestrian volumes, but not overly wide as to appear barren.





## SIDEWALK

A sidewalk is the paved portion of the right of way intended to provide for pedestrian through travel. Sidewalks are critical elements of property accessibility and should be designed to comfortably accommodate the pedestrian movement likely to occur in a given area. In low density residential areas this might be two strollers passing side-by-side. In the Village and Barrio area it might mean two people walking abreast with room for passing of one individual in the oncoming direction. The ideal dimension should be tailored to the density and ground floor use of the adjacent land.

### MORE INFORMATION

- NACTO: Urban Street Design Guide, 2013, pg 40
- City of San Diego: Street Design Manual, Pg. 2-3

### DESIGN POLICIES

- Sidewalks are required on every street except for roadways designated as Alternative Design Streets
- Each street type has a minimum clear walk zone of five feet that must be free of any obstructions (street furniture, utility poles, plantings, etc.)
- All street types also have a target clear walk dimension that should be a high priority in most circumstances

### MINIMUM PREFERRED DIMENSIONS

- A minimum of five feet clear walk zone should be achieved however per PROWAG R301.3., a width of four feet is the absolute minimum to meet ADA standards
- In constrained conditions, it is recommended that the width of other zones of the street be reduced before resorting to the minimum sidewalk width

## SIDEWALK

### MODAL PRIORITY



Sidewalk – Carlsbad



#### LOCATION

- SIDEWALK
- CURB
- MIDBLOCK
- CARTWAY
- INTERSECTION



#### STREET TYPE

- NEIGHBORHOOD
- COLLECTORS
- ARTERIALS



#### CONTEXT

- URBAN VILLAGE
- SUBURBAN



#### DRIVING SPEED

- LOW (20MPH OR LOWER)
- MEDIUM (25-35MPH)
- HIGH (30-45MPH)



#### TRAFFIC VOLUME

- LOW (LESS THAN 2K)
- MEDIUM (2K-20K)
- HIGH (20K-60K)
- VERY HIGH (MORE THAN 60K)



#### INTERSECTION CONTROL

- YIELD
- STOP
- SIGNAL





## SIDEWALK DINING

Sidewalk dining areas allow for restaurants and cafes to extend their business service area into the public right-of-way. Sidewalk dining should be encouraged within the Urban Village context and other areas where pedestrian and commercial activity is high. However, this use should never encroach into the clear walk zone.

### MORE INFORMATION

- City of Carlsbad: Carlsbad Village & Barrio Master Plan, 2018, Section 2.6.5, Right of Way Uses.

### DESIGN POLICIES

- Sidewalk dining should be restricted to the frontage(s) of the business it serves and should not encroach on the frontage of adjacent businesses. As per Section 2.6.5, Right of Way Uses, placement of sidewalk dining should satisfy the following requirements:
  - a. Approval of a Right-of-way Use Permit and other permits as determined necessary by the city engineer.
  - b. A signed Encroachment Agreement with the city if determined by the city engineer.

### MINIMUM PREFERRED DIMENSIONS

- Maintain a minimum five feet of sidewalk free from obstruction

## SIDEWALK DINING

### MODAL PRIORITY

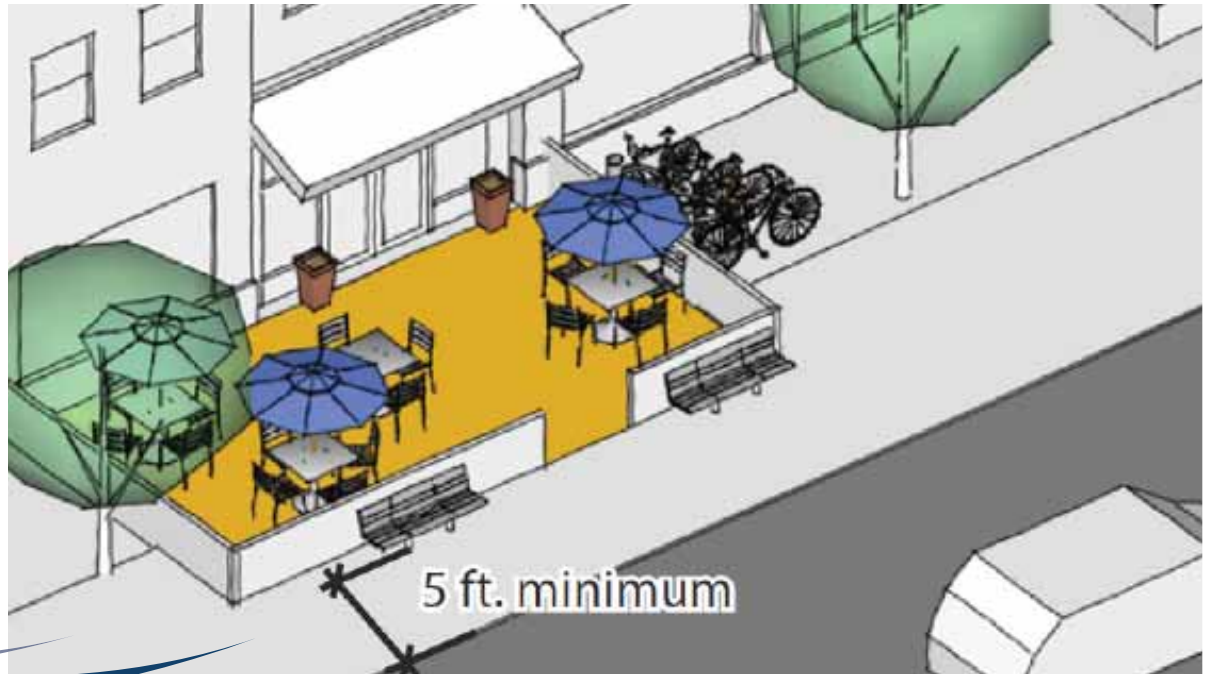

Sidewalk Dining – Preferred Placement



#### LOCATION

- SIDEWALK
- CURB
- MIDBLOCK
- CARTWAY
- INTERSECTION



#### STREET TYPE

- NEIGHBORHOOD
- COLLECTORS
- ARTERIALS



#### CONTEXT

- URBAN VILLAGE
- SUBURBAN



#### DRIVING SPEED

- LOW (20MPH OR LOWER)
- MEDIUM (25-35MPH)
- HIGH (30-45MPH)



#### TRAFFIC VOLUME

- LOW (LESS THAN 2K)
- MEDIUM (2K-20K)
- HIGH (20K-60K)
- VERY HIGH (MORE THAN 60K)



#### INTERSECTION CONTROL

- YIELD
- STOP
- SIGNAL

RAFT

# 4

## AMENITY ZONE



## 4 AMENITY ZONE

The Amenity Zone is located between the curb and sidewalk providing space for amenities to support multimodal activity in addition to standard street furniture and landscaping. Street furniture includes items such as parking meters, utility boxes, lamp posts, signs, bike racks, news racks, benches, and waste receptacles. This zone is often landscaped in residential neighborhoods and provides some level of separation between sidewalk and moving traffic.



## BUS PASSENGER WAITING AREA

Passenger waiting areas within the amenity zone provide space for enhancements at bus stops including seating, shelters, signage, wayfinding, lighting and waste bins.

### DESIGN POLICIES

- Bus stops should include a shelter whenever possible and should be designed so that the shelter and surrounding area are located in the amenity area separate from the clear walk zone.
- Additional space can be allocated to accommodate a shelter using bus bulbs on streets with parallel parking or other elements in the access zone.
- Shelters should be at least 10 feet from driveways.
- All bus zones have a bus sign post, regardless of the amenities being provided at a particular stop.
- A safe street crossing (see diagram on page 133) should be located no more than 400 feet from any bus stop.

### MORE INFORMATION

- MTS: Designing for Transit, 2018
- NACTO: Transit Street Design Guide
- NCTD Bus Stop Development Handbook

### MINIMUM PREFERRED DIMENSIONS

Preferred dimensions for amenity zone placement are approximately seven feet wide by 27 feet long to accommodate a five foot by 12 foot shelter and two foot curb clearance from the roof of the shelter. At heavily used stops, additional space may be required to provide a waiting area for passengers beyond the shelter area that does not interfere with the clear walk zone. A minimum unobstructed boarding area of five feet must be maintained parallel to the curb.

## BUS PASSENGER WAITING AREA

### MODAL PRIORITY

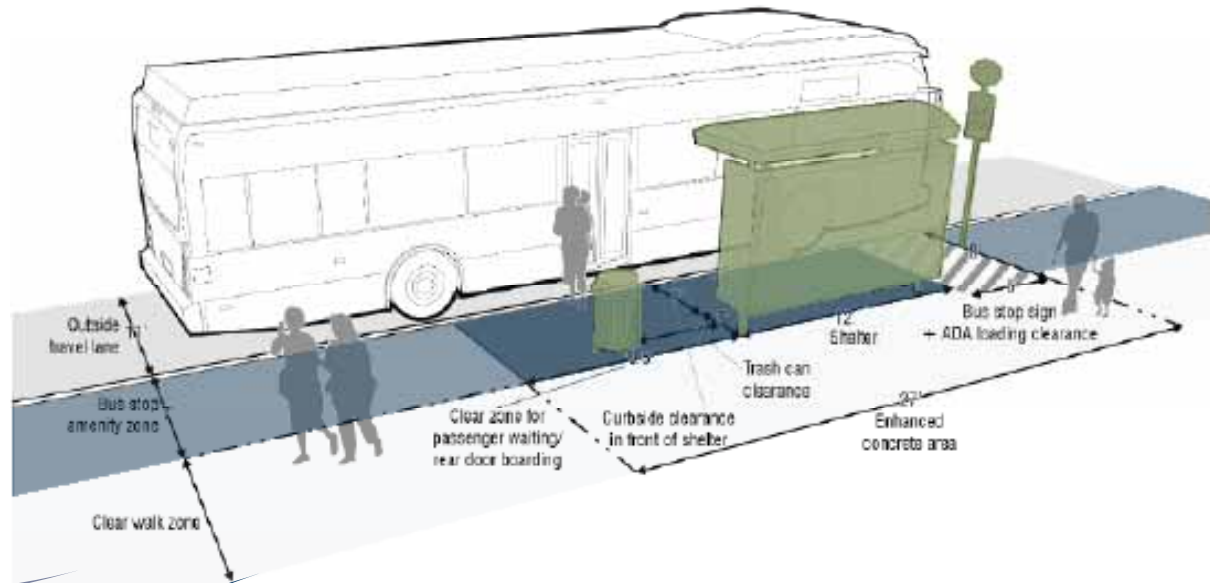

Bus Passenger Waiting Area - Preferred Design

 <h3>LOCATION</h3> <ul style="list-style-type: none"> <li>• SIDEWALK</li> <li>• CURB</li> <li>• MIDBLOCK</li> <li>• CARTWAY</li> <li>• INTERSECTION</li> </ul>	 <h3>STREET TYPE</h3> <ul style="list-style-type: none"> <li>• NEIGHBORHOOD</li> <li>• COLLECTORS</li> <li>• ARTERIALS</li> </ul>	 <h3>CONTEXT</h3> <ul style="list-style-type: none"> <li>• URBAN VILLAGE</li> <li>• SUBURBAN</li> </ul>	 <h3>DRIVING SPEED</h3> <ul style="list-style-type: none"> <li>• LOW (20MPH OR LOWER)</li> <li>• MEDIUM (25-35MPH)</li> <li>• HIGH (30-45MPH)</li> </ul>	 <h3>TRAFFIC VOLUME</h3> <ul style="list-style-type: none"> <li>• LOW (LESS THAN 2K)</li> <li>• MEDIUM (2K-20K)</li> <li>• HIGH (20K-60K)</li> <li>• VERY HIGH (MORE THAN 60K)</li> </ul>
--	---	---	--	---

## LANDSCAPING

Conventional stormwater management infrastructure is designed to convey the largest volume of water from a site as quickly as possible, collecting surface runoff in subsurface structures. Sustainable stormwater management, by contrast, views rainwater as an amenity, using it to improve urban ecology, microclimates, air quality, and the aesthetic quality of the public realm. Green street design utilizes landscaping, engineering, and urban design tools to mimic natural watershed capabilities. Treatments include bioretention, permeable pavement, planters, swales, infiltration, constructed wetlands, native vegetation, cisterns, and more. Each of these street design treatments increases the hydrological functionality of a street by increasing the absorption and filtration potential of a street, reducing runoff volumes into ocean-bound sewers. Commonly recommended green street treatments include the following:



### BIOSWALE

Bioswales are a type of infiltration planter that allow for stormwater to infiltrate through the soil and back into the groundwater table. Vegetated swales are typically long, narrow, landscaped depressed areas or planters that are designed to slope inward and are typically of shallow depth.



### PERVIOUS STRIPS

Pervious strips, like bioswales, slow and capture runoff and allow for some infiltration. They are typically long and narrow, running along the curb in the amenity zone. Pervious strips can be an inexpensive first step in stormwater management, but provide less capacity for infiltration than other elements.



## FLOW-THROUGH PLANTER

Flow-through planters have an impermeable base, but allow for runoff to be absorbed by the soil and vegetation then filtered into an underdrain system that captures water beyond the planter's capacity. Flow-through planters are appropriate in urban or high-density areas where infiltration into the water table is not possible.



## PERMEABLE SURFACES

Permeable surfaces include a set of pavement options that allow for stormwater to pass through the pavement material and into a subgrade level to be captured and infiltrated or routed into the storm drain network. Permeable surfaces can be used in sidewalks or on the roadway. Permeable surfaces include the following:

- Stone aggregate
- Permeable asphalt
- Permeable clay brick pavers
- Permeable interlocking concrete pavers
- Permeable concrete





## LANDSCAPING

### MODAL PRIORITY



### MORE INFORMATION

- County of San Diego: BMP Design Manual for Permanent Site Design, Storm Water Treatment and Hydromodification Management, 2019
- City of Philadelphia: Green Streets Design Manual, 2014
- NACTO: Urban Street Stormwater Guide, 2017

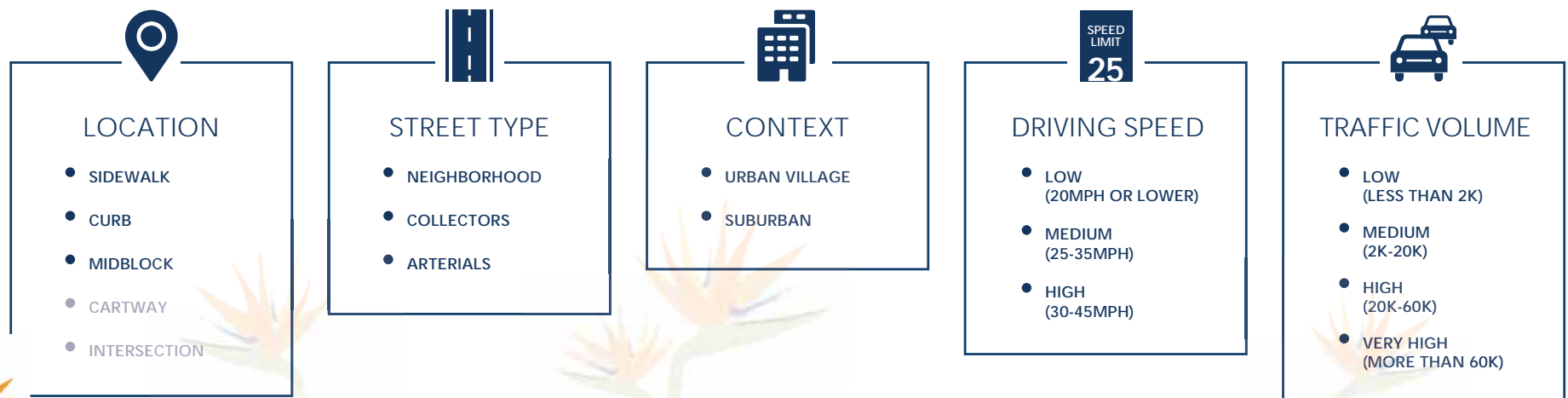

# DRAFT



DRAFT

5

ACCESS ZONE



## 5

### ACCESS ZONE

The access zone between the curb and travel lanes is a highly flexible area which can contain elements used by all modes. The primary purpose of the access zone is to accommodate the loading and unloading of passengers and goods. In lieu of on-street parking the access zone can be used to extend the realm of amenities through features like bike corrals and parklets.



## BUS LOADING ZONE

The bus loading zone, is the space in which a bus stops to pick up and drop off passengers. Streets should be designed so that transit vehicles do not have to weave in and out of the travel lane. Instead, transit vehicles should stop in lane, adjacent to a curb. In cases where the curb is separated from the travel lane by parked cars or other elements of the access zone, bus bulbs should be used to extend the curb out to the outside travel lane.

### MORE INFORMATION

- MTS: Designing for Transit, 2018
- NACTO: Transit Street Design Guide
- NCTD Bus Stop Development Handbook

### DESIGN POLICIES

- Far-side placement (after the intersection in the direction of travel) is preferred in order to ensure that passengers crossing the street walk behind the bus.
- The bus zone begins five feet from the radius return at the intersection.
- Bus stops with high levels of service (stops served by 10 or more vehicles per hour) need space to accommodate multiple vehicles simultaneously.

### MINIMUM PREFERRED DIMENSIONS

The length of the bus loading zone is dependent on the size of the vehicles serving that stop and the placement of the bus zone within the block.

## BUS LOADING ZONE

### MODAL PRIORITY



### BUS LOADING ZONE LENGTHS

LOCATION	LENGTH OF CURB FOR 40' BUS (FEET)	LENGTH OF CURB FOR 60' BUS (FEET)
Far-side	90	120
Near-side	100	170
Mid-block	120	140
For each additional vehicle	50	70





## BUS BULBS

Bus bulbs are a type of curb extension that extends a bus stop into the parking lane for the length of the stop. Bus bulbs are used to address constrained or insufficient sidewalk space for bus stops and/or on corridors where buses have difficulty merging back into travel lanes. Bus bulbs can improve transit travel time and reduce points of conflict between buses and other vehicles.

### DESIGN POLICIES

- Where on-street parking exists, bus bulbs may be installed to expand the bus stop waiting area and allow riders to board directly from the sidewalk.
- Bus bulbs are effective for rapid service but may not be appropriate for local routes or streets with one lane per direction.
- If the stop is located midblock, AASHTO notes that mid-block pedestrian crossings may be provided.

### MORE INFORMATION

- AASHTO: "A Policy on Geometric Design of Highways and Streets." In Green Book, 6th ed. (2011): 7-53.
- MTS: Designing for Transit, 2018
- NACTO: Transit Street Design Guide
- NCTD Bus Stop Development Handbook

### MINIMUM PREFERRED DIMENSIONS

Preferred depth of a bus bulb is six feet with a length that allows passengers to board and exit at all doors for the applicable type of bus.

## BUS BULBS

### MODAL PRIORITY



Bus Bulb – Portland, Oregon



#### LOCATION

- SIDEWALK
- CURB
- MIDBLOCK
- CARTWAY
- INTERSECTION



#### STREET TYPE

- NEIGHBORHOOD
- COLLECTORS
- ARTERIALS



#### CONTEXT

- URBAN VILLAGE
- SUBURBAN



#### DRIVING SPEED

- LOW (20MPH OR LOWER)
- MEDIUM (25-35MPH)
- HIGH (30-45MPH)



#### TRAFFIC VOLUME

- LOW (LESS THAN 2K)
- MEDIUM (2K-20K)
- HIGH (20K-60K)
- VERY HIGH (MORE THAN 60K)





## ON-STREET PARKING

On-street parking supports storefront retail and serves local residents and visitors for short-term parking needs. It also helps to visually narrow the street and slow vehicular traffic, as well as provide a buffer between the sidewalk and moving vehicles.<sup>1</sup> The provision of on-street parking should be evaluated based on competing needs for the space. Where space is available, back-in angled is preferred over standard parallel parking stalls as a speed management solution. Back-in angled parking provides drivers with a better view of other vehicles and bicyclists when exiting, positions motorists and passengers to enter and exit away from travel lanes, and is less challenging than parallel parking.

### MORE INFORMATION

- AASHTO: "A Policy on Geometric Design of Highways and Streets." In Green Book, 6th ed, 2011: 7-72.

### DESIGN POLICIES

- Ensure that a clear walk zone will not be impeded by the rear end of vehicles backed up to the curb

### MINIMUM PREFERRED DIMENSIONS

The target width for parallel on-street parking is eight feet, however the parking lane can be narrowed to 7 feet in constrained conditions, or for traffic calming purposes. Parking lanes that may serve other uses, such as loading zones or peak hour travel lanes, may require wider lane widths. The typical dimensions and layout of angled parking range from a 30 to 60 degree angle. The required width of an angled parking lane varies between 16 feet and 18.5 feet depending on the angle.

<sup>1</sup> Maintaining on-street parking should be prioritized where pedestrian activity is to be supported. "Eliminating curb parking can affect pedestrian safety and comfort, and reduce the livability of both commercial and residential districts." Source: American Association of State Highway Transportation Officials, A Policy on Geometric Design of Highways and Streets, 6th ed. 2011: 7-47.

## ON-STREET PARKING

### MODAL PRIORITY



Back-in Angled Parking – Hermosa Beach, California



#### LOCATION

- SIDEWALK
- CURB
- MIDBLOCK
- CARTWAY
- INTERSECTION



#### STREET TYPE

- NEIGHBORHOOD
- COLLECTORS
- ARTERIALS



#### CONTEXT

- URBAN VILLAGE
- SUBURBAN



#### DRIVING SPEED

- LOW (20MPH OR LOWER)
- MEDIUM (25-35MPH)
- HIGH (30-45MPH)



#### TRAFFIC VOLUME

- LOW (LESS THAN 2K)
- MEDIUM (2K-20K)
- HIGH (20K-60K)
- VERY HIGH (MORE THAN 60K)



## DRIVEWAYS

Driveways, as defined here, are curb cuts in sidewalks that provide vehicle access in and out of private property. Too many driveways, and poorly designed driveways, can interrupt the pedestrian environment and create conflict points with pedestrians.<sup>2</sup> Managing the number of driveways in all contexts can improve the pedestrian experience and overall sidewalk safety and can, in many cases, reduce automobile crashes associated with unorganized left turning movements.

### DESIGN POLICIES

- For streets where driveways are permitted, the apron should be placed within the curbside/amenity zone in order to maintain a level, ADA compliant Pedestrian Access Route.
- On-street parking should not be allowed within five feet of driveways. On higher speed streets, this distance may be increased to improve the visibility of pedestrians to turning vehicles.
- Appropriate markings should be used where vehicles must cross high-volume bicycle facilities to access driveways.
- Orient driveways 90 degrees to the street and use minimum radius where possible.

### MORE INFORMATION

- Federal Highway Administration: Achieving Multimodal Networks: Applying Design Flexibility and Reducing Conflicts, 2016

### MINIMUM PREFERRED DIMENSIONS

As per the City of Carlsbad Engineering Standards Volume 1, minimum driveway width for multi-family/commercial should be 24 feet and 12 feet for single-family residential. While the Engineering Standards indicate driveway width should not exceed 40 feet for commercial this dimension should be avoided as it will create a far less comfortable interface with pedestrians on the sidewalk.

<sup>2</sup> Poorly designed driveways can also contribute to congestion, as noted by AASHTO: "Conflicts and congestion occur at interfaces between public highways and private traffic-generating facilities when the functional transitions are inadequate. Examples are commercial driveways that connect directly from a relatively high-speed arterial to a parking aisle." American Association of State Highway Transportation Officials. "A Policy on Geometric Design of Highways and Streets." 6th ed. (2011): 1-2



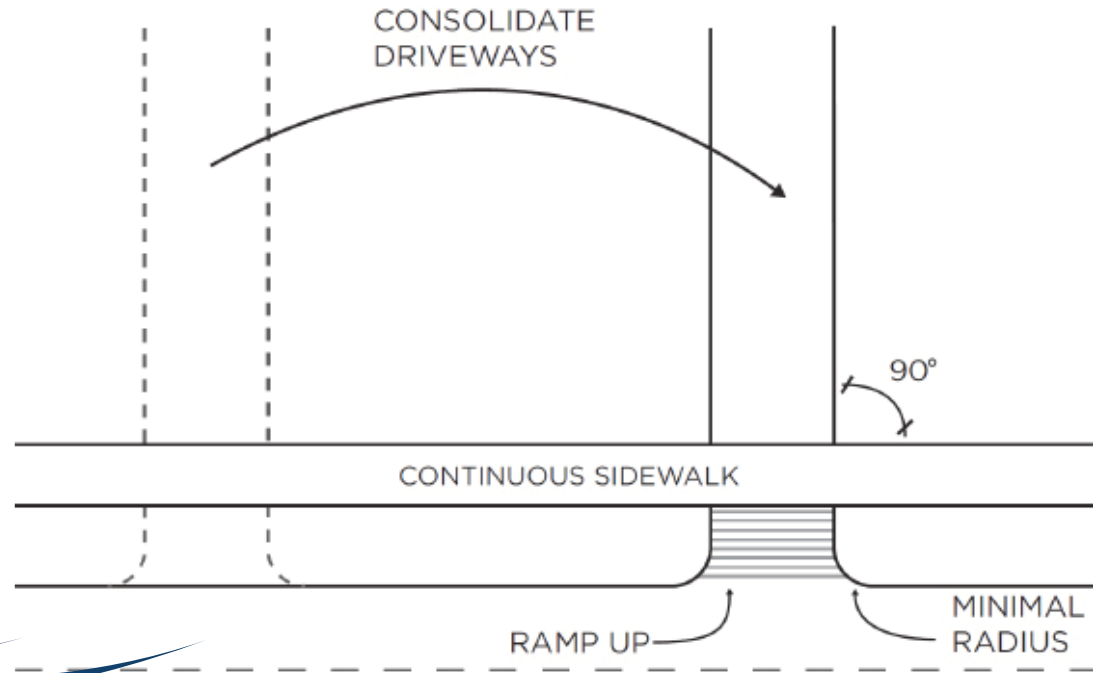

<sup>3</sup> The Village and Barrio Master Plan restricts driveway widths in the Urban Village Context to 20 feet.

## DRIVEWAYS

### MODAL PRIORITY



Driveway - Preferred Design

 <h3>LOCATION</h3> <ul style="list-style-type: none"> <li>• SIDEWALK</li> <li>• CURB</li> <li>• MIDBLOCK</li> <li>• CARTWAY</li> <li>• INTERSECTION</li> </ul>	 <h3>STREET TYPE</h3> <ul style="list-style-type: none"> <li>• NEIGHBORHOOD</li> <li>• COLLECTORS</li> <li>• ARTERIALS</li> </ul>	 <h3>CONTEXT</h3> <ul style="list-style-type: none"> <li>• URBAN VILLAGE</li> <li>• SUBURBAN</li> </ul>	 <h3>DRIVING SPEED</h3> <ul style="list-style-type: none"> <li>• LOW (20MPH OR LOWER)</li> <li>• MEDIUM (25-35MPH)</li> <li>• HIGH (30-45MPH)</li> </ul>	 <h3>TRAFFIC VOLUME</h3> <ul style="list-style-type: none"> <li>• LOW (LESS THAN 2K)</li> <li>• MEDIUM (2K-20K)</li> <li>• HIGH (20K-60K)</li> <li>• VERY HIGH (MORE THAN 60K)</li> </ul>
--	---	---	--	---



## LOADING ZONES

A loading zone is a dedicated curbside space intended for short duration parking to directly service nearby businesses or properties. Loading zones help promote a strong economy and a vibrant retail environment, particularly in downtown areas and neighborhood business districts. However, loading zones also take up space that could otherwise be used for general parking, pedestrians, or transit, and therefore should be well managed to optimize use. Alleys should be used for loading whenever possible.

### MORE INFORMATION

- AASHTO: "A Policy on Geometric Design of Highways and Streets." In Green Book, 6th ed, 2011: 7-47

### DESIGN POLICIES

- Loading zones are important, particularly in areas with commercial uses.
- Loading zones should be incorporated into on-street parking lanes or places on side streets.
- Loading during off-peak hours (typically early morning or late evening) should be encouraged.
- Loading zones must be clearly signed and marked to encourage proper use.

### MINIMUM PREFERRED DIMENSIONS

Loading zones should be a minimum of eight feet wide; however, nine feet is preferred.

## LOADING ZONES

### MODAL PRIORITY



Loading Zone – Seattle, Washington



## SHARED USE MOBILITY ZONES

Traditional loading zones or former on-street parking spaces can be repurposed to serve as pick-up and drop-off areas for taxis, ride-hailing services (TNCs) like Lyft and Uber, on-demand microtransit, and valet parking operations. The purpose of these zones is to reduce conflicts and mitigate traffic impacts from passenger pick-up and drop-offs.

### MORE INFORMATION

- Eno Center for Transportation: Shared-Use Mobility Zones: Fighting Congestion with a Home for Rideshare, 2015
- Eno Center for Transportation: Ahead of the Curb: The Case for Shared Use Mobility (SUM) Zones, 2017
- NACTO: Blueprint For Autonomous Urbanism, 2017
- ITE Curbside Management Practitioners Guide, 2018



### DESIGN POLICIES

- Shared Use Mobility (SUM) zones may be designated with signage, curb paint, and geo-fencing. Through geo-fencing integration with ride-hailing applications, each time a ride is requested, both drivers and passengers would be shown the location of the nearest SUM zone in which pick-ups and drop-offs can legally occur.
- Place SUM zones at the beginning or end of a block with on-street parking to allow for the most efficient use of the space given applicable vehicles will ingress and egress frequently.

### MINIMUM PREFERRED DIMENSIONS

SUM zones should be a minimum of eight feet wide with clear pedestrian access from the curb to the walk zone.

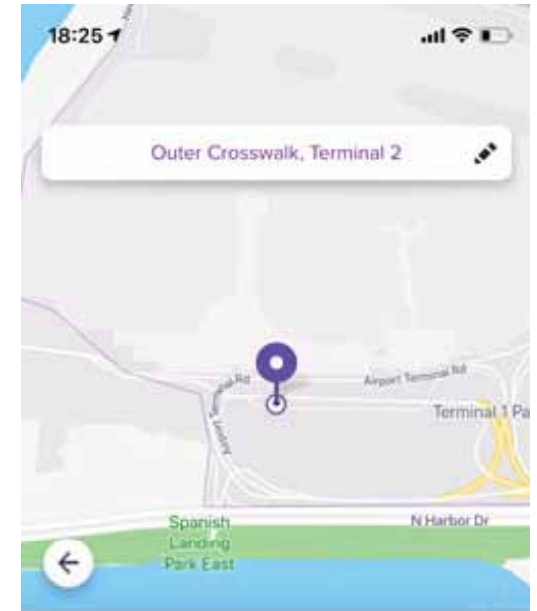

#### Set Pickup

Select a designated pickup by using the tumbler or dragging on the map.

Terminal 1

Terminal 2

Outer Crosswalk

Confirm

Designated TNC Pickup Zone – San Diego, CA

## SHARED USE MOBILITY ZONES

### MODAL PRIORITY

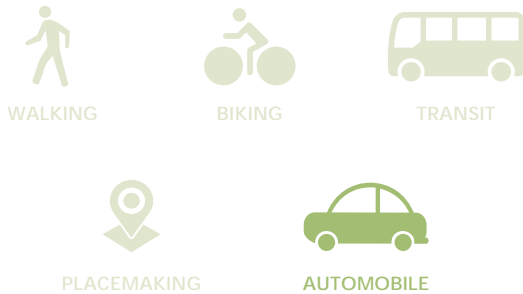

SOURCE: UNIVERSITY OF CALIFORNIA

SUM Zone – Los Angeles, California







## BIKE CORRALS

Bicycle corrals are on-street bicycle parking facilities that typically replace one or more vehicle parking spaces. Bike corrals can replace bicycle hoops, bike racks, freeing up sidewalk space for other uses such as additional pedestrian space or cafe dining. Bike corrals are an excellent solution for accommodating a large number of bicycles near specific activity areas and in areas with narrow sidewalks. Bike corrals can be installed at corners to “daylight” an intersection since bicycle parking has no effect on the visibility of pedestrians to moving vehicle traffic. Bike corrals have been shown to have a positive impact on business. Bike corrals can serve to move parked bicycles off of sidewalks to make additional room for pedestrians. In addition, because bike corrals are shorter than parked automobiles, they do not obstruct sightlines and can be used at corners without affecting the visibility of pedestrians to moving traffic.

### MORE INFORMATION

- Association of Pedestrian and Bicycle Professionals: Essentials for Bike Parking, 2015

### DESIGN POLICIES

- Bike corrals may be installed in the access zone in the place of one or more car parking spaces.
- Bike corrals should be oriented so that bikes may be parked on either side of the corral.
- The rack should support the bicycle frame in at least two places, allowing both the frame and the wheel to be locked and preventing bicycles from tipping over.
- The bike corral area should be demarcated using paint, bollards, or planters. Bollards or wheel stops should be installed on either end to separate parked cars from bicycles

### MINIMUM PREFERRED DIMENSIONS

Bike corrals should provide enough clearance for bicycles from the adjacent travel lane. Racks should be placed perpendicular to the curb where at least 8 feet is available and angled where a minimum 7 feet is available. Corrals should be spaced at least 3 feet apart to allow access to and from the sidewalk between corrals.

## BIKE CORRALS

### MODAL PRIORITY



Bike Corral – San Mateo, CA



### LOCATION

- SIDEWALK
- CURB
- MIDBLOCK
- CARTWAY
- INTERSECTION



### STREET TYPE

- NEIGHBORHOOD
- COLLECTORS
- ARTERIALS



### CONTEXT

- URBAN VILLAGE
- SUBURBAN



### DRIVING SPEED

- LOW (20MPH OR LOWER)
- MEDIUM (25-35MPH)
- HIGH (30-45MPH)



### TRAFFIC VOLUME

- LOW (LESS THAN 2K)
- MEDIUM (2K-20K)
- HIGH (20K-60K)
- VERY HIGH (MORE THAN 60K)



## PARKLET

Parklets are temporary or seasonal mini plazas located in former curbside parking spaces. Parklets provide an opportunity to turn underutilized spaces into attractive amenities for public interaction, art, dining, or other activated uses. Often the product of a partnership between the city and local businesses, residents, or neighborhood associations, these amenities have a distinctive design and accommodate unmet demand for public space, particularly on thriving retail streets or in commercial areas. Parklets convert curbside parking spaces into public seating platforms, with plantings, landscaping, and/or bike racks. Parklets are typically applied where narrow or congested sidewalks prevent the installation of traditional sidewalk dining.

### MORE INFORMATION

- AASHTO: Guide for the Planning, Design, and Operation of Pedestrian Facilities, 2004: Section 3.2.13: Ambience, Shade, and Other Sidewalk Enhancements

### DESIGN POLICIES

- Parklets should have a flush transition at the sidewalk and curb to permit easy access and avoid tripping hazards.
- Parklets should avoid corners and are best placed at least one parking space away from the intersection corner.
- Where installation of a parklet is under consideration for a site near an intersection, volumes of turning traffic, sightlines, visibility, and daylighting should be taken into account.
- Site selection should consider the level of utilization and nearby pedestrian volumes both during the day and at night. Seating may be integrated into the design itself or made possible with movable tables and chairs.

### MINIMUM PREFERRED DIMENSIONS

Parklets have a desired minimum width of six feet (or one foot less than the width of the parking lane).

## PARKLET

### MODAL PRIORITY



Parklet - Carlsbad



#### LOCATION

- SIDEWALK
- CURB
- MIDBLOCK
- CARTWAY
- INTERSECTION



#### STREET TYPE

- NEIGHBORHOOD
- COLLECTORS
- ARTERIALS



#### CONTEXT

- URBAN VILLAGE
- SUBURBAN



#### DRIVING SPEED

- LOW (20MPH OR LOWER)
- MEDIUM (25-35MPH)
- HIGH (30-45MPH)



#### TRAFFIC VOLUME

- LOW (LESS THAN 2K)
- MEDIUM (2K-20K)
- HIGH (20K-60K)
- VERY HIGH (MORE THAN 60K)



# 6 BICYCLE FACILITIES



## 6 BICYCLE FACILITIES

When the right-of-way is thoughtfully and clearly allocated so that all users have their right-sized piece of the street, the community realizes a range of benefits, from improved roadway safety for everyone to equitable access to jobs and opportunities.

A fully connected 8-80 network of bicycle priority streets connects many origins and destinations, without requiring the user to take significant out of direction routes or ride in places that do not suit their ability or skill level. The network is designed to provide infrastructure improvements, traffic calming measures, and strategically placed crossings to ensure the network is not broken up by gaps or barriers, such as high speed and high volume streets.

## FACILITY SELECTION GUIDANCE

An 8-80 network provides a system of streets that are safe and comfortable for people of all ages and abilities to ride bicycles. This is achieved by slowing down vehicle speeds, reducing traffic volumes, and/or increasing separation between vehicles and people on bicycles. There are many bikeway types, facilities, and roadway treatments that can be used to achieve these outcomes. The appropriate facility type is determined based on the intended users, and street characteristics.

### EXAMPLES OF EACH BIKEWAY TYPE

- CLASS I BIKEWAY
- SIDEPATH
- CLASS II BIKEWAY
- CLASS III BIKEWAY
- CLASS IV BIKEWAY
- BIKE BOULEVARDS

## CLASS I

Class I facilities – also known as multi-use paths or shared use paths – are paths for exclusive use by people on foot, on bicycles, or other mobility devices. They are separated from vehicle travel lanes, providing a more comfortable facility for a wide range of users. Class I facilities attract a wide range of users traveling at widely varied speeds – from people moving at a leisurely pace to cyclists traveling at higher speeds. Class I facilities are commonly located along beaches, rivers, streams, adjacent to railways or utility corridors, or within parks and open spaces.

### MORE INFORMATION

- FHWA: Small Town and Rural Multimodal Networks, Chapter 4: Physically Separated Facilities
- AASHTO: Guide for the Development of Bicycle Facilities, 2012: Chapter 5: Design of Shared Use Paths



### DESIGN POLICIES

- Minimize conflict between different user types through additional path width, signage, and design cues such as striping or separation.
- Shared use paths with a higher intensity of use should consider separation of users – separating pedestrians from bicyclists and/or separating oncoming directional travel.

## MINIMUM PREFERRED DIMENSIONS

Class I paths should have a minimum, unobstructed width of 10 feet; 12-16 feet is preferred. An additional shoulder area of two to five feet should be maintained on each side of the pathway; a minimum of two feet must be provided adjacent to obstructions such as bridge piers, large rocks, or utility poles. Two feet of lateral clearance is also required for post-mounted signage or other traffic control devices.

## MODAL PRIORITY



SOURCE: CITY OF CARLSBAD

Class I shared use path - Oceanside, California

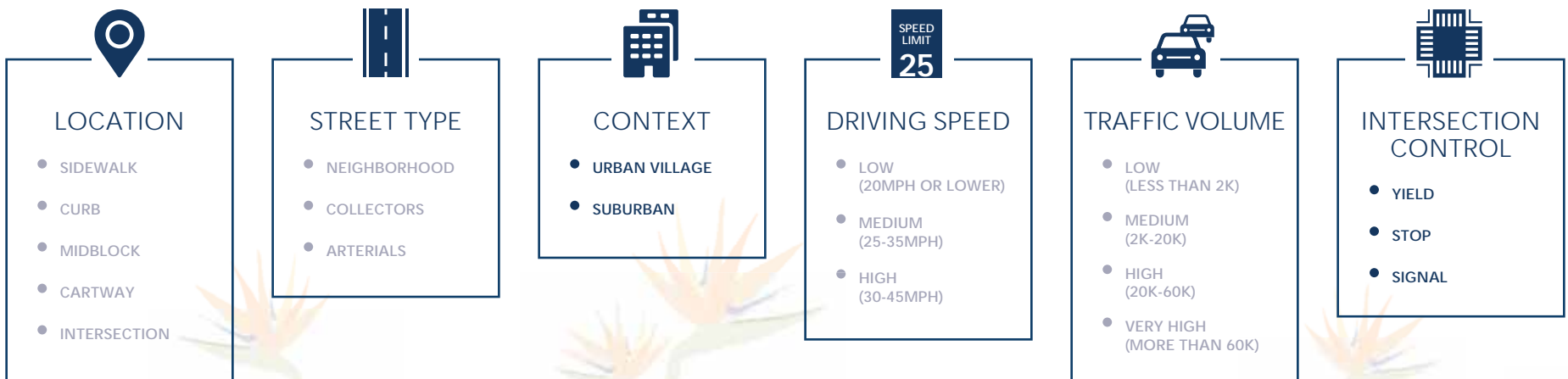





## SIDEPATH

Sidepaths are similar to Class I facilities, but are typically located parallel to a street, or within the right-of-way but separated from the roadway. Sidepaths tend to take the form of wide sidewalks, but are designed for both pedestrian and bicycle use, and may be paired with class II bike facilities (bike lanes) within the roadway.

### DESIGN POLICIES

- Instead of restricting contraflow travel, sidepaths should instead be designed to minimize potential conflicts for these users, and to increase visibility of contraflow travel by all corridor users.
- People walking should be separated from people biking if the total number of users is greater than 300 people in the peak hour, and if 30% or more of the users are pedestrians.
- Consolidate driveways to minimize the total number of conflict points and use signage to alert turning drivers to the presence of parallel or crossing bicycle traffic.
- Where the sidepath crosses a side street or driveway, implement speed reduction measures to reinforce the priority of movement by people walking and bicycling, including raised crossings, truck aprons, and prominent pavement markings. Signage along sidepaths may also be used to alert path users to watch for turning vehicles.
- At signalized intersections, signal timing may be adjusted to add an exclusive sidepath signal phase or leading interval.
- At side street crossings, sidepaths should be offset from the curb line of the parallel roadway by six feet to 24 feet to improve the visibility of bicyclists to turning motorists, and to allow motorists turning onto the primary roadway space to pull forward and yield to traffic in the primary roadway after yielding to sidepath users.

### MORE INFORMATION

- Michigan Department of Transportation: Sidepath Intersection & Crossing Treatment Guide, June 2018

## MINIMUM PREFERRED DIMENSIONS

Sidepaths should have a minimum, unobstructed width of 10 feet, and a minimum of 14 feet in urban areas. The minimum width should increase to 15 feet when pedestrians and bicycle are separated.



Sidepath - Indianapolis, IN

## MODAL PRIORITY

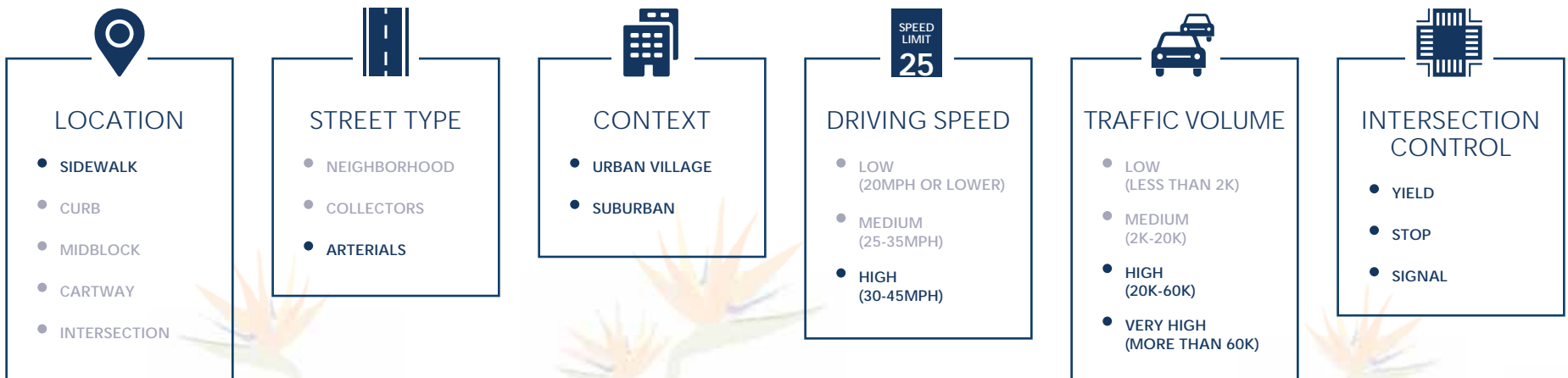

## CLASS II BIKEWAYS

Class II bikeways are dedicated bicycle lanes delineated by striping, signage and pavement markings. Conventional bike lanes are typically located immediately adjacent to a motor vehicle travel lane and usually located on the right-hand side of the street running in the same direction as motor vehicle traffic, but alternative configurations are possible.

Bike lanes alert motorists to the presence of a bike route, allow bicyclists to use the street with less interference from traffic, and increase comfort for cyclists and predictability for all roadway users. Providing bike lanes may reduce the incidence of cyclists riding on sidewalks.

Buffered bicycle lanes have a separation between the Class II bicycle lane and the travelway, increasing the distance between vehicles and cyclists by painting a buffer between the bike lane and parked or moving traffic. The additional buffer may also reduce the risk of cyclists getting hit by the doors of parked cars and allows cyclists to pass one another without entering the general traffic lane.



### DESIGN POLICIES

- Removing bike lanes in advance of intersections is not an 8-80 treatment, and should be avoided because it introduces a gap in the network.
- Avoid placing conventional bicycle lanes to the right of a right-turn lane or the left of a left-turn lane, unless a separate bicycle signal is provided.
- Use dotted/dashed lines to indicate areas of conventional bicycle lane/vehicle lane conflict, such as bicycle lane markings continuing through intersections or where right turning lanes cross bicycle lanes.
- For buffered bicycle lanes in retail areas, place the buffer adjacent to the parking lane if there is only room for a buffer on one side.
- Intersection treatments for buffered bicycle lanes may include conversion to conventional bicycle lanes, a cross-over through lane, or shared space, and are commonly paired with a bicycle box.

### MORE INFORMATION

- NACTO: Urban Bikeway Design Guide, 2nd Edition, 2014
- AASHTO: Guide for the Development of Bicycle Facilities, 2012: Section 4.5: Paved Shoulder; Section 4.6: Bicycle Lanes; Section 4.7: Bicycle Lane Markings and Signs
- FHWA: Separated Bike Lane Design Guide, 2015
- CA-Manual on Uniform Traffic Control Devices

## MINIMUM PREFERRED DIMENSIONS

Conventional bicycle lanes adjacent to the curb should be at least four feet wide, exclusive of the gutter pan. When the bicycle lane is between the travel lane and parking lane, the combined standard width of the bicycle lane and adjacent parking lane is at least 12 feet wide, though this design places bicyclists at risk of being hit by a door from a parked car. Two feet should be added to the lane width for bicycle lanes adjacent to guardrails, walls, or other vertical barriers. Buffered bicycle lanes should be at least five feet wide. The added buffer should be a minimum of two feet wide measured from the outside of the bicycle lane stripe (three feet is preferred). Where the bicycle lane is buffered by a parking lane, the buffer should be increased to three feet to allow for the opening of doors.



Class II Bike Lane - Carlsbad

## MODAL PRIORITY

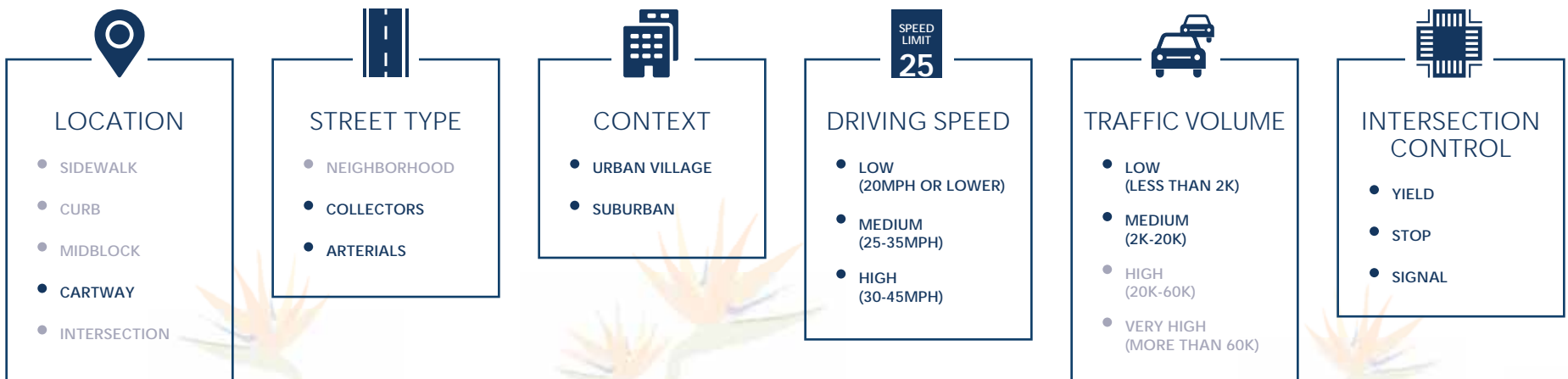



## CLASS III BIKEWAYS

Shared lane markings (sharrows) are pavement markings that reinforce that a lane is intended to be shared by motor vehicles and bicyclists. Shared lane markings alert motorists to expect bicyclists, remind motorists of the legitimacy of bicyclists to use the roadway, and orient bicyclists to the preferred line of travel outside the door zone. Shared lane markings do not create a dedicated bicycle facility, so some bicyclists will not be comfortable riding in travel lanes and relying on these markings to alert motorists. Shared lane markings are generally considered a minimalist bicycle accommodation and should be limited in use. On higher volume streets, these markings are an interim measure. As this facility would not be comfortable for all ages and abilities, it should not be illustrated on bikeway maps. Instead, bicyclists can be routed to other streets if dedicated bicycle facilities cannot be provided. Use of shared lane markings on streets with traffic volumes below 2,000 cars per day is appropriate for an 8-80 street.

### DESIGN POLICIES

- Shared lane markings are two chevron symbols positioned above a bicycle symbol. The chevrons should guide bicyclists out of the door zone and be positioned to point bicyclists in the direction of travel.
- When used on low volume streets, sharrows typically are provided as wayfinding, and should be supported with wayfinding signage indicating travel times, destinations, and key route decision points.

### MORE INFORMATION

- NACTO: Urban Bikeway Design Guide, 2nd Edition, 2014: Bikeway Signing and Marking: Shared Lane Markings
- AASHTO: Guide for the Development of Bicycle Facilities, 2012: Section 4.4, Marked Shared Lanes
- MUTCD, 2009: Section 9C.07, Shared Lane Marking

## MINIMUM PREFERRED DIMENSIONS

If the travel lane is adjacent to the curb, shared lane markings should be positioned at least four feet from the curb face. If the travel lane is adjacent to a parking lane, shared lane markings should be placed outside the door zone. Shared lane markings should be placed immediately after intersections and spaced at intervals not greater than 250 feet.



Class III Sharrow - Columbus, OH

## MODAL PRIORITY

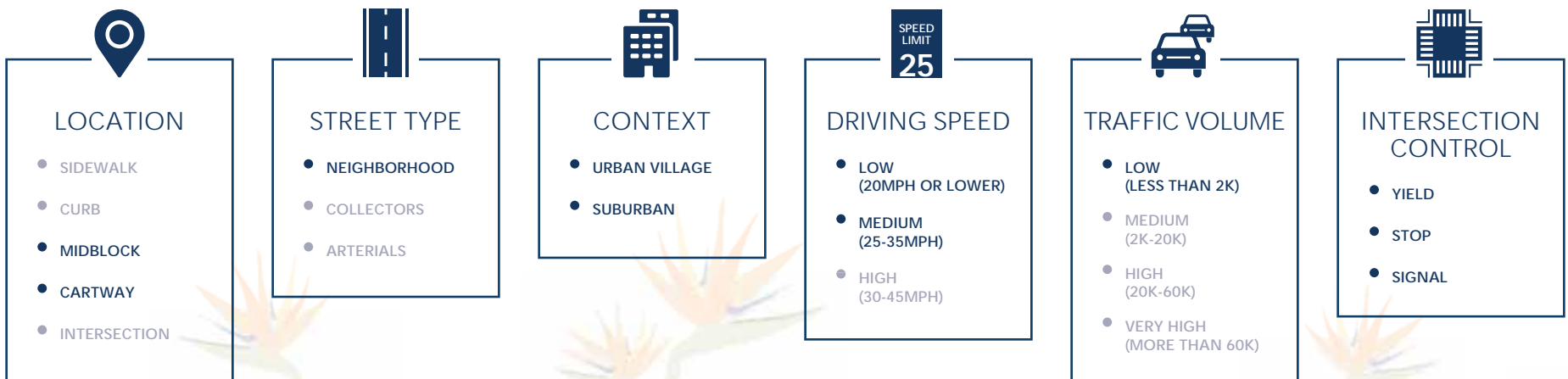



## CLASS IV BIKEWAYS

Class IV facilities – also known as separated bike lanes, separated bike lanes or cycle tracks – are on-street bicycle facilities with physical separation between the bikeway and the roadway, often by a curb, parked vehicles, planted median or flexible posts. Separated bike lanes reduce the risk of bicycle/ vehicle conflicts and have been shown to correlate positively with increased bicycling activity.

### DESIGN POLICIES

- Separated bicycle lanes require careful design at intersections to minimize conflicts with turning vehicles and to improve legibility, visibility, and predictability for all travelers. Use colors, yield lines, and “Yield to Bikes” signage to make it clear that the separated bicycle lane has priority over crossing traffic.
- Points of conflict should be clearly marked for both the cyclist and motorist. Bicycle through movements and motor vehicle turning movements should generally be in separate phases at intersections.
- Fully separated intersections provide the greatest level of physical separation and continuity of separated bicycle lanes, and can be combined with separate bicycle signal phases. Where separated intersections are not feasible, the protective barrier is can dropped on the intersection approach, becoming either a conventional bike lane or merging with turning car traffic.
- Separated bicycle lanes should be routed behind transit bus bulbs to eliminate conflicts between boarding or alighting passengers and through cyclists. Bicycle signals may be necessary for two-way separated bicycles lanes.

### MORE INFORMATION

- FHWA: Separated Bike Lane Planning and Design Guide, Chapter 5: Menu of Design Recommendations
- NACTO: Urban Bikeway Design Guide, Second Edition, 2014
- Massachusetts DOT: Separated Bike Lane Planning and Design Guide, 2015
- CA-Manual on Uniform Traffic Control Devices

## MINIMUM PREFERRED DIMENSIONS

Separated bicycle lanes should have a minimum width of five feet for a one-directional facility and eight feet for a two-way separated bicycle lane (10 feet is preferred), exclusive of the gutter. The added separation should be a minimum of 18 inches wide between separated bike lanes and travel lanes, and three feet wide if parked cars provide the separation.

Research has shown, over a 13 year period, that separated bike facilities are associated with a 44 percent decrease in cycling deaths and a 50 percent decrease in serious injuries (Marshall, 2017).



Class IV Separated Bike Lane - Long Beach, CA

## MODAL PRIORITY

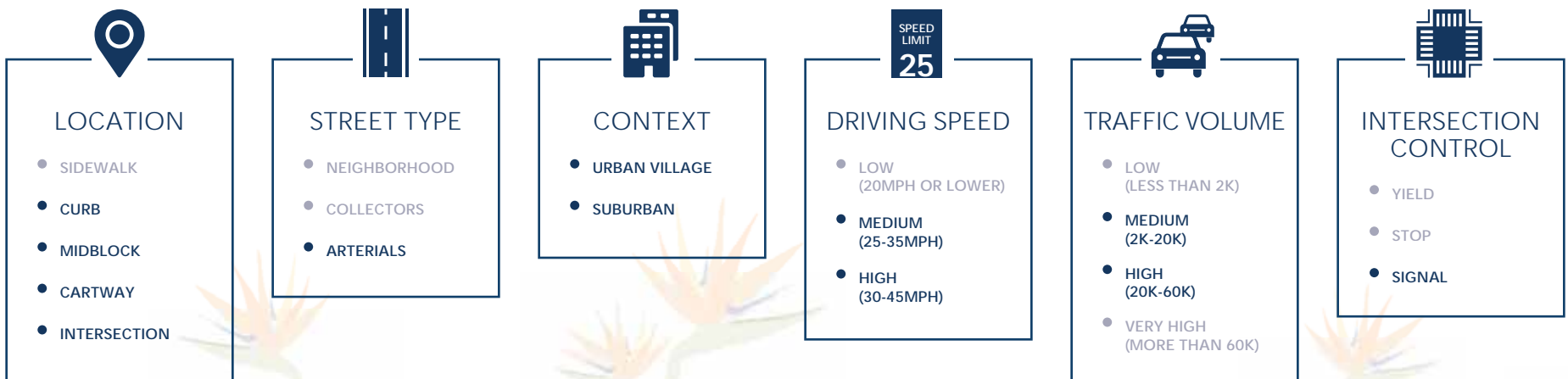





## BIKE BOULEVARDS

Bike boulevards are streets with low motorized traffic volumes and speeds, designed to give priority to through-bicycle travel and minimize through-vehicle traffic. These streets feature design elements such as signs and pavement markings, bulb-outs, chicanes, mini roundabouts, and diverters to manage vehicle volumes, “calm” traffic, and limit cut-through vehicle traffic. Bicycle boulevards can form the backbone of the community bicycle network and are often a lower-cost design treatment than many other bikeways described above.

### DESIGN POLICIES

- Bicycle boulevards may employ a range of speed and traffic calming treatments such as neckdowns, chicanes, speed humps or tables, diverters, and other such devices. These treatments reduce vehicle volumes and slow vehicle speeds to levels comparable with bicycle traffic in order to make the shared roadway environment more comfortable for people bicycling.
- Bicycle boulevard corridors may take circuitous routes to connect suitable low-stress neighborhood street segments, so clear signage and/or directional pavement markings oriented toward the bicyclist is required. Routes should run parallel and near to arterial streets to allow easy access to destinations along major corridors. Bike boulevards work best in a gridded and well-connected street network.
- Apply appropriate crossing and diversion treatments at major intersections. Bike boulevards are typically neighborhood residential streets, and the crossing of arterials and collectors may be unsignalized. Appropriate treatments to ease crossings of larger streets may include rapid flash beacons, pedestrian hybrid beacons, dashed conflict markings, curb extensions, and median refuge islands. Consider removing or flipping stop signs along the corridor to prioritize through bicycle traffic and create stop controls for cross traffic.

### MORE INFORMATION

- NACTO: Urban Bikeway Design Guide, Second Edition, 2014.
- California Manual on Uniform Traffic Control Devices, 2014. Chapters 9A, 9B, 9C.
- FHWA: Small Town and Rural Multimodal Networks, Chapter 2: Mixed Traffic Facilities

## MODAL PRIORITY



Bike Boulevard Treatments - Portland, OR

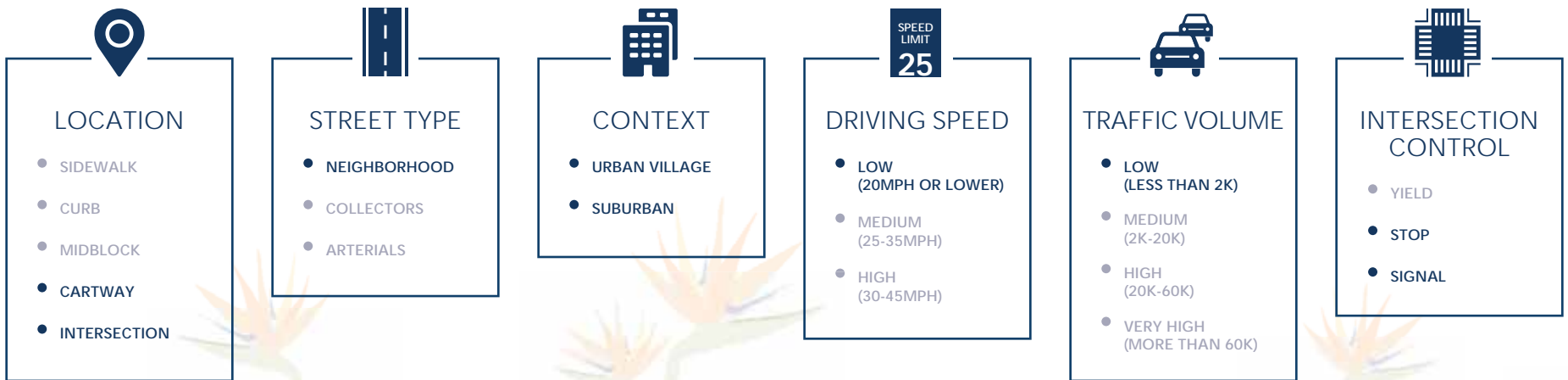

## SELECTING THE APPROPRIATE BIKEWAY TYPES

The physical and operational characteristics of a street help to determine which bicycle facility to construct for an all ages and abilities network. These include the number of motor vehicle lanes, amount of average daily motor vehicle traffic, existing uses of curb space, presence of transit service on the street, and the target motor vehicle speed. The figure to the right shows a simplified facility selection tool which accounts for motor vehicle speed and volume. Consult additional guidance before making decisions about facility type, considering what types of riders the bikeway is expected to support.

### MORE INFORMATION

- NACTO: Designing for All Ages and Abilities: Contextual Guidance for High-Comfort Bicycle Facilities, 2017

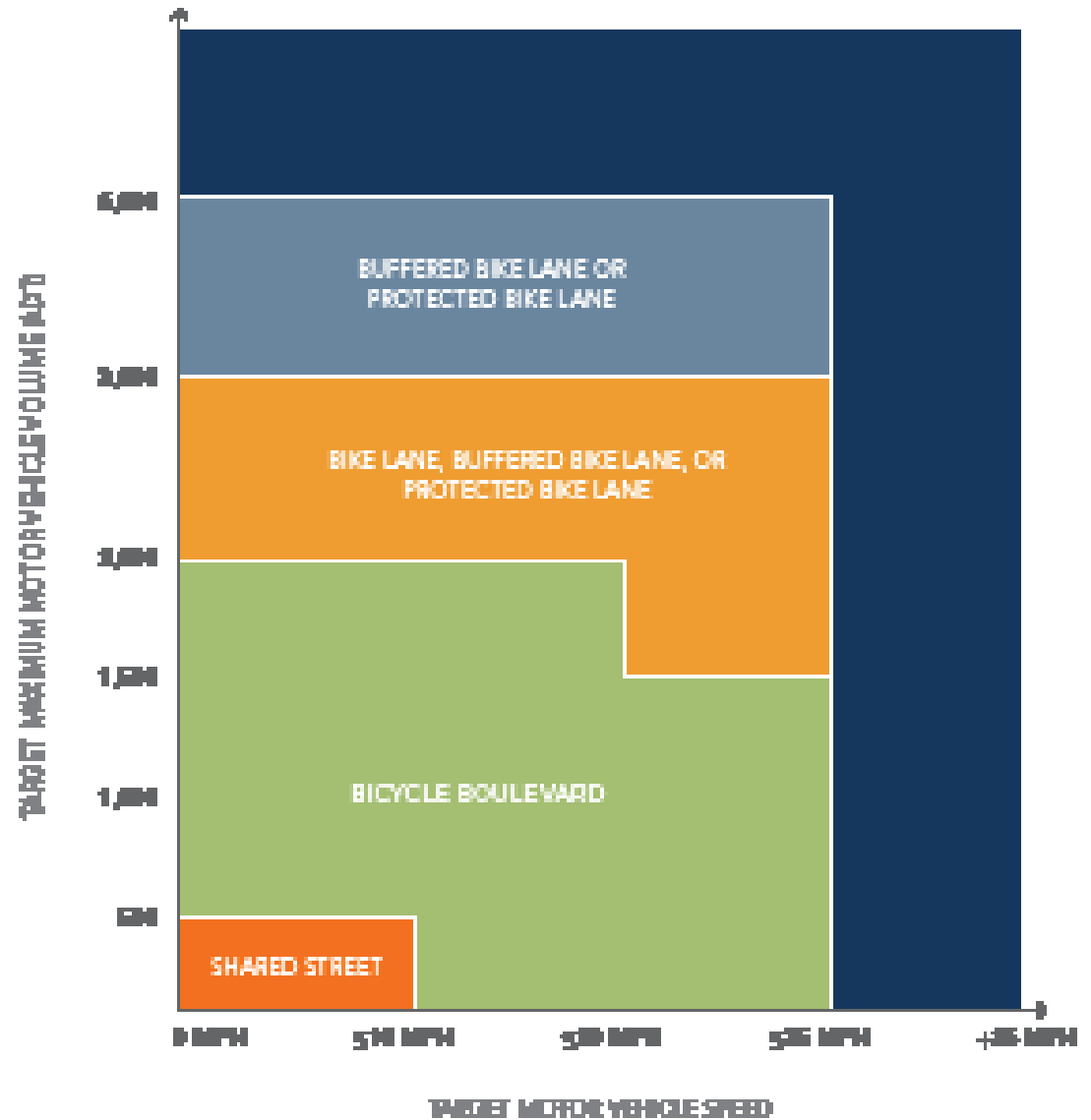

## DESIGN CONSIDERATIONS FOR BIKEWAY SEGMENTS

### FILLING IN BIKEWAY GAPS

When installing bicycle facilities, there may be locations or sections where maintaining the bikeway would require a tradeoff with parking or through motor vehicle lanes.

#### MORE INFORMATION

- MassDOT Separated Bike Lane Planning & Design Guide. Section 3.6. Determining Zone Widths in Constrained Corridors



Bicycle Facility Transition – Carlsbad

The Massachusetts DOT Separated Bike Lane Planning & Design Guide recommends the following as the order of priority to achieve the appropriate widths to accommodate bicycle facilities:

- Reduce number of travel lanes, narrow existing lanes, or adjust on-street parking
- Reduce width of sidewalk to levels appropriate for demand, and compliance with accessibility requirements
- Reduce the width of the sidewalk buffer/amenity zone. If pedestrian demand is low, consider combining the sidewalk and the bicycle facility into a sidepath
- Avoid narrowing or eliminating the buffer between the bicycle facility and the roadway. However, reductions in the bicycle facility width is appropriate near intersections if the width is transferred to the buffer
- Lastly, reduce the bicycle facility width to the minimum appropriate for the volume

Use of shared lane markings or other treatments may be appropriate if the length of the gap is short, and if vehicle speeds and volumes are low. However, if conditions are not suitable for bicyclists, they should instead be routed to other streets.

## GREEN PAINT

Bike lane edges are typically marked with solid white lines. In places of conflict, or where demarcation of the bike lane across an intersection or driveway would be beneficial, dotted lines may be used. Green paint was approved for use as a traffic control device that supplements bike lane markings in California in 2011, under Interim Approval IA-14. Studies reported to the FHWA Office of Transportation Operations reveal that green markings improve bicycle positioning, driver awareness, and feeling of safety. The treatment was approved to communicate to road users that a portion of the road has been set aside for exclusive or preferential use by people bicycling, and to enhance the conspicuity of a bike lane or bike lane extension.

### MORE INFORMATION

- NACTO Urban Bikeway Design Guide Chapter on Colored Bike Facilities



Green Paint – Carlsbad

Green is typically used to supplement bike lanes, bike lane extensions across intersections and driveways, and conflict zone markings, as described in the CA-MUTCD. Its optional use applies as supplements to both solid and dotted bike lane markings. It does not replace the other required markings such as a bike lane legend. Similarly, green colored pavement was approved for use as a supplement to bicycle boxes and their approach lane, via Interim Approval IA-18. The approval allows green paint to be used for all or part of the length between solid lines, and where bike lanes are dotted, the green may be continuous or matching the dotted pattern of the white lines. Therefore the typical application of solid or dashed is up to the local jurisdiction, and studies have not yet revealed whether there are user differences in comprehension between solid or dashed green bike lanes.

On the other hand a consistent use is recommended, such as using solid paint when the lane markings are solid, demarcating exclusive use by people biking, and dashed paint patterns when the lane markings are dotted, in places where conflicts should be expected because vehicles are required to cross the space to make turning movements.

## DRIVEWAY CONFLICTS

Access management strategies should be considered along bikeway segments, regardless of the type of bicycle facility provided, to minimize the number of points of conflict with turning and crossing vehicles. Access management involves the closure or consolidation of driveways to limit the locations where vehicles and bicycles would interact. This strategy is most relevant in high volume areas with many commercial or industrial driveways.

### MORE INFORMATION

- MassDOT Separated Bike Lane Planning & Design Guide. Section 4.3.5 Driveway Crossings



Driveway Conflict Treatment – Berkeley, California

Other strategies include using solid green paint to highlight the conflict zones for bicyclists and for drivers entering or exiting driveways, restricting parking directly adjacent to driveways to increase visibility, and minimizing the width of driveways to reduce vehicle speeds when turning.

When a setback sidepath or separated facility crosses a driveway, the crossings should be recessed to create space for the motorist to yield to approaching bicyclists without blocking other traffic. Raised crossings and refuge islands can also be incorporated to improve safety.



## GUTTERS

Bike facilities are often located along the roadway curb, and this can create challenges with water runoff, debris, and other maintenance issues. The bike lane width should always exclude the distance between the gutter seam and the curb, unless the gutter is extruded to 5 feet in width. Drainage grates should be outside the bike lane whenever feasible. Where drainage cannot be accommodated outside the bike lane, bicycle-friendly grates that provide cross-hatching to prevent tires from getting caught should be used.

### MORE INFORMATION

- MassDOT Separated Bike Lane Planning & Design Guide. Section 3.8 Drainage and Stormwater Management
- NACTO Urban Bikeway Design Guide. Green Infrastructure.
- NACTO Urban Street Stormwater Guide

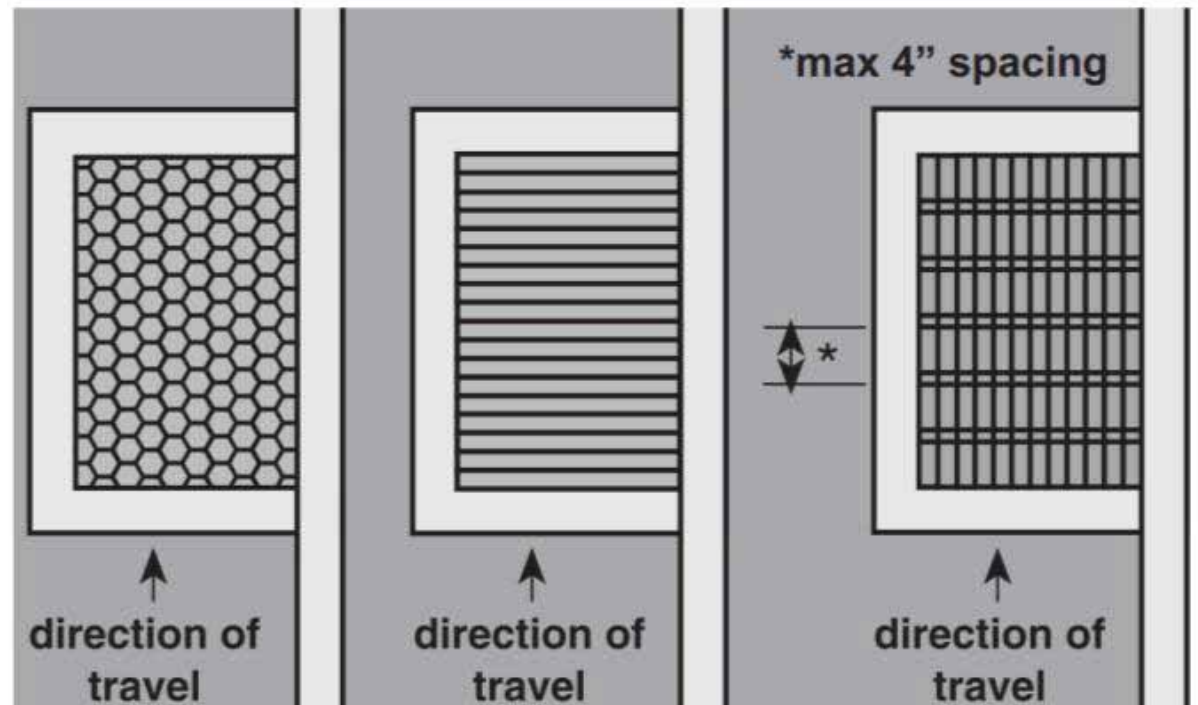

SOURCE: FHWA - BIKESAFE

Bicycle-friendly Grates

A bike facility adjacent to the curb requires considerations for drainage and to avoid ponding and debris accumulation. New catch basins or connections to existing drainage may be required, especially with separated or raised bike lanes. Additional catch basins or curb cuts for water may be needed as projected bicycle volumes increase.

## DESIGN CONSIDERATIONS FOR INTERSECTIONS

Accommodating bicycle facilities at and across intersections may require additional considerations or treatments. The following are potential measures to support connectivity and safety through intersections.

### MORE INFORMATION

- NACTO Urban Bikeway Design Guide. Bicycle Signals.
- MassDOT Separated Bike Lane Planning & Design Guide. Section 6.4 Bicycle Detection.
- CA-Manual on Uniform Traffic Control Devices

## BIKE DETECTION

Bicycle detection is required at traffic signals in California. Actuation can occur automatically (in-pavement detectors, microwave, or by video), or with push-buttons. Automatic actuation should always be adjusted to detect bicycles. In-pavement detectors should be located in positions where bicyclists are intended to travel or wait so that the actuation is properly triggered.

Signage and stencil markings should always be provided to guide bicyclists on how to actuate the signal (such as where to stand or what button to push).

When a separated or separated bike lane is provided, the bicycle actuation may trigger a separate phase. If appropriate for the location, a no-turn-on-red restriction sign may be activated along with the bicycle phase.



Bicycle Detection Signage – Santa Monica, California



## INTERSECTION TREATMENTS

The design of intersections is important to reduce conflicts, increase visibility and ensure awareness between various modes. Signage, medians, signals and pavement marking are all various ways to increase safety at intersections.

### MORE INFORMATION

- Caltrans Complete Intersections: Guide to Reconstructing Intersections and Interchanges for Bicyclists and Pedestrians
- NACTO Urban Bikeway Design Guide. Intersections.
- MassDOT Separated Bike Lane Planning & Design Guide. Section 4.4. Pavement Markings and Traffic Sign Guidance.



Bicycle Intersection Treatment – Minneapolis, Minnesota

Intersection crossing markings delineate the intended path of bicyclists and provide guidance on the direct path through the intersection, especially if the path of travel is offset. Additionally, the markings improve awareness of bicyclists by drivers to avoid conflicts upon turning, and encourage motorist yielding behavior. Intersection crossing markings can be paired with yield lines, warning signs and other elements to increase driver yielding behavior and visibility of the crossing.

## BIKE BOXES

A bike box is a designated area on the approach to a signalized intersection, intended to provide bicyclists a visible place to wait in front of stopped vehicles during the red signal phase for the purpose of providing a head start at the onset of the green phase. Bike boxes make cyclists more visible to motorists and transit operators by positioning them at the head of a queue during a stop cycle. On corridors of high bicycle activity, bike boxes cluster multiple cyclists and enable them to progress forward at the onset of the green signal cycle,



Bike Box – Portland, Oregon

### MORE INFORMATION

- MassDOT Separated Bike Lane Planning & Design Guide. Section 4.4.10. Two-Stage Turn Queue Box
- NACTO Urban Bikeway Design Guide. Bike Boxes.
- NACTO Urban Bikeway Design Guide. Two-Stage Turn Queue Boxes.

reducing conflicts with right turning vehicles.

Bike boxes are typically installed at signalized intersections with high volumes of bicycles and/or motor vehicles, especially those with frequent motorist right turns; where there may be right- or left-turning conflicts between bicyclists and motorists; and in places where the dominant motor vehicle traffic flows right and bicycle traffic continues through, such as a Y intersection or access ramp.

## SEPARATED INTERSECTIONS

Separated intersections provide an opportunity to emphasize the priority and safety of people biking. Separated intersections use raised curb sections at the corners to separate and protect waiting bicycles and pedestrians from motor vehicle traffic. The separated intersection continues the physical separation of separated bike lanes, positioning bicyclists prominently ahead of right-turn conflicts and creating safe, simple bicyclist movement through intersections. This can be achieved without moving existing curbs, with modifications making the intersection more compact and organized.

The separated intersection enables safe, two-stage bicycle turn movements aligned with concurrent traffic flow. Bicyclists are better placed in the sightline of turning vehicles, decreasing sideswipe and right-hook conflicts. Separated intersections should be considered wherever bikeways meet one another, but can also be applied to individual bikeways.

### MORE INFORMATION

- MassDOT Separated Bike Lane Planning & Design Guide, 2015. Chapter 4, Intersection Design.

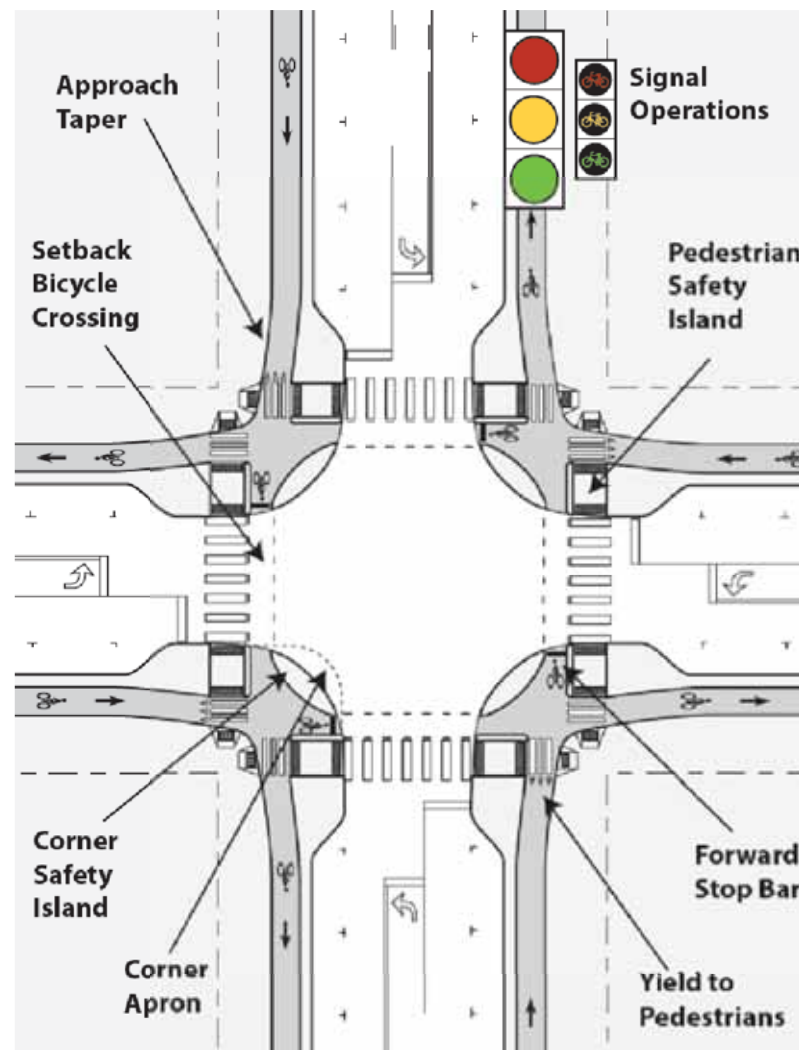

Separated Intersection Design

## SEPARATED ROUNDABOUT

The separated roundabout applies elements of the separated intersection to a roundabout intersection design. Separated roundabouts maintain physical separation of bicycle facilities through the intersection while incorporating the key benefits of roundabout design for all street users: efficiency of movement; reducing speeds at points of conflict; and a dramatic reduction in the most serious types of collisions through the near-elimination of head-on and right-angle conflicts.

### MORE INFORMATION

- MassDOT Separated Bike Lane Planning & Design Guide, 2015.
- CROW Design Manual for Bicycle Traffic (Netherlands), 2017.



SOURCE: MASSDOT

Separated Roundabout

Separated roundabouts are discouraged as an intersection treatment for two-way separated bicycle facilities, because motorists are not expecting bicycle riders moving both counterclockwise through the roundabout (with the direction of traffic) and clockwise (against the flow of traffic).

Shared lane markings through roundabouts are not an appropriate 8-80 treatment for low stress bikeways continuing through either single-lane or multi-lane roundabouts.

The Caltrans Highway Design Manual also provides guidance on roundabout design that directs bicyclists away from the roadway bike lane at the roundabout and onto a shared use path with pedestrians.

## ADDED RIGHT TURN LANES AT INTERSECTIONS

At some intersections, a turn lane may be added to provide capacity for vehicles to make a right turn. When a bicycle facility and turn lane are both present, there is a risk of collisions between through-travelling bicycles and vehicles that turn right. Motorists should be encouraged to yield to people on bikes, even if a bike lane cannot be maintained. This is typically accomplished with dashed lines that indicate the bike lane travel path, with symbols or signage indicating the dashed lane is for bicycles, and additional signage indicating drivers must yield to bikes. Additional treatments such as colored pavement may also be used.

### MORE INFORMATION

- MUTCD, 2009: Section 9C.04, Markings For Bicycle Lanes
- NACTO Urban Bikeway Design Guide. Intersections.

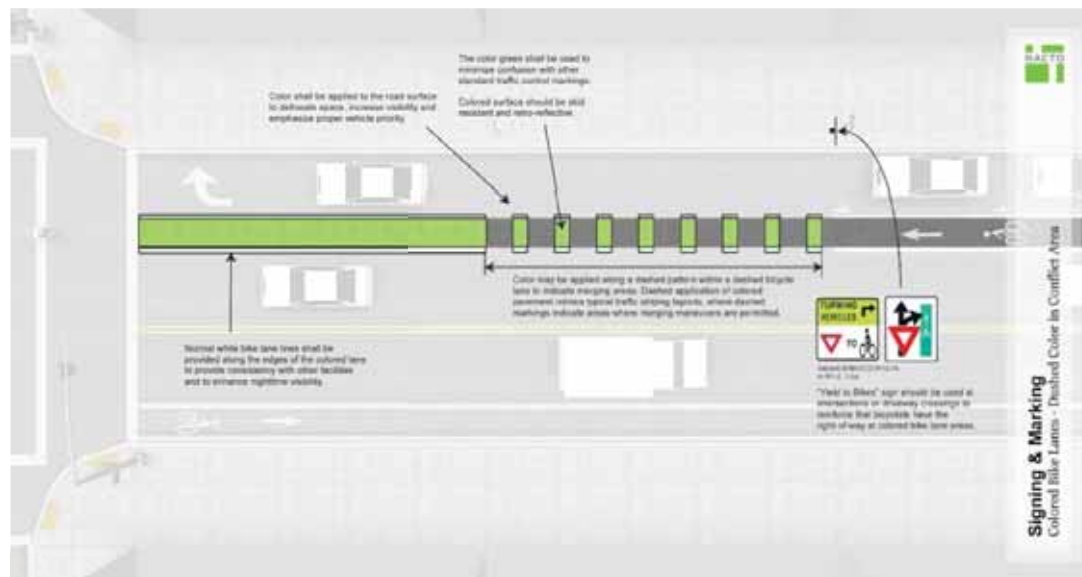

SOURCE: NACTO

Bikeway Design

The length of the transition zone for vehicles to enter the right turn lane should be minimized to reduce the chance for conflict.

Where there is insufficient width to include a right-turn lane and a bike lane, it may be appropriate to develop a combined bike lane/turn lane. This involves striping a bike lane or including a shared lane marking within a right turn lane to indicate the mixing zone of both modes.

These treatments are heavily dependent upon the visibility of markings, and cities should ensure maintenance is a top priority to make sure the markings continue to be effective.

## MIDBLOCK TRAIL CROSSINGS

If roadway or trail traffic conditions do not warrant a grade-separated crossing of the roadway, a number of considerations apply to the design of trail crossings at mid-block locations. In general, the same principles that apply to design of pedestrian crossing facilities also apply to bikeway crossings. Midblock trail crossings should intersect the roadway as close to a right angle as practical to improve sightlines for all trail and roadway users. Stop or yield signs should be considered for trail users as needed at approaches to roadway crossings.



Midblock Trail Crossing – Columbus, Ohio

### MORE INFORMATION

- FHWA: Small Town and Rural Multimodal Networks, Chapter 4: Physically Separated Facilities
- AASHTO: Guide for the Development of Bicycle Facilities, 2012: 5.3 Shared Use Path-Roadway Intersection Design
- California Manual on Uniform Traffic Control Devices, 2014: Part 9: Traffic Control for Bicycle Facilities

The most basic shared use path crossing involves a marked high visibility crosswalk with signs and other markings to slow or stop traffic. This may be an appropriate crossing treatment for trail crossings of local streets. Across roadways with higher speeds, higher traffic volumes, or three or more travel lanes, median islands or pedestrian hybrid beacons can be used to simplify the crossing.

DRAFT

# 7 CARTWAY



## 7

### CARTWAY

The cartway refers to the area primarily reserved for travel lanes and the throughput of motorized vehicles (automobiles, buses, trucks). On smaller roads or shared streets it is also the primary location for bicycling. The width of a travel lane is a critical dimension that impacts many different aspects of the street, including: vehicle speeds, pedestrian crossing distances, signal cycles, and the total amount of impervious surface. In most cases, the minimum acceptable lane width should be used in street design. This minimum dimension may vary depending on the street typology, and the most frequent vehicle using the lane. Lane width is the dimension of a travel lane, as measured from the center of the lane marking to the center of the next lane or to the face of the curb. The proper dimensions for Carlsbad are shown in Chapter 2 table on page 19.



## SPEED MANAGEMENT PRINCIPLES

### SPEED, EXPOSURE, AND PREDICTABILITY

Vehicle Speed is a significant determinant of crash severity, especially between modes. The operating speed along a street should reflect not on the roadway but also the context. Reducing vehicle speeds opens up a range of design options that allows a street to function consistently within the contextual uses outlined in the Carlsbad Mobility Element. Minimizing exposure risk, the time that users are exposed to conflicting movements, creates safer streets. Narrower streets, smaller intersections, leading pedestrian intervals, separated bicycle facilities all achieve this. Being able to predict what others will do, where they will go and when makes a street safer. Streets with consistent speed profiles, intersections with predictable signal operations, and low-speed streets where drivers make eye contact with each other, cyclists and pedestrians are generally safer streets.



## SPEED LIMITS, DESIGN SPEED AND OPERATING SPEED

While all drivers understand that streets have speed limits, most do not understand how those limits are determined. The actual practices and laws behind setting these speed limits are driven by assumptions that the majority of drivers are prudent and reasonable and that speed limits cannot be set arbitrarily low, as this would create violators of the majority of drivers and not command respect of the public.

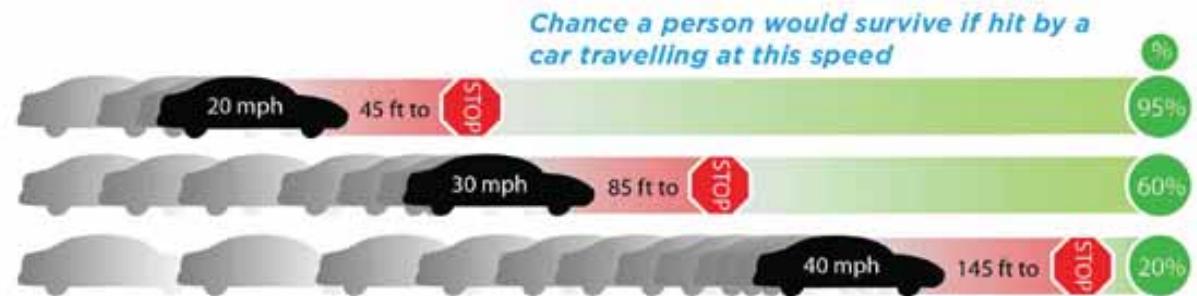

### *Tunnel Vision: as speed increases, peripheral vision decreases.*

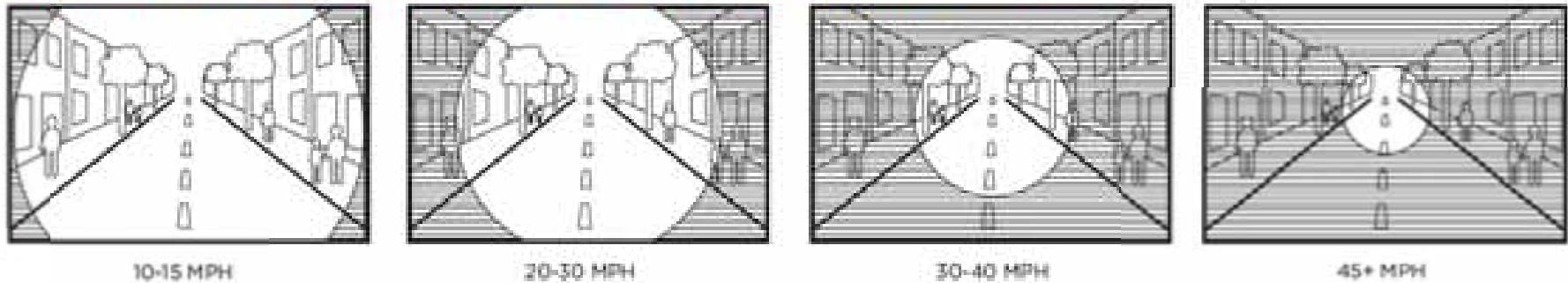

Vehicle Speed and Injuries

## STATE LAW AND LOCAL CONTROL

While Caltrans sets speeds on State highways, local jurisdictions are responsible for the speed limits on their facilities. This means that cities may set and post speeds at any value they wish – however, if those speed limits don't comply with State statutory methods then any police action resulting from speeding will be inadmissible in court. This not only means that speeding tickets written on non-complying streets would be invalid, but any other illegal activity discovered on such a stop would be dismissed as well. This represents a strong incentive for many communities to keep their

speed limits compliant with State law.

California law requires that speed limits be set based on the "prevailing speed" as determined by a speed survey. The survey measures driving speeds to determine the speed of cars in the 85th percentile of all drivers on the street (this percentile is arbitrary, but is codified in the law). The legally enforceable speed limit is set within 5mph of the 85th percentile.

The law does allow that if an engineering safety survey were to show a need for a lower speed limit than that 85 percent rule would call for, then the results could be 5mph. This reduction must be justified on the formally on

the traffic study and can most commonly be justified by "conditions not readily apparent" to motorists. School zones are exempt from the speed survey calculations and may be set at 25 mph without a speed survey.

In order to be compliant with the statute and to enforce speed limits, cities are required to regularly update their speed limits. The state does have statutory prima facie (on the face of it) speed limits established by the Vehicle Code that include a 15 mph limit for alleys, blind intersections, and blind railroad crossings. A 25 mph limit applies to business and residential districts, school zones, playgrounds in parks, and senior centers.

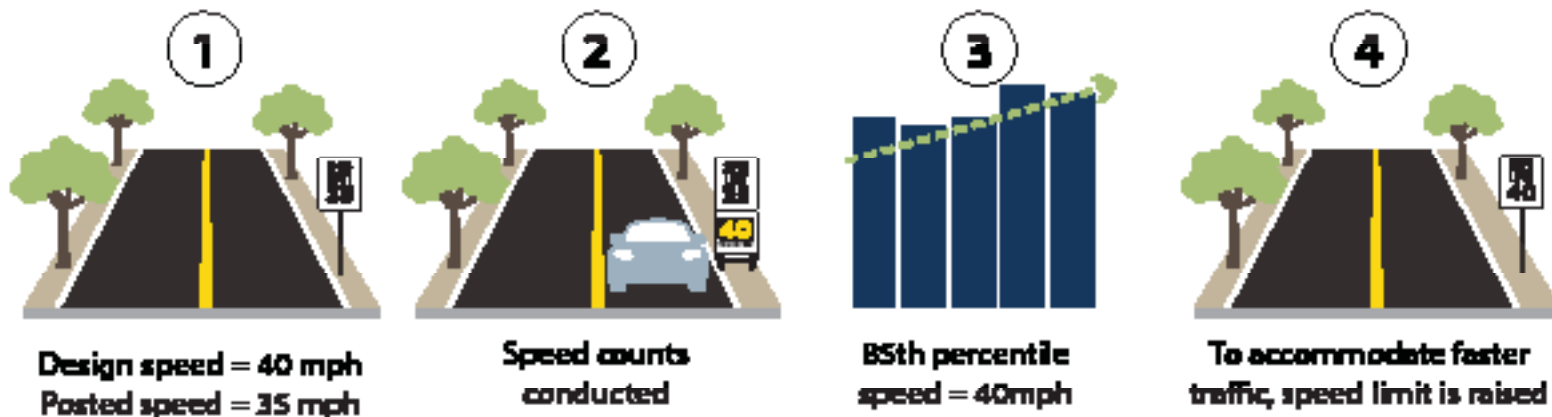

## BEST PRACTICES

This system is frustrating for many California communities as well as other communities around the country in states with similar laws. The key for most cities in dealing with the limitations is recognizing that the speed limit signs are not the primary factor determining driving speeds (and safety) – it is the actual design of the street. The best practice in these communities is to determine a set of criteria that will support physical changes that, when implemented, should affect driving speed decisions.

Whether we realize it or not, much of our behavior on a street is influenced by the environmental cues we get from the design of the street itself. On a very wide road with few buildings, trees, or activities along the street edge, a driver can easily underestimate the speed they are traveling and inadvertently exceed the speed limit. On such streets, the driver's attention focuses on points further ahead and their awareness of peripheral vision diminishes. On a narrow street with buildings and trees providing a sense of enclosure and many active uses along the street edge, drivers have a better sense of the speed they are traveling relative to other users on the street. The slower speed, in turn, increases their perception of activities on the periphery. Stated simply, wide, flat

roads make people feel like they should drive faster, while they intuitively sense that slower speeds are appropriate when streets are narrow and enclosed.

Communities can develop a set of criteria (high levels of pedestrian activity or transit service, redevelopment that will bring buildings closer to the street, etc.) that can make higher speed streets candidates for redesign. This redesign might involve infrastructure changes involving curbs, trees and utilities – or may simply involve restriping and reallocating space on the street (see Arterial Speed Management below). Once identified and when well implemented, these changes should reduce operating speeds and a speed study conducted afterward should result in a lower, compliant speed limit for the street.





## NEIGHBORHOOD STREET SPEED MANAGEMENT

The management of traffic speeds on neighborhood streets is governed by the Carlsbad Residential Traffic Management Program (CRTMP). This program was approved in 2001 and revised in 2011 to help address concerns from residents about speeding and cut-through traffic on residential streets. The CRTMP utilizes a phased approach with increasing levels of complexity and cost and offers a number of

### MORE INFORMATION

- AASHTO: Guide for the Planning, Design, and Operation of Pedestrian Facilities, 2004: Section 2.6.2: Traffic-Calming Methods; Section 3.3.1: Curb Radii; Section 3.3.2: Crossing Distance Considerations
- Ewing, R. and J. Brown: U.S. Traffic Calming Manual. 2009
- NACTO: Urban Street Design Guide, 2013

### DESIGN POLICIES

- The number of chicanes required depends on the length of the street, but generally a series of at least three bulb-outs are needed to create the S-shaped curves needed to slow vehicle speeds.
- The shifts in alignment should be at least one lane width, with deflection angles of at least 45 degrees, and center islands to prevent drivers from following a straight “racing line” path through the feature.
- Chicanes should be placed midblock and may be used in conjunction with other traffic calming measures.
- Chicanes may not be practical in residential areas due to driveways or streets where on-street parking is in high demand.

tools that can be considered for traffic calming.

## CHICANE

Chicanes are curb extensions that alternate from one side of the street to the other, forming S-shaped curves. Vehicles slow their speeds to pass through the series of curves. A chicane-like effect can be achieved sometimes at less cost, by alternating on-street parking from one side of the street to the other. Chicanes can be landscaped to provide visual amenity and neighborhood identity, as well as to provide mid-point refuge for pedestrian crossings at crosswalks.

### MINIMUM PREFERRED DIMENSIONS

Widths should not narrow any bike or general traffic lanes to an unsafe width. Where application of chicanes impact drainage a one to two foot gap may be placed between the treatment and the curb.

## CHICANE

### MODAL PRIORITY



NEW INSTALLATIONS

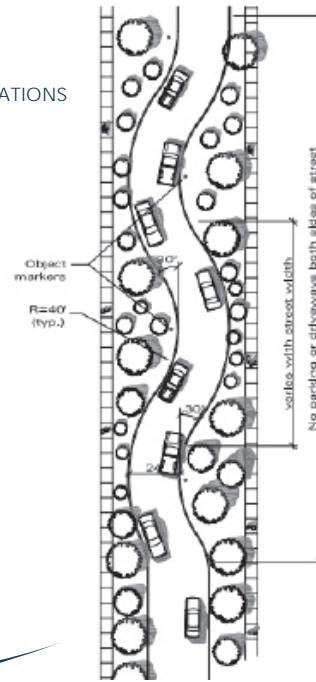



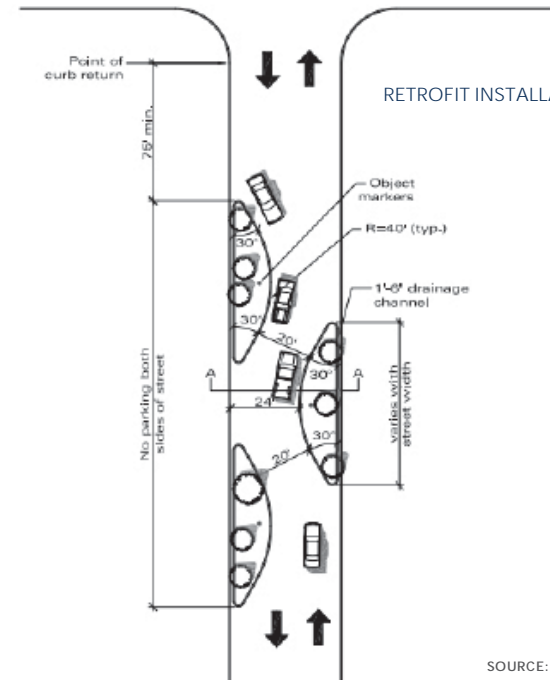



RETROFIT INSTALLATIONS



SOURCE: MASSDOT

Chicane – Design Concepts

 <p><b>LOCATION</b></p> <ul style="list-style-type: none"> <li>• SIDEWALK</li> <li>• CURB</li> <li>• MIDBLOCK</li> <li>• CARTWAY</li> <li>• INTERSECTION</li> </ul>	 <p><b>STREET TYPE</b></p> <ul style="list-style-type: none"> <li>• NEIGHBORHOOD</li> <li>• COLLECTORS</li> <li>• ARTERIALS</li> </ul>	 <p><b>CONTEXT</b></p> <ul style="list-style-type: none"> <li>• URBAN VILLAGE</li> <li>• SUBURBAN</li> </ul>	 <p><b>SPEED LIMIT 25</b></p> <p><b>DRIVING SPEED</b></p> <ul style="list-style-type: none"> <li>• LOW (20MPH OR LOWER)</li> <li>• MEDIUM (25-35MPH)</li> <li>• HIGH (30-45MPH)</li> </ul>	 <p><b>TRAFFIC VOLUME</b></p> <ul style="list-style-type: none"> <li>• LOW (LESS THAN 2K)</li> <li>• MEDIUM (2K-20K)</li> <li>• HIGH (20K-60K)</li> <li>• VERY HIGH (MORE THAN 60K)</li> </ul>	 <p><b>INTERSECTION CONTROL</b></p> <ul style="list-style-type: none"> <li>• YIELD</li> <li>• STOP</li> <li>• SIGNAL</li> </ul>
---	--	--	--	--	---



## CHOKER OR NECK-DOWN

Chokers are midblock curb extensions that narrow the street by expanding the sidewalk or adding a planting strip and often are installed at midblock pedestrian crossings. Neck-downs are curb extensions at intersections that tighten the curb radii at the corner, reducing the pedestrian crossing distance and the speeds of turning vehicles. Both treatments are particularly useful on streets with longer block lengths where motorists tend to pick up speed.

### MORE INFORMATION

- AASHTO: Guide for the Planning, Design, and Operation of Pedestrian Facilities, 2004: Section 2.6.2: Traffic-Calming Methods; Section 3.3.1: Curb Radii; Section 3.3.2: Crossing Distance Considerations
- Ewing, R. and J. Brown: U.S. Traffic Calming Manual. 2009
- NACTO: Urban Street Design Guide, 2013

### DESIGN POLICIES

- Neck-downs and chokers may be coupled with on-street parking bays and crosswalks.
- Neck-downs should not be used on streets with separated bike lanes or other separated facilities where they would result in moving bicyclists into the traffic flow.

### MINIMUM PREFERRED DIMENSIONS

Widths should not narrow any bike or general traffic lanes to an unsafe width.

## CHOKER OR NECK-DOWN

### MODAL PRIORITY



SOURCE: EASTERN SHORE LAND CONSERVANCY

Neighborhood Street Neck-Down – Edmonston, Maryland



#### LOCATION

- SIDEWALK
- CURB
- MIDBLOCK
- CARTWAY
- INTERSECTION



#### STREET TYPE

- NEIGHBORHOOD
- COLLECTORS
- ARTERIALS



#### CONTEXT

- URBAN VILLAGE
- SUBURBAN



#### DRIVING SPEED

- LOW (20MPH OR LOWER)
- MEDIUM (25-35MPH)
- HIGH (30-45MPH)



#### TRAFFIC VOLUME

- LOW (LESS THAN 2K)
- MEDIUM (2K-20K)
- HIGH (20K-60K)
- VERY HIGH (MORE THAN 60K)



#### INTERSECTION CONTROL

- YIELD
- STOP
- SIGNAL





## SPEED HUMPS

Speed humps are parabolic vertical traffic calming devices intended to slow traffic speeds on low volume, low speed roads. Speed humps reduce speeds to 15–20 mph and are often referred to as “bumps” on signage and by the general public. They are most common on lower order neighborhood streets. They may also be used on streets where traffic volumes are higher than desired or those that are used by cut-through traffic on a regular basis.

### MORE INFORMATION

- AASHTO: Guide for the Planning, Design, and Operation of Pedestrian Facilities, 2004
- AASHTO: Guide for the Development of Bicycle Facilities, 2012
- NACTO: Urban Street Design Guide, 2013

### DESIGN POLICIES

- Speed humps should be applied on streets with speeds limits less than 30 mph, and where there is higher than desired operating speeds.
- Speed humps should be accompanied by a sign warning drivers of the upcoming device. They should be located where there is sufficient visibility and available lighting
- Speed humps should not be placed in front of driveways or other significant access areas.
- Spacing should be determined based on the target speed of the roadway. Speed humps should be spaced no more than a maximum of 500 feet apart to achieve an 85th percentile speed of 25–35 mph. To achieve greater speed reductions, space speed humps close together.
- Speed humps may be applied on one-way or two-way roads.
- Carlsbad utilizes a speed cushion design for use in the CRTMP. The speed cushion was designed in cooperation with the Police and Fire Departments and feature wheel tracks that minimize vertical deflection for wide-tracked emergency response vehicles.

### MINIMUM PREFERRED DIMENSIONS

Speed humps should be three to four inches high and 12–14 feet wide, with a ramp length of three to six feet, depending on target speed.

## SPEED HUMPS

### MODAL PRIORITY



Speed Hump – Corvallis, Oregon

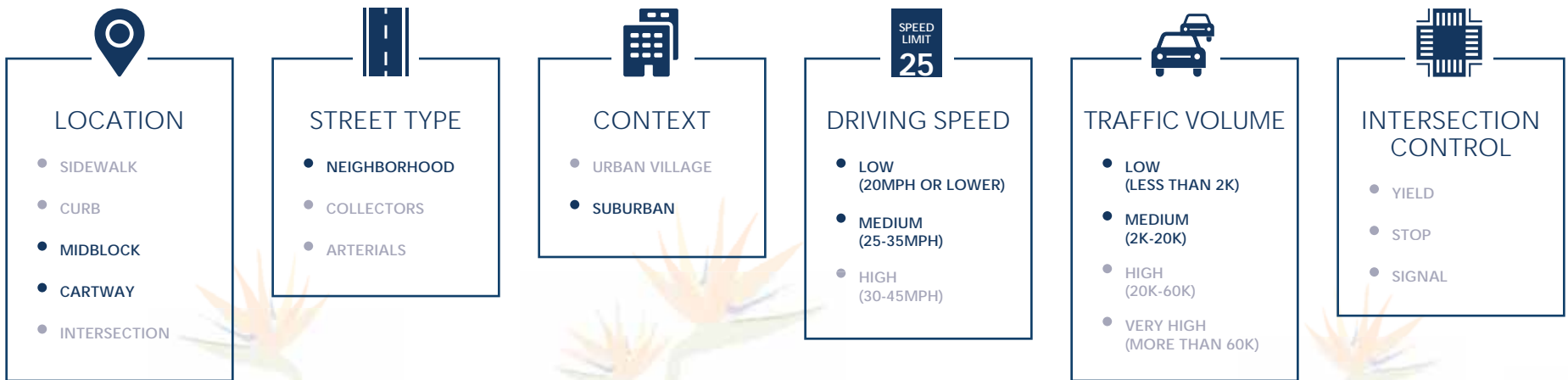



## TRAFFIC CIRCLES

Mini traffic circles are small traffic circles used at the intersection of local streets to slow the speed of traffic. They may or may not be used in conjunction with stop signs. Traffic circles provide advantages for all road users as they reduce the need for a full stop and enable continuous progression when conflicting traffic is not present. An ideal treatment for uncontrolled intersections, traffic circles can reduce vehicle speeds and crashes in low volume areas. They can be installed using simple markings or raised islands, but they also provide great opportunities to include stormwater management facilities or pieces of art.

### MORE INFORMATION

- ITE: Designing Walkable Urban Thoroughfares: A Context Sensitive Approach, 2010
- AASHTO: Guide for the Development of Bicycle Facilities, 2012
- NACTO: Urban Street Design Guide, 2013

### DESIGN POLICIES

- Regulatory and/or warning signage should be provided to remind traffic to proceed counterclockwise around the circle.
- Landscaping medians reduce the impervious surface area in the roadway, allowing stormwater infiltration or retention in the exposed soil.
- Street trees located in traffic circles should avoid blocking sight lines to ensure safety. A neighborhood partner should be identified for maintenance of any plantings.
- If plantings are incorporated, they should require minimal maintenance; access paths for maintenance crews should be incorporated into the overall design.

### MINIMUM PREFERRED DIMENSIONS

Provide approximately 15 feet of clearance from the corner to the widest point on the circle.

## TRAFFIC CIRCLES

### MODAL PRIORITY



Traffic Circle – Santa Monica, California

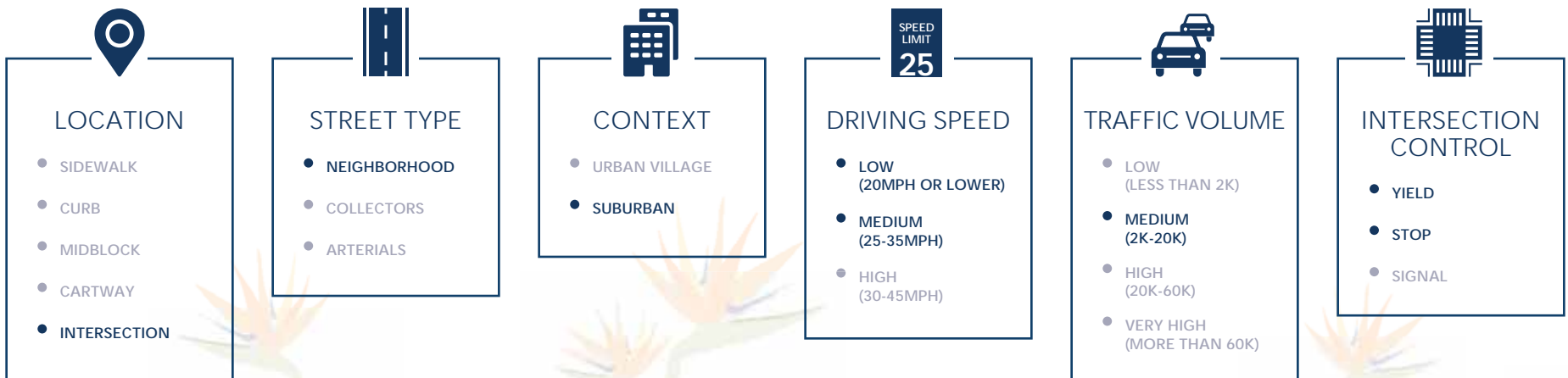



## DIVERTERS

Diverters are physical or regulatory barriers that restrict access and movement. They may prevent particular turning or through movements or restrict access to local traffic only, while allowing passage of bicycle and pedestrian traffic. Diverters can create opportunities for landscaping and street trees. Depending on the situation, diverters can be appropriate for use on all street types. Sometimes called a “half street closure,” semi-diverters prevent vehicles from crossing an intersection in one direction of a street while permitting traffic in the opposite direction to pass through. It is an alternative to one-way street operation for a block and it allows residents on the block limited two-way travel opportunity.

### MORE INFORMATION

- AASHTO: Guide for the Planning, Design, and Operation of Pedestrian Facilities, 2004
- AASHTO: Guide for the Development of Bicycle Facilities, 2012
- FHWA: Small Town and Rural Multimodal Networks, Chapter 2: Mixed Traffic Facilities

### DESIGN POLICIES

- A semi-diverter should be located at the end of a block to prevent vehicles from entering, but allowing exits.
- Diagonal diverters can be installed across an intersection blocking through movement, and are usually staggered to create circuitous routes through neighborhoods.
- Diverters should be designed to allow for the passage of pedestrians and bicycles.

### MINIMUM PREFERRED DIMENSIONS

The length of a diverter should be long enough to prevent bypass attempts by vehicles. Gaps should be provided at a minimum of four feet for passage of bicycles and where pedestrian crosswalks occur.

## DIVERTERS

### MODAL PRIORITY



Diverter – Albuquerque, New Mexico



#### LOCATION

- SIDEWALK
- CURB
- MIDBLOCK
- CARTWAY
- INTERSECTION



#### STREET TYPE

- NEIGHBORHOOD
- COLLECTORS
- ARTERIALS



#### CONTEXT

- URBAN VILLAGE
- SUBURBAN



#### DRIVING SPEED

- LOW (20MPH OR LOWER)
- MEDIUM (25-35MPH)
- HIGH (30-45MPH)



#### TRAFFIC VOLUME

- LOW (LESS THAN 2K)
- MEDIUM (2K-20K)
- HIGH (20K-60K)
- VERY HIGH (MORE THAN 60K)



#### INTERSECTION CONTROL

- YIELD
- STOP
- SIGNAL

## ARTERIAL STREET SPEED MANAGEMENT

### ROAD DIETS

A road diet is the reallocation of roadway space by converting one or more vehicle travel lane(s) to active transportation use while retaining the existing curb line. The most common road diet converts a four lane road with two lanes in each direction to a three lane section with one lane in each direction, one bike lane in each direction, and a center turn lane. This strategy can be applied broadly to a wide variety of cross sections where one or more travel lanes are repurposed to provide more space for people walking and bicycling. Road diets are most typically done on roadways with excess capacity where anticipated traffic volumes have not materialized to support the need for additional travel lanes.

Road diets provide potential for crash reduction. Converting a four lane street to a three lane street removes left turns from the main flow of traffic and has been shown to reduce the number of rear-end collisions, for example, since left turning motorists can wait to turn in the center lane. Four to three lane conversions typically have minimal effects on the vehicular capacity of the roadway because left-turning vehicles are moved into a common two-way left turn lane. Roadway configurations with two travel lanes and a center turn lane can discourage speeding and weaving; reduce the potential for rear end and side swipe collisions; improve sight distances for left-turning vehicles; reduce pedestrian crossing distances and exposure to motor vehicle traffic; and reallocate space for sidewalks, bicycle facilities, and bus bulbs.

#### MORE INFORMATION

- AASHTO: Guide for the Development of Bicycle Facilities, 2012: Section 4.9.2: Retrofitting Bicycle Facilities Without Roadway Widening
- Federal Highway Administration: Road Diet Informational Guide, 2014
- Federal Highway Administration: Traffic Calming ePrimer, 2017



#### DESIGN POLICIES

- If considered during reconstruction, raised center islands may be constructed in between intersections to provide improved pedestrian crossings, incorporate landscape elements, and reduce travel speeds.
- Policy 3-P.15 of the Mobility Element states, "the City Council shall have the sole discretion to approve any such road diet or vehicle traffic calming improvements that would reduce vehicle capacity to or below a LOS D; this also applies to streets where the vehicle is not subject to the MMLOS standard as specified in Table 3-1."

## ROAD DIETS

### MODAL PRIORITY



Road Diet Implementation – San Mateo, California

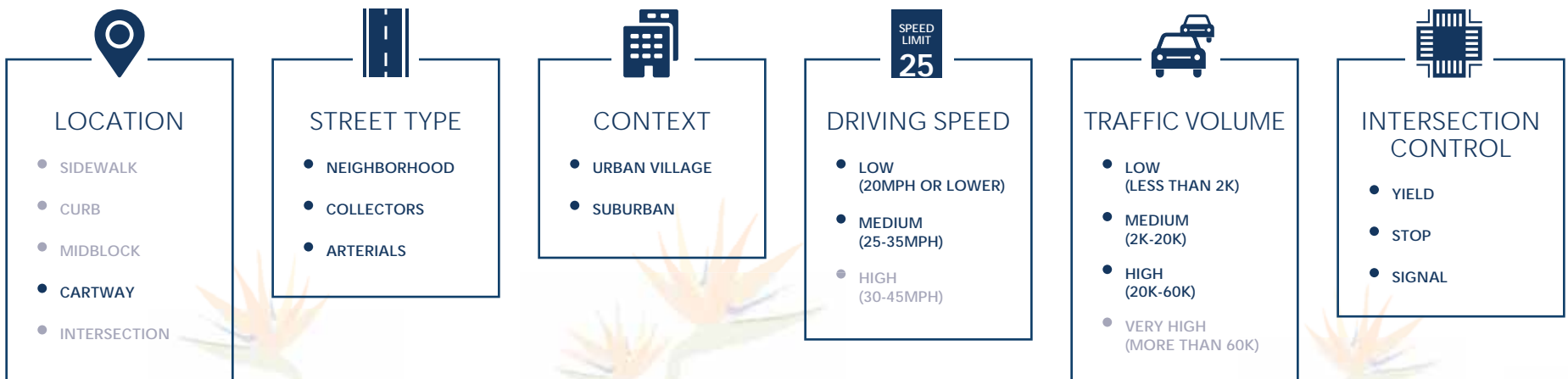





## SIGNAL MODIFICATIONS

Modifications to traffic control devices can improve driver compliance by increasing the visibility of a signal and making phasing easier to understand. These modifications can include altering timing and phasing in order to separate movements and optimize flow, such as by adding a separated left turn phase, which restricts pedestrian movement during left turning movements. Phasing modifications benefit people using active transportation by increasing their visibility to drivers, reducing the risk of crashes and injuries. Physical modifications include such enhancements as retroreflective backplates/borders on signs and traffic signal heads, and LEDs or flashing beacons used in conjunction with warning or regulatory signs. Traffic signal displays can also be outfitted with signal visors, limited visibility lenses, or signal louvers to prevent preemptive movements and minimize confusion about the right of way among adjacent movements.

### DESIGN POLICIES

- Stop signs and warning signs may be accompanied by LED units along the border of the sign for illumination (not including changeable message signs).
- Signal backplates can be vented to account for higher wind loads.
- Louvers, the inside surfaces of visors, and the front surface of backplates must retain a matte black finish.
- Retroreflective borders on signal backplates offer enhanced visibility at night and during power outages.

### MORE INFORMATION

- Federal Highway Administration. Signalized Intersections: Informational Guide. Second Edition. 2013.
- California Manual on Uniform Traffic Control Devices (2014, Chapter 4A-4K)

## SIGNAL MODIFICATIONS

### MODAL PRIORITY

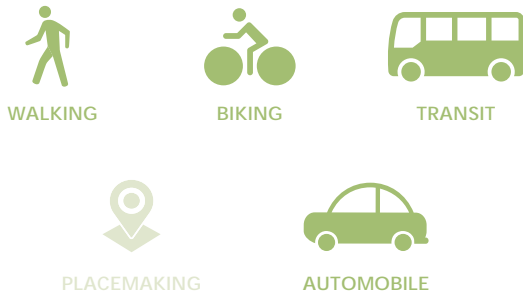

Signal – Long Beach, California

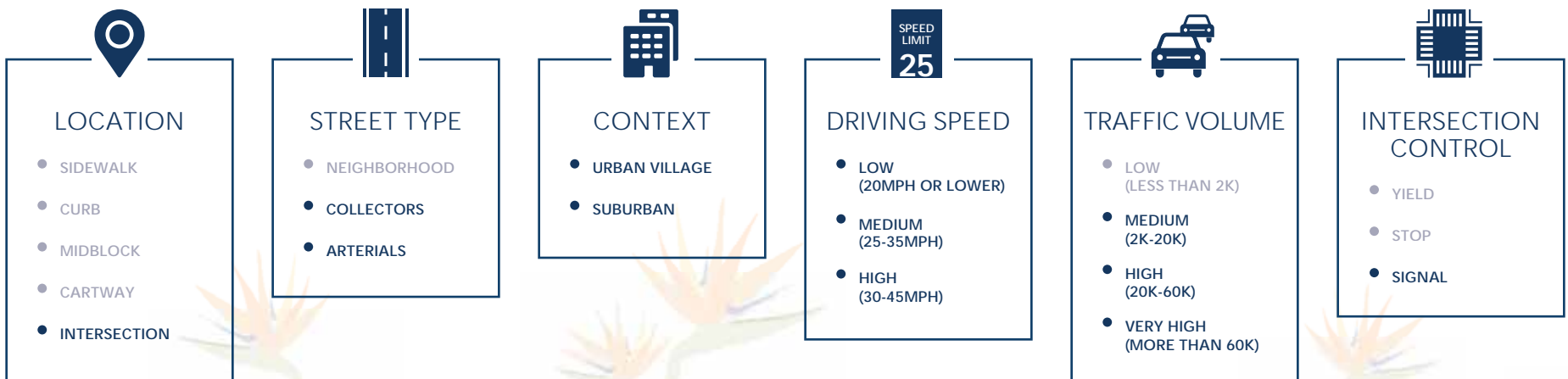



## MEDIANS

A median divides lanes of traffic and is generally located in the center of the right-of-way to separate opposing directions of traffic. They may also be used off-center to separate local access or special purpose lanes, including bicycle facilities and bus-only lanes. Medians increase safety and enhance roadway operations by reducing vehicular movement conflicts, limiting turning movements, and providing a refuge for pedestrians crossing the street.

### MORE INFORMATION

- AASHTO: Guide for the Planning, Design, and Operation of Pedestrian Facilities, 2004
- Federal Highway Administration: Small Town and Rural Multimodal Networks, Chapter 2: Mixed Traffic Facilities
- NACTO: Urban Street Design Guide, 2013

### DESIGN POLICIES

- Medians take many forms and can be used as both a traffic calming and beautification device.
- Medians may be flush with the pavement and consist of painted markings, or a space separated with a raised curb.
- Striped or painted medians may precede more permanent improvements, providing an opportunity to test travel behaviors before making a significant capital investment.
- Medians that intersect a pedestrian crossing should have a clear walk zone that is at least as wide as the crosswalk that intersects it to avoid a bottleneck mid-crossing.

### MINIMUM PREFERRED DIMENSIONS

Medians must be at least 10 feet wide (curb to curb) if they are to provide turn pockets at intersections. Medians intended for use as pedestrian refuge islands should be a minimum of six feet wide (curb to curb) to provide adequate width for pedestrians crossing with strollers, bicycles or wheelchair devices.

## MEDIANS

### MODAL PRIORITY



Landscaped Median – Carlsbad



#### LOCATION

- SIDEWALK
- CURB
- MIDBLOCK
- CARTWAY
- INTERSECTION



#### STREET TYPE

- NEIGHBORHOOD
- COLLECTORS
- ARTERIALS



#### CONTEXT

- URBAN VILLAGE
- SUBURBAN



#### DRIVING SPEED

- LOW (20MPH OR LOWER)
- MEDIUM (25-35MPH)
- HIGH (30-45MPH)



#### TRAFFIC VOLUME

- LOW (LESS THAN 2K)
- MEDIUM (2K-20K)
- HIGH (20K-60K)
- VERY HIGH (MORE THAN 60K)



#### INTERSECTION CONTROL

- YIELD
- STOP
- SIGNAL

## SPEED MANAGEMENT TOOLS

### ADDITIONAL SIGNALS

Signals are the tools that help move traffic through intersections. Typical arterial signal spacing is a half-mile or more, which does not correlate well to a pedestrian-scaled network. On a low-speed street, signals are not as necessary to manage speeds, but on arterials and collectors signals can allow for cross-flow, keep vehicle traffic moving at safe speeds, and allow for access to destinations. MUTCD provides recommendations on signal spacing, but also states that locations that do not meet warrants could still include signals with application of engineering judgment.

#### MORE INFORMATION

- AASHTO: Guide for the Development of Bicycle Facilities, 2012: Section 4.9.2: Retrofitting Bicycle Facilities Without Roadway Widening
- NACTO: Urban Street Design Guide, 2013

### REDUCED LANE WIDTH

Analysis of a street's layout may reveal space that could be allocated from vehicular uses to other elements. Where a road diet or cycle track might be infeasible, narrowing vehicle lanes may allow for the inclusion of on-street parking, wider sidewalks, landscaping treatments, or bicycle lanes without causing any safety effects to vehicular traffic.

### TRANSITIONS

As context and mobility functions change, street type designations may change accordingly. The transitions between street types can include design cues reinforcing the street's desired character relative to its changing context. For example, state highways that function as main streets on entering a commercial district might introduce more urban elements (narrower lanes, curb and gutter edges, pedestrian lighting, gateway treatments, etc.) to cue motorists to the transition from a higher-speed mobility corridor to a lower-speed, walkable commercial district.

<sup>5</sup> Federal Highway Administration. "4C: Traffic Control Signal Needs Studies," in Manual of Uniform Traffic Control Devices, 2009 Edition with Revisions No. 1 and 2 Incorporated. 2012.

## TRANSIT OPERATIONS

### BUS PRIORITY TREATMENTS

While currently there are no on-street bus facilities in Carlsbad, peak only bus lanes, fully dedicated bus lanes, and queue jumps should be considered as a strategy to improve mobility when warranted.

Warrants should be developed based on the net gains that can be achieved in person travel time for all users of the roadway, as well as improvements in schedule adherence. The following types of metrics should be included in the development of warrants for bus only lanes and queue jumps.<sup>6</sup>

- Transit frequency in the corridor
- Percent of passengers carried by buses versus the adjacent traffic lane
- Increase in bus travel times during congested conditions
- Schedule adherence

### DEDICATED TRANSIT LANES

Transit vehicles may operate in lanes shared by general traffic or in their own dedicated lanes. Dedicated transit lanes can be used to improve frequent transit service on busy streets by reducing traffic delays and increasing the reliability of high-quality transit service. They can be dedicated at all times, or only for peak transit periods, which can provide space for other uses during non-peak periods of the day such as parking or shared bike facilities. Transit lanes are recommended for use on priority transit corridors, where transit service is frequent (headways of ten minutes or less), ridership is high, and traffic congestion interferes with transit operations. These dedicated lanes are generally discouraged on streets where transit service is not frequent, and on non-mobility corridors.

NACTO recommends 10-12 feet of width for dedicated transit lanes. If the target width of 11 feet cannot be met within a constrained cross-section, the transit lane may be reduced to 10 feet wide. However, 10-foot lanes are only recommended in constrained conditions where speeds are 25 mph or below. A transit lane should not exceed 12 feet in width, unless that width includes some form of physical separation from the adjacent lane. Appropriate markings and signage should be used to identify restricted hours and permitted users. High visibility "BUS ONLY" pavement markings (MUTCD 3D-01) can be used to discourage encroachment by other users. Intersections with high volumes of turning movements may require special merge zone markings to mitigate conflict between motorists and transit vehicles.

<sup>6</sup> Litman, Todd, When are Bus Lanes Warranted?, Victoria Transport Policy Institute, (2016), 10. (<http://www.vtpi.org/blw.pdf>)

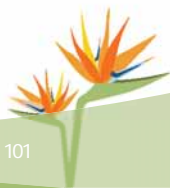

## TRANSIT SIGNAL PRIORITY

Transit signal priority (TSP) can be both active and passive, and each has its own advantages. The passive form of TSP is similar to that of the Green Wave for bicyclists, but with the signal progression set for the speed of on-street transit (12 - 20 mph). This tool is most ideal for use in combination with short cycle lengths. Active TSP comes in the form of an on-board device that communicates with the traffic signals to modify the signal timing or phasing. This tool is most ideal on corridors with longer cycle lengths, longer distances between signals, and longer service headways. It is also recommended that this tool be used in combination with queue jump lanes, or full transit-only lanes.

## QUEUE JUMPS

A queue jump provides buses with an exclusive lane and advanced signal priority to bypass vehicle queues at an intersection. It is viable at all stop configurations and with or without a bus station or stop. Positive results of this transit priority method include improved on-time performance and decreased route travel times, both of which improve overall service reliability. The technology and infrastructure necessary for this system includes a separate signal head to alert bus operators when to safely advance through the intersection and vehicle detector to sense when a transit vehicle is present.

## MORE INFORMATION

- MTS: Designing for Transit, 2018
- NACTO: Transit Street Design Guide



## BUS PRIORITY TREATMENTS

### MODAL PRIORITY



SOURCE: NCTD

NCTD Breeze Bus

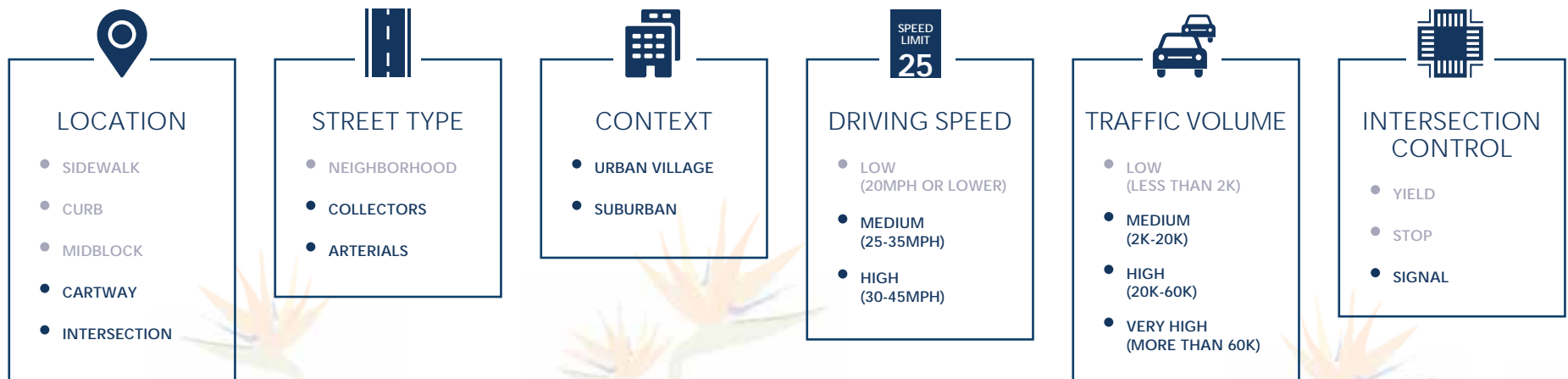



## TEMPORARY TRAFFIC CONTROL

When normal function of a roadway is suspended due to maintenance, utility work, or adjacent construction, temporary traffic controls (TTC) should be implemented to ensure the continuity of accessible passage for bicycle and pedestrian traffic, including users with disabilities. TTC zones should be monitored under varying conditions of user volumes, light, and weather to ensure control devices are effective and visible during all conditions. Implementation of TTC zones can be coupled with media outreach and press releases in order to better inform of the public of temporary travel conditions. The City of Carlsbad Traffic Division is responsible for review of traffic control plans for construction projects (see figure to right).

### MORE INFORMATION

- CA MUTCD: California Manual on Uniform Traffic Control Devices, 2014: Chapter 6 Temporary Traffic Control
- American Road & Transportation Builders Association: Temporary Traffic Control Zone Pedestrian Access Considerations, 2019

General makeup of a TTC zone is as follows:

1. Advance Warning Area: Segment where users are informed of upcoming work zone through signage.
2. Transition Area: Segment where users are redirected out of their normal path to a new path with use of tapers.
3. Activity Area: Segment where work activity takes place buffered from traffic.
4. Termination Area: Segment where users are returned to their normal path of travel from the downstream end of the work area to a final TTC device such as an END ROAD WORK sign.



### DESIGN POLICIES

- TTC zones should be designed on the assumption that drivers will only reduce their speeds if they clearly perceive a need to do so.
- All modes should be guided in a clear manner while approaching and traversing TTC zones.
- If a TTC zone affects movement of pedestrians an adequate alternative pedestrian walkway should be provided. If the TTC zone affects an accessible and detectable pedestrian facility, this features should be maintained along the alternative route.
- Pedestrians should never be led into direct conflicts with work site vehicles, equipment, or traffic maneuvering through the TTC zone.
- If the TTC zone interrupts an existing bikeway, signs directing bicyclists through or around the zone and back to the bikeway should be provided. Unless a separate bike path through or around the zone is provided, adequate roadway lane width should be provided to allow the passage of bicycles and motor vehicles side by side. If roadway width is inadequate, warning signs should be used to advise motorists on the presences of bicyclists in travel lanes.

City Approved Temporary Traffic Control Measures

## TRAFFIC CONTROL NOTES

1. WORK HOURS TO BE RESTRICTED TO \_\_\_\_\_ TO \_\_\_\_\_ UNLESS APPROVED OTHERWISE.
2. PEDESTRIAN CONTROLS WILL BE PROVIDED AS SHOWN.
3. PEDESTRIANS SHALL BE PROTECTED FROM ENTERING THE EXCAVATION BY PHYSICAL BARRIERS DESIGNED, INSTALLED, AND MAINTAINED TO THE SATISFACTION OF THE CITY ENGINEER.
4. TEMPORARY "NO PARKING/TOW AWAY" SIGNS STATING THE DATE AND TIME OF PROHIBITION WILL BE POSTED 72 HOURS PRIOR TO COMMENCING WORK. CALL CARLSBAD POLICE DISPATCH AT (760)931-2907 TO VALIDATE POSTING.
5. ACCESS WILL BE MAINTAINED TO ALL DRIVEWAYS UNLESS OTHER ARRANGEMENTS ARE MADE.
6. TRENCHES MUST BE BACKFILLED OR PLATED DURING NON-WORKING HOURS UNLESS K-RAIL BARRIERS ARE PROVIDED. K-RAIL IS APPROVED ONLY WHEN SPECIFICALLY SHOWN ON THE APPROVED TRAFFIC CONTROL PLAN. PLATES SHALL HAVE CLEATS AND COLD MIX AT THE EDGES AS APPROVED BY THE CITY INSPECTOR.
7. STOPPING WILL BE REPLACED BY THE CONTRACTOR WITHIN 24 HOURS, IF REMOVED OR DAMAGED.
8. WORK THAT DISTURBS NORMAL TRAFFIC SIGNAL TIMING OPERATIONS SHALL BE COORDINATED WITH THE CITY OF CARLSBAD, CONTACT STREETS DIVISION AT (760) 434-2977 72 HOURS PRIOR TO COMMENCING WORK.
9. TRAFFIC SIGNALS SHALL REMAIN FULLY ACTUATED AT ALL TIMES, UNLESS OTHERWISE APPROVED BY THE CITY ENGINEER OR HIS REPRESENTATIVE. IF TRAFFIC SIGNAL LOOP DETECTORS ARE RENDERED INOPERATIVE BY THE PROPOSED WORK, LOOP DETECTION SHALL BE USED TO PROVIDE ACTUATION.
10. FLAGGERS SHALL BE EQUIPPED WITH A WHITE HARD HAT, AN ORANGE VEST, AND A "STOP/SLOW" PADDLE ON A 5 FOOT STAFF.
11. ALL TRAFFIC CONTROL DEVICES MUST BE MAINTAINED 24 HOURS A DAY, 7 DAYS PER WEEK, BY THE CONTRACTOR.
12. ALL TRAFFIC CONTROL SHALL BE IN ACCORDANCE WITH THE CALIFORNIA MANUAL ON UNIFORM TRAFFIC CONTROL DEVICES (LATEST VERSION).
13. TRAFFIC CONTROL PLAN SUBMITTALS ARE REQUIRED FOR EACH PHASE OF THE WORK IN THE DETAIL, FORMAT, AND QUALITY ILLUSTRATED ON THIS SHEET.
14. ALL TRAFFIC CONTROL DEVICES SHALL BE REMOVED FROM VIEW OR COVERED WHEN NOT IN USE.
15. THE CITY ENGINEER OR HIS REPRESENTATIVE HAS THE AUTHORITY TO INVOKE FIELD CHANGES TO INSURE PUBLIC SAFETY.
16. ALL WORK AFFECTING BUS STOPS SHALL BE COORDINATED WITH NORTH COUNTY TRANSIT DISTRICT. CONTRACTOR SHALL CALL NCTD AT (760) 867-2028 AT LEAST 72 HOURS IN ADVANCE OF STARTING WORK.
17. CHANGEABLE MESSAGE SIGNS SHALL BE USED IN ADVANCE OF TRAFFIC CONTROL ON MAJOR AND PRIME ARTERIALS, UNLESS OTHERWISE APPROVED. THESE SIGNS SHALL BE SHOWN ON THE TRAFFIC CONTROL PLAN.

## SIGNAGE NOTES

1. AT LEAST ONE PERSON SHALL BE ASSIGNED TO FULL TIME MAINTENANCE OF TRAFFIC CONTROL DEVICES ON ALL NIGHT LANE CLOSURES.
2. ALL WARNING SIGNS FOR NIGHT LANE CLOSURES SHALL BE ILLUMINATED OR REFLECTORIZED AS SPECIFIED IN THE SPECIFICATIONS.
3. ALL ADVANCE WARNING SIGN INSTALLATIONS SHALL BE EQUIPPED WITH FLAGS FOR DAYTIME CLOSURES OF ALL MAJOR AND PRIME ARTERIALS. FLASHING BEACONS SHALL BE USED DURING NIGHT LANE CLOSURES.
4. A G20-2 "END ROAD WORK" SIGN SHALL BE PLACED AT THE END OF THE LANE CLOSURE UNLESS THE END OF THE WORK AREA IS OBVIOUS, OR ENDS WITHIN A LARGER PROJECT LIMITS.
5. ALL CONES USED FOR NIGHT LANE CLOSURES SHALL BE ILLUMINATED TRAFFIC CONES OR FITTED WITH 12" REFLECTIVE SLEEVES.
6. FLASHING ARROW SIGNS SHALL BE USED FOR THE CALIFORNIA MUTCD. SILENT TYPE SHALL BE USED IN RESIDENTIAL AREAS.
7. THE MAXIMUM SPACING BETWEEN CONES IN A TAPER OR A TANGENT SHALL BE APPROXIMATELY AS SHOWN IN TABLE 1.
8. ADDITIONAL ADVANCE FLAGGERS SHALL BE REQUIRED WHEN TRAFFIC QUEUES DEVELOP. FLAGGER STATIONS FOR WORK AT NIGHT SHALL BE ILLUMINATED AS NOTED IN SECTION 6E.20 OF THE MUTCD.
9. PLACE C90 (CA) "LANE CLOSED" SIGN AT 500'-1000' INTERVALS THROUGHOUT EXTENDED WORK AREAS.
10. ALL REQUIRED SIGNS THAT ARE TO BE LEFT IN PLACE OVER A WEEKEND OR HOLIDAY SHALL BE POST MOUNTED.
11. CONSTRUCTION AREA TRAFFIC CONTROL DEVICES SHALL MEET THE PROVISIONS OF SECTION 12 OF THE MOST RECENT EDITION OF THE CALTRANS STANDARD SPECIFICATIONS.

## SIGNS

	W20-2		W1-3(LT)
	W20-5(RT)		W13-1
	W20-5(LT)		G20-2
	W20-5(BIKE)		R9-9
	W20-1		R9-11a
	W20-4		R9-10
	W21-5		R4-7a
	W3-4		C9A(CA)
	W4-2(RT)		C30(CA)
	W1-4(LT)		C30A(CA)
	W1-4(RT)		C30(BIKE)



# 8

# INTERSECTIONS & CROSSINGS



## 8

### INTERSECTIONS & CROSSINGS

As locations where multimodal conflicts are most present, the design of intersections and crossings are vital to implementing complete streets. Design of intersections has a direct impact on vehicular speeds and the exposure to which pedestrians and bicyclists face. Intersections and crossings also have a significant impact on the mobility and comfort of multimodal users. The speed and ease with which pedestrians and bicyclists can pass through an intersection is dependent on signal phasing, crossing distance and the presence of physical treatments such as medians and warning devices.



## DESIGN CONTROLS

### DESIGN VEHICLE

The design vehicle influences several geometric design features including lane width, corner radii, median nose design, and slip lane design. It is critical not to use a larger design vehicle than necessary, due to negative impacts such as turning speed, yielding behavior and crossing distances.

Conventional practice relies on the design vehicle to establish turning radii. The larger the design vehicle, the wider the turning radius. This facilitates truck movements but expands the size of intersections, lengthens pedestrian crossings, and creates a turn that passenger vehicles and smaller freight vehicles can navigate at higher speeds than the design vehicle.<sup>7</sup>

The SU-30 is an infrequent user of most urban residential streets. Incorporating a new design vehicle such as a 23-foot delivery truck (DL-23) allows access for the largest frequent urban street user. With an inside turning radius of 22.5-feet and an outside turning radius of 29-feet, the DL-23 is closer, operationally, to a passenger vehicle.

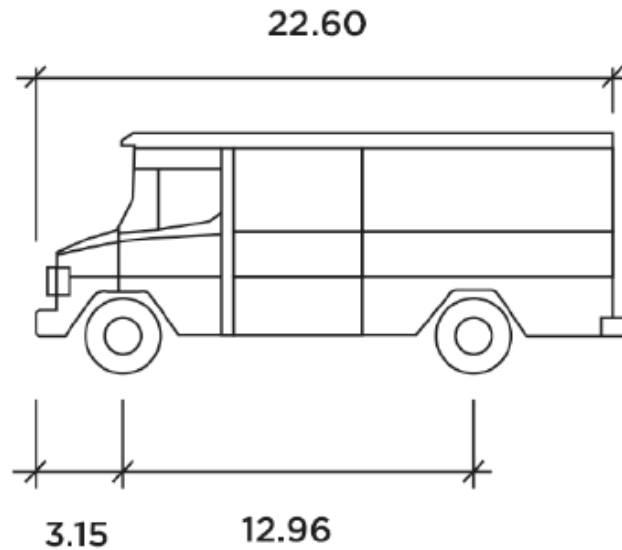

<b>O2</b>	<b>feet</b>
<b>Width</b>	<b>: 7.12</b>
<b>Track</b>	<b>: 7.12</b>
<b>Lock to Lock time</b>	<b>: 6.0</b>
<b>Steering Angle</b>	<b>: 42.0</b>

Design Vehicle – Preferred Dimensions

#### MORE INFORMATION

- Complete Streets Chicago: Design Guidelines
- Federal Highway Administration. Achieving Multimodal Networks: Applying Design Flexibility and Reducing Conflicts, 2016
- NACTO: Urban Street Design Guide, 2013

<sup>7</sup> AASHTO notes that “(an intersection designed to accommodate trucks with no encroachment into adjacent lanes needs large corner radii, wide turning roadways, and greater distances for pedestrians to cross. Motorists can often negotiate these turns at speeds that are too fast to adequately detect and stop for pedestrians crossing the roadway.” Source: American Association of State Highway Transportation Officials, A Policy on Geometric Design of Highways and Streets, 6th ed. 2011: 9-6.

## CORNER DESIGN

Design of intersection corners is critical to implementation of Complete Streets. It directly impacts turning speeds, sight lines, and the placement and length of crosswalks. Corner design includes the radius of the curb, whether or not curb extensions are used, the distance from the corner at which on-street parking may begin, and any other physical element that impacts the operation of the intersection.

It is recommended that the specified corner geometry elements should be based on both the functional emphasis of the intersecting streets and their surrounding context. This will ensure it is built as compact as possible while serving the appropriate use.

## CURB RADIUS

The curb radius refers to the arc of the built curb at the corner of an intersection, which determines the effective turning radius of a vehicle. The turning radius refers to the path of a vehicle's wheels as it turns the corner. Reducing the corner radius effectively reduces a vehicle's turning radius, and restricts turning speeds. A smaller curb radius also reduces the width of the intersection, reducing the length of the pedestrian crossings, and ensuring higher pedestrian visibility by placing pedestrians further into the line of sight for motorists. It is important to note that streets with high volumes of truck, transit, or emergency vehicles may require larger curb radii.

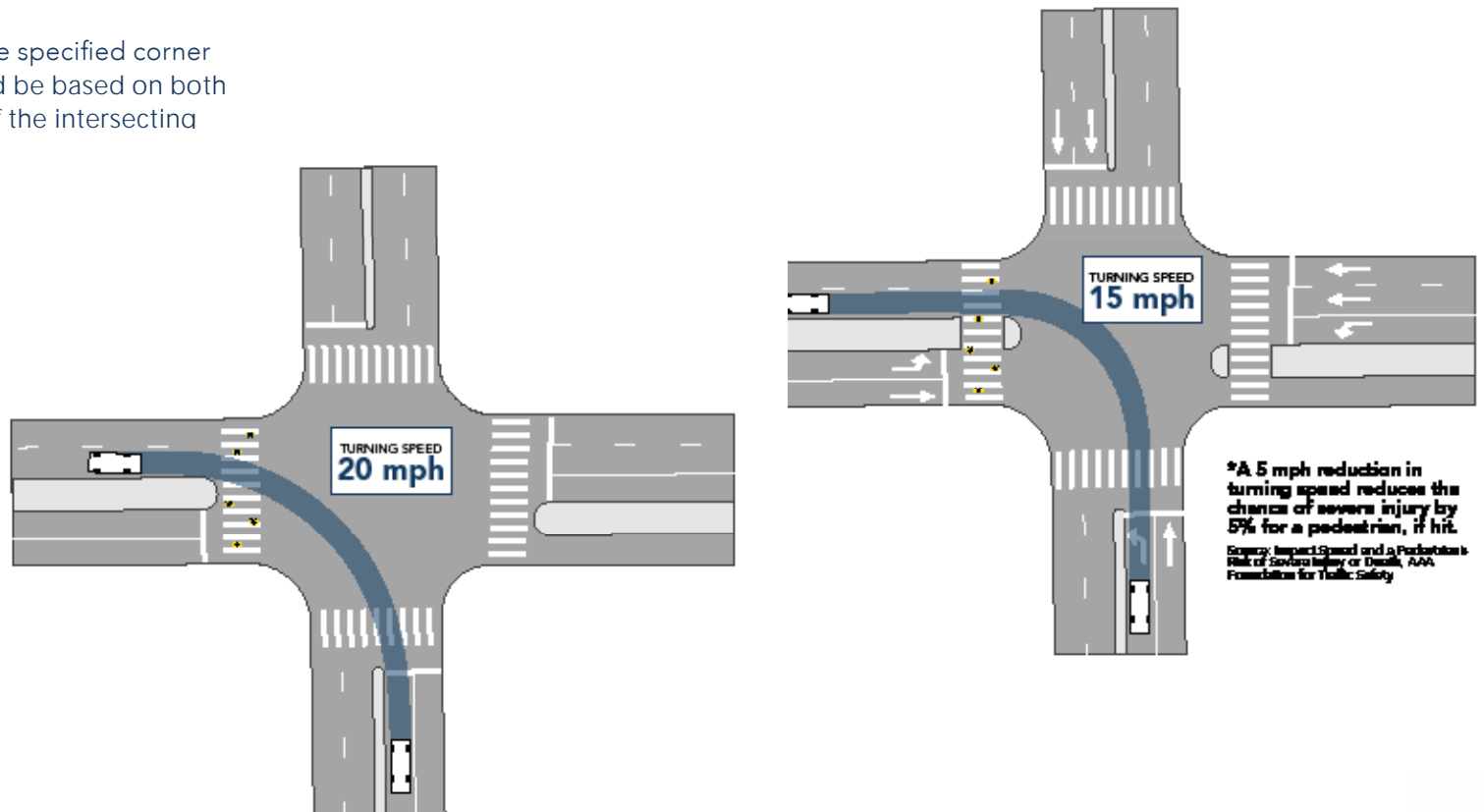

## EFFECTIVE V ACTUAL RADIUS

The corner radius is that of the actual corner. It is also referred to as the corner or curb return radius. The effective turning radius is calculated using the widest turn possible. For example, a truck will turn from the lane closest to the curb (not including the parking or bicycle lane) and into the farthest lane from the curb (up to the center line or median). Whether the actual and effective turning radius is the same depends on the design of the intersection. If the travel lane is not immediately adjacent to the curb due to parking or a bicycle lane, then the two radii are not the same.

While corner radii should be based on the turning radius of the design and control vehicles, corner radii of 15 feet or less and an effective radius of no more than 35 feet are generally desirable, if feasible. Intersections where large vehicles make frequent right turns can have setback stop lines to facilitate right turns but still have relatively short corner curb radius.

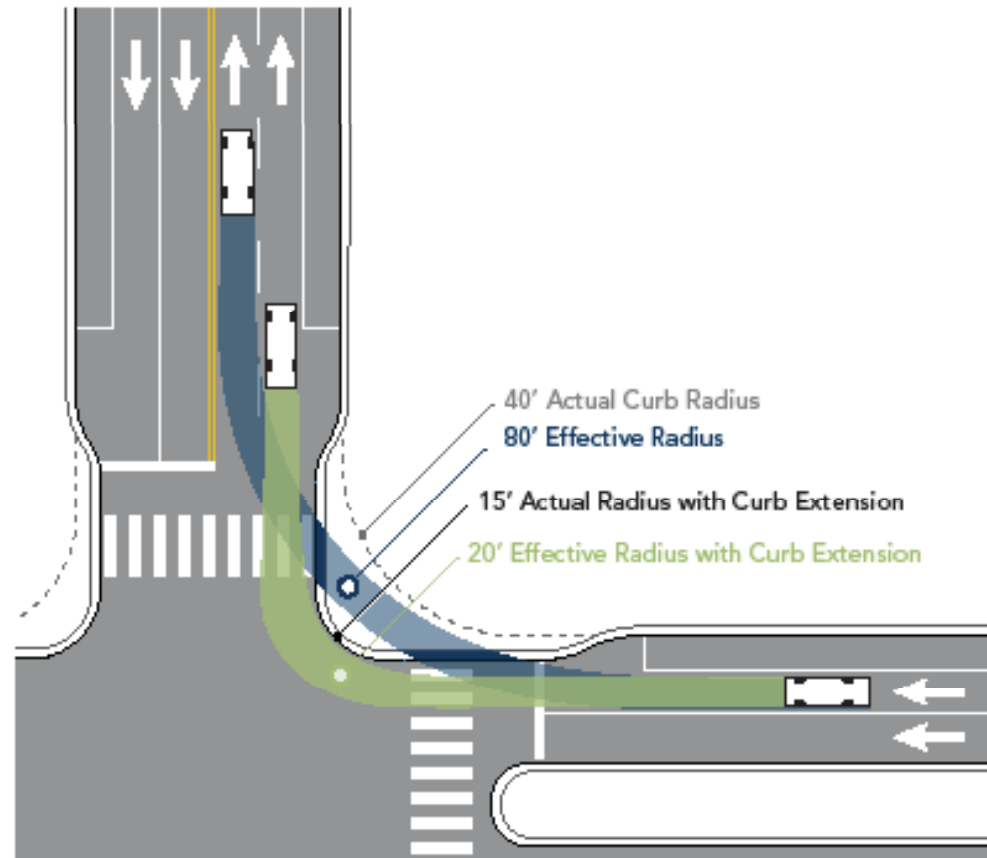

Effective and Actual Turning Radius

### MORE INFORMATION

- AASHTO: Guide for the Planning, Design, and Operation of Pedestrian Facilities, 2004: Section 2.6.2: Traffic-Calming Methods; Section 3.3.1: Curb Radii; Section 3.3.2: Crossing Distance Considerations
- Federal Highway Administration. Achieving Multimodal Networks: Applying Design Flexibility and Reducing Conflicts, 2016
- NACTO: Urban Street Design Guide, 2013

## INTERSECTION DESIGN

### COMPACT INTERSECTIONS

Compact intersections are preferred for establishing a multimodal environment. A compact intersection has a small roadway footprint, fosters eye contact, reduces crossing distances, and reduces speeds. Where compactness is not achievable due to geometry, number of streets, turning requirements, etc., it might be feasible to break up intersections into “mini-intersections” using small roundabouts.

Techniques to create compact intersections include:

- Designing for the largest vehicle that regularly executes the subject movement – FHWA recommends that practitioners use the smallest practical design vehicle<sup>8</sup>
- Calculating turning radius using effective rather than actual radius
- Setting back stop lines to allow wider turns from approaching legs
- Adding pedestrian refuge islands
- Constructing curb extensions where on-street parking is present or in cases where a turn lane is discontinued across an intersection



Compact Intersections – Design Approaches

Approaches to creating compact intersections can be thought of as moving curbs closer together, adding raised areas within the intersection, or a combination

<sup>8</sup> Federal Highway Administration. “Achieving Multimodal Networks: Applying Design Flexibility and Reducing Conflicts.” 2016.





DRAFT

## PEDESTRIAN EXPOSURE

Exposure risk is the amount of time that a person is exposed to potential conflicts. Examples include the amount of time that it takes a person to cross the street, or the amount of time it takes to drive through an intersection. Minimizing exposure risk generally increases safety as it reduces the amount of time users are exposed to a possible crash. Compact intersections, short crossing distances, and intuitive design all reduce exposure. Shorter crossings have the added traffic benefit of less clearance time needed during the flashing don't walk phase.<sup>9</sup>

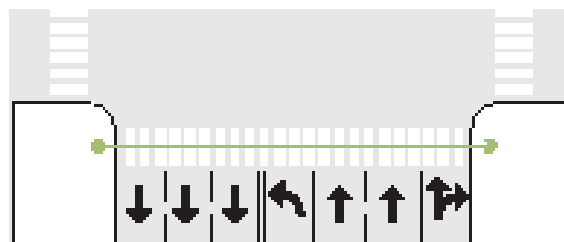

**Crossing distance: 100'**  
**Crossing time: 29-33 sec.**

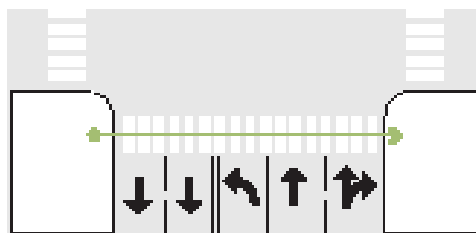

**Crossing distance: 55'**  
**Crossing time: 16-18 sec.**

Impact of Crossing Distance on Pedestrian Exposure

## SIGHT TRIANGLES AND VISIBILITY

Sight triangles are used to determine where vertical elements are prohibited within an intersection in order to maintain adequate sightlines, but they often create wide setbacks and designs that encourage speeding and endanger pedestrians. In multimodal environments, intersection corners tend to become gathering places; pedestrians wait at corners to cross the street, and bus stops are often placed at corners. In these areas it becomes less important to focus on clearing sightlines, but more important to slow traffic speeds and facilitate eye contact between motorists and other street users. At lower speeds a motorist can make eye contact with other users (motorists or otherwise) and decrease the potential for crashes.

<sup>9</sup> AASHTO recommends use of "simple designs that minimize crossing widths and minimize the use of more complex elements such as channelization and separate turning lanes." Source: American Association of State Highway Transportation Officials. "A Policy on Geometric Design of Highways and Streets." 6th ed. (2011): 2-79.

<sup>10</sup> Guéguen, Nicolas, et al. "A pedestrian's stare and drivers' stopping behavior: A field experiment at the pedestrian crossing." Safety Science. June 2015.

## TURN LANES

Right- and left-turn lanes are used to facilitate traffic flow and provide storage for vehicles queued to turn. They also create larger intersections and may add to overall signal cycle length if turning movements have dedicated phases.

## LEFT-TURN LANES

Dedicated left turn lanes benefit motorists by removing left-turn vehicles from through traffic. Separated left turn signal phasing can facilitate turns when gaps in oncoming traffic are infrequent. Left turn lanes also widen intersection crossings. The addition of left turn signal phases can increase the overall delay at a signal for all users. Try to avoid double left turn lanes, which result in even larger intersections, and seek ways to channel traffic to other streets in the network.<sup>11</sup>

## RIGHT-TURN LANES

While it has been common practice in more suburban contexts for intersection designs to channelize vehicles to increase vehicle throughput, designers should avoid channelization at intersections with high pedestrian volumes. Channelized turn lanes are not recommended, but a well-designed slip lane is preferred over a wide curb radius. If right turn lanes are used, they should be designed to limit speeds through the turn. Excess asphalt from turn lanes can be reclaimed to reduce intersection crossing distances and provide additional space for pedestrians. In addition, the use of stop controls and a raised crosswalk on the right-turn slip lane are preferred in order to manage speeds and limit conflicts between pedestrians and motorists.

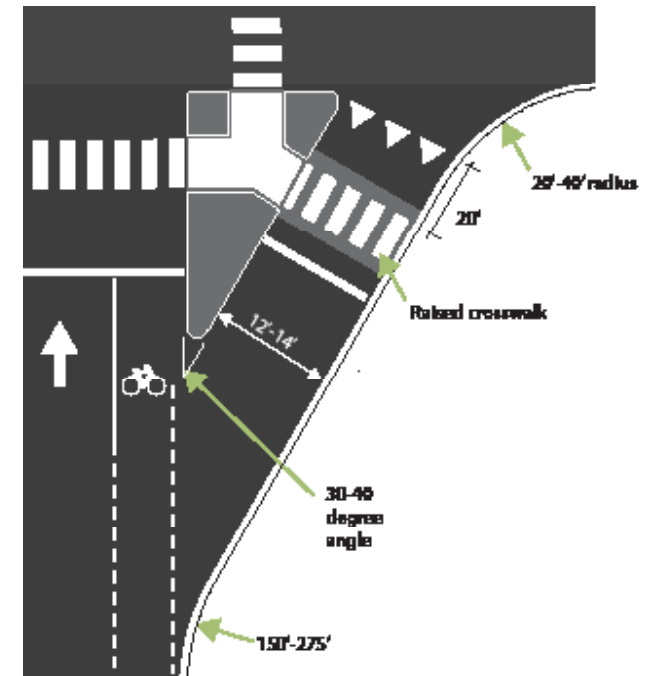

Right Turn Lane – Preferred Design

## MORE INFORMATION

- Federal Highway Administration. “Achieving Multimodal Networks: Applying Design Flexibility and Reducing Conflicts.” 2016.
- Federal Highway Administration. “Road Design: Well Designed Right-Turn Slip Lanes.” <http://safety.fhwa.dot.gov/saferjourney1/library/countermeasures/15.htm>.
- NACTO: Urban Street Design Guide, 2013

<sup>11</sup> The Highway Capacity Manual lists thresholds for dual left turn lanes as 300 vehicles turning left during the peak hour.



## PEDESTRIAN RECALL SIGNALS

Signals that are programmed for “pedestrian recall,” or those that do not require pedestrians to push a button to request to cross the street, are generally preferred in walkable districts. Consistency in these signals throughout the district helps avoid confusion for pedestrians where push button calls may or may not be required to obtain a walk signal. Conventional practice employs actuated pedestrian signals to minimize pedestrian or cross-traffic interference with the flow of traffic in the dominant direction. This makes sense in rural areas with low pedestrian demand, but on multimodal streets where pedestrians are desired, this practice makes pedestrians a secondary user.

### DESIGN POLICIES

- Signals set to pedestrian recall should generally be the rule in areas of pedestrian activity. A walking speed of three feet per second should be used to determine the total crossing time allotted (WALK interval + clearance interval).
- It is recommended that pedestrian recall signals are equipped with accessible pedestrian signals (APS) to ensure ADA and MUTCD compliance, though the walk signal will be called regardless of pressing the actuator.
- Signals can also be synchronized to encourage motorists to adhere to the speed limit. This is critical during off-peak hours.

### MORE INFORMATION

- AASHTO: Guide for the Planning, Design, and Operation of Pedestrian Facilities, 2004
- NACTO: Urban Street Design Guide, 2013

## PEDESTRIAN RECALL SIGNALS

### MODAL PRIORITY



SOURCE: SFMTA

Accessible Pedestrian Signal (APS) – San Francisco, California

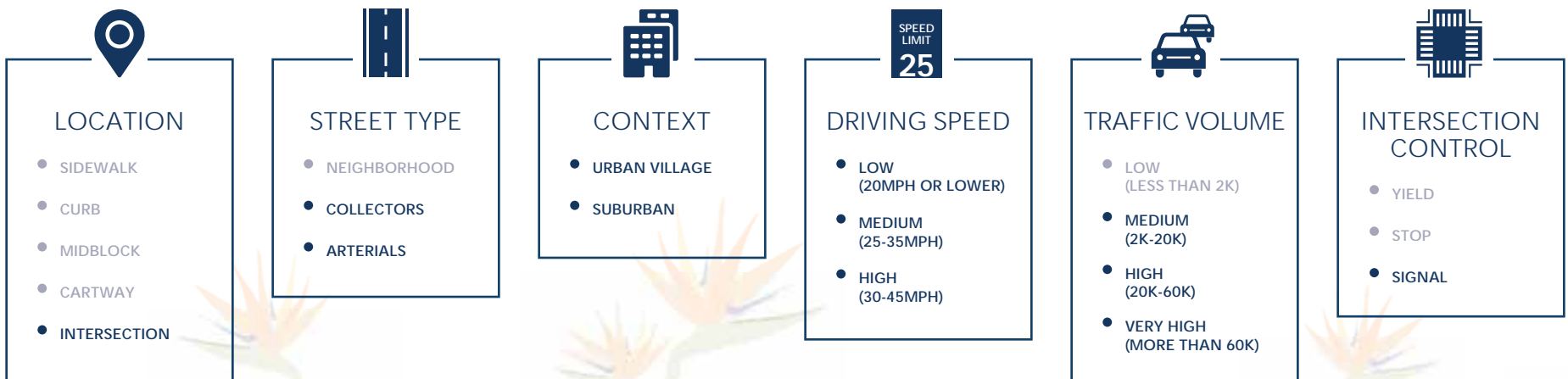



## LEADING PEDESTRIAN INTERVAL

Signals that are programmed for “pedestrian recall,” or those that do not require pedestrians to push a button to request to cross the street, are generally preferred in walkable districts. Consistency in these signals throughout the district helps avoid confusion for pedestrians where push button calls may or may not be required to obtain a walk signal. Conventional practice employs actuated pedestrian signals to minimize pedestrian or cross-traffic interference with the flow of traffic in the dominant direction. This makes sense in rural areas with low pedestrian demand, but on multimodal streets where pedestrians are desired, this practice makes pedestrians a secondary user.

### DESIGN POLICIES

- LPIs require the concurrent use of pedestrian signals, and may not be used with leading left turns.
- LPIs must be a minimum of three seconds in duration, but more commonly provide five or more seconds to permit pedestrians to cross at least one lane of vehicle traffic.
- At locations with extremely high pedestrian volumes, the LPI should be combined with a DON'T WALK signal toward the end of the concurrent green phase for vehicles. This brief period at the end of the cycle provides an opportunity for vehicles to complete turns after the majority of pedestrians have completed their crossing.
- LPIs require the concurrent use of pedestrian signals, and may not be used with leading left turns.
- LPIs should be accompanied by audible and/or vibrotactile signals for visually impaired pedestrians (see APS)
- Combine LPIs with curb extensions to further increase pedestrian visibility and safety. Bicycles may also benefit from LPIs and can use the signal to clear an intersection and facilitate vehicle turns.

### MORE INFORMATION

- AASHTO: Guide for the Planning, Design, and Operation of Pedestrian Facilities, 2004
- NACTO: Urban Street Design Guide, 2013

## LEADING PEDESTRIAN INTERVAL

### MODAL PRIORITY



WALKING



BIKING



TRANSIT



PLACEMAKING



AUTOMOBILE



Leading Pedestrian Interval (LPI) Signal – New Orleans, Louisiana



#### LOCATION

- SIDEWALK
- CURB
- MIDBLOCK
- CARTWAY
- INTERSECTION



#### STREET TYPE

- NEIGHBORHOOD
- COLLECTORS
- ARTERIALS



#### CONTEXT

- URBAN VILLAGE
- SUBURBAN



#### DRIVING SPEED

- LOW (20MPH OR LOWER)
- MEDIUM (25-35MPH)
- HIGH (30-45MPH)



#### TRAFFIC VOLUME

- LOW (LESS THAN 2K)
- MEDIUM (2K-20K)
- HIGH (20K-60K)
- VERY HIGH (MORE THAN 60K)



#### INTERSECTION CONTROL

- YIELD
- STOP
- SIGNAL



## RECTANGULAR RAPID FLASHING BEACON

Rectangular Rapid Flashing Beacons (RRFBs) are devices using LED flashing beacons in combination with pedestrian and bicycle warning signs to provide a high-visibility strobe-like warning to drivers when pedestrians and bicyclists use a crosswalk. RRFBs can be used when a signal is not warranted at an unsignalized crossing. They are not appropriate at intersections with signals or “STOP” signs.



Rectangular Rapid Flashing Beacon (RRFB) Device  
Portland, Oregon

### DESIGN POLICIES

- RRFBs should be placed curbside below the pedestrian crossing sign and above the arrow indication pointing at the crossing at both sides of the roadway.
- RRFBs should be used in conjunction with advance yield pavement lines and pedestrian crossing signs.
- If there is a pedestrian refuge or other type of median, an additional beacon should be installed in the median.
- A push button is used to activate the beacon, or another activation method used by the person to signal the intent to cross. The push button and other components of the crosswalk must meet all other accessibility requirements.
- RRFBs should be limited to locations with critical safety concerns and high volume pedestrian crossings, but may also be considered for priority bicycle route crossings and at locations with high volume pedestrian destinations on either side of a street without a nearby controlled crossing.

### MORE INFORMATION

- AASHTO: Guide for the Planning, Design, and Operation of Pedestrian Facilities, 2004
- NACTO: Urban Street Design Guide, 2013

## RECTANGULAR RAPID FLASHING BEACON

### MODAL PRIORITY



WALKING



BIKING



TRANSIT



PLACEMAKING



AUTOMOBILE



Rectangular Rapid Flashing Beacon (RRFB) Crossing – Solana, California



#### LOCATION

- SIDEWALK
- CURB
- MIDBLOCK
- CARTWAY
- INTERSECTION



#### STREET TYPE

- NEIGHBORHOOD
- COLLECTORS
- ARTERIALS



#### CONTEXT

- URBAN VILLAGE
- SUBURBAN



#### DRIVING SPEED

- LOW (20MPH OR LOWER)
- MEDIUM (25-35MPH)
- HIGH (30-45MPH)



#### TRAFFIC VOLUME

- LOW (LESS THAN 2K)
- MEDIUM (2K-20K)
- HIGH (20K-60K)
- VERY HIGH (MORE THAN 60K)



#### INTERSECTION CONTROL

- YIELD
- STOP
- SIGNAL





## PEDESTRIAN HYBRID BEACON (PHB)

Pedestrian hybrid beacons (PHB) are a traffic control devices used to increase motorist awareness of pedestrian crossings at uncontrolled marked crosswalk locations. The design of a PHB consists of two horizontal red lenses above a yellow lens that remains unlit until the system is activated by a pedestrian with an accessible pushbutton. Once actuated the beacon will flash yellow followed by a steady yellow interval and then a steady red signal indicating motorists need to come to a complete stop at a stop bar marked with signage. Once the pedestrian signal indication switches back to DON'T WALK the beacon will display alternating red lights during the pedestrian clearance interval before going unlit.

### DESIGN POLICIES

- Stop lines and marked crosswalks are required with PHB's. Advanced stop lines should be provided for multi-lane crossings.
- Pedestrian volume thresholds required by the MUTCD are significantly lower for a PHB than a traffic signal and may be implemented in locations where traffic signals are not otherwise warranted.
- To ensure adequate sight distances, on-street parking should be restricted within 100 feet of the crossing for approaching traffic and 20 feet from the crossing on the departure side.

### MORE INFORMATION

- FHWA: Proven Safety Countermeasures, 2017
- FHWA: Pedestrian Hybrid Beacon Guide, 2014
- FHWA: Safety Effectiveness of the HAWK Pedestrian Crossing Treatment, 2010

## PEDESTRIAN HYBRID BEACON (PHB)

### MODAL PRIORITY



WALKING



BIKING



TRANSIT



PLACEMAKING



AUTOMOBILE



SOURCE: INSURANCE INSTITUTE FOR HIGHWAY SAFETY

Pedestrian Hybrid Beacon (PHB) – Phoenix, Arizona



#### LOCATION

- SIDEWALK
- CURB
- MIDBLOCK
- CARTWAY
- INTERSECTION



#### STREET TYPE

- NEIGHBORHOOD
- COLLECTORS
- ARTERIALS



#### CONTEXT

- URBAN VILLAGE
- SUBURBAN



#### DRIVING SPEED

- LOW (20MPH OR LOWER)
- MEDIUM (25-35MPH)
- HIGH (30-45MPH)



#### TRAFFIC VOLUME

- LOW (LESS THAN 2K)
- MEDIUM (2K-20K)
- HIGH (20K-60K)
- VERY HIGH (MORE THAN 60K)



#### INTERSECTION CONTROL

- YIELD
- STOP
- SIGNAL



## PEDESTRIAN SCRAMBLE

A pedestrian scramble, sometimes referred to as a Barnes Dance, is a signal phase that stops all vehicle traffic and allows pedestrians to cross the intersection in any direction, including diagonally. Scrambles are only recommended for use at intersections with significant pedestrian volumes, strong desire lines in all directions, and high turning vehicle volumes. This includes areas similar to where LPIs are appropriate, but should be limited to use in locations where significant conflict exists between the pedestrian and turning vehicle volumes.

### DESIGN POLICIES

- A pedestrian scramble requires implementation of an exclusive pedestrian phase, which should be timed in the same manner as any pedestrian crossing. The time allotted for the scramble phase (WALK interval + clearance interval) must be long enough for a person to travel between the two curb ramps that are farthest apart at a speed of three feet per second.
- It is recommended that diagonal crosswalk markings be installed to establish the space as an official crossing location.

### MORE INFORMATION

- AASHTO: Guide for the Planning, Design, and Operation of Pedestrian Facilities, 2004
- NACTO: Urban Street Design Guide, 2013

## PEDESTRIAN SCRAMBLE

### MODAL PRIORITY



WALKING



BIKING



TRANSIT



PLACEMAKING



AUTOMOBILE



Pedestrian Scramble – Carlsbad



#### LOCATION

- SIDEWALK
- CURB
- MIDBLOCK
- CARTWAY
- INTERSECTION



#### STREET TYPE

- NEIGHBORHOOD
- COLLECTORS
- ARTERIALS



#### CONTEXT

- URBAN VILLAGE
- SUBURBAN



#### DRIVING SPEED

- LOW (20MPH OR LOWER)
- MEDIUM (25-35MPH)
- HIGH (30-45MPH)



#### TRAFFIC VOLUME

- LOW (LESS THAN 2K)
- MEDIUM (2K-20K)
- HIGH (20K-60K)
- VERY HIGH (MORE THAN 60K)



#### INTERSECTION CONTROL

- YIELD
- STOP
- SIGNAL

# PEDESTRIAN CROSSINGS

## CROSSING LOCATIONS

Street crossings are often the most challenging element of pedestrian design. Typical challenges include:

- Existing crosswalks are located  $\frac{1}{4}$  mile apart or further, often times located only at signalized intersections.
- Block spacing is shorter than signal spacing. Since blocks are natural crossing points, people cross between signals. Although every intersection is legally a crosswalk, whether marked or not,<sup>12</sup> not all motorists are aware of this law.
- No marked crossings at trip generators like bus stops and shopping centers.
- Resistance to adding marked crosswalks due to concerns of installation cost, liability, and maintenance.
- Resistance to adding traffic-controlled crosswalks due to concerns over meeting MUTCD warrants.

A pedestrian crossing is the path along which a pedestrian wishes to (or does) travel. This concept is related to pedestrian networks and desire lines. A crosswalk is defined as the extension of the sidewalk across an intersection (whether marked or not). Ideally, crosswalks are matched to crossing locations to provide the most convenient, direct, and comfortable walking environment. Crosswalks can take many forms:

- Unmarked crosswalks are legal crosswalks without any traffic control markings
- Marked crosswalks are legal crosswalks with markings
- Uncontrolled crosswalks are legal crosswalks without stop signs, signals, or other traffic controls
- Controlled crosswalks are legal crosswalks with traffic control



<sup>12</sup> California Vehicle Code §21950

Treatments may vary but must be determined by considering vehicle speed, volume, and roadway configurations. Narrower streets with low volume may not need any formal crosswalks; unmarked, uncontrolled crosswalks may feel safe for all users. Wider, high speed, and high volume roads may require more involved treatments to minimize conflicts between pedestrians and vehicles. These treatments may include medians, overhead signs, improved lighting, and traffic control devices. MUTCD guidance for low-speed streets (35 mph and under) follow FHWA’s “Safety Effects of Marked versus Unmarked Crosswalks” for the treatment of marked, uncontrolled crosswalks.

## GUIDELINES FOR CROSSWALK INSTALLATION AT UNCONTROLLED LOCATIONS ON STREETS WITH SPEED LIMIT OF 35MPH OR BELOW

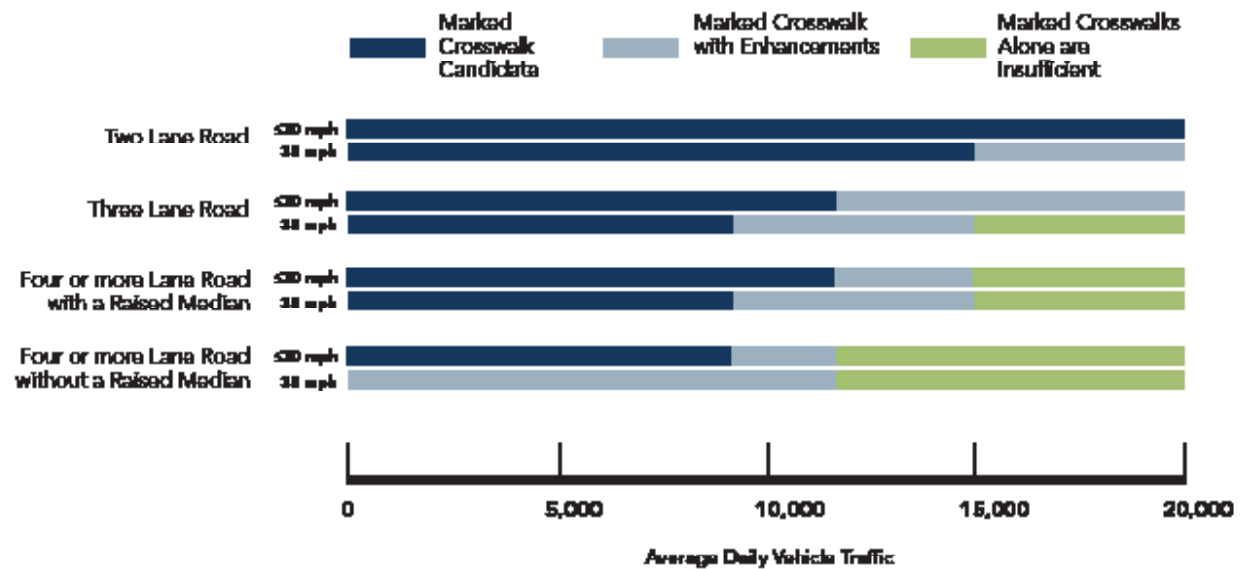

Uncontrolled Crossing Precedents

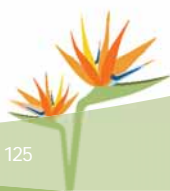



## MARKED CROSSWALK

A marked crosswalk is any portion of a roadway at an intersection or elsewhere that is distinctly indicated for pedestrian crossing by lines or other markings on the surface. Marked crosswalks are critical components that facilitate a connected and continuous pedestrian network. Marked crosswalks may occur at either intersections or at mid-block locations between intersections. While pedestrians are legally permitted to cross at the intersection of two or more streets, whether the crossings are marked or unmarked, marked crosswalks should be provided at all significant pedestrian crossing locations. Also consider installing marked crosswalks near schools, parks, and community facilities, depending on adjacent street type and expected or observed pedestrian demand.

### MORE INFORMATION

- AASHTO: Guide for the Planning, Design, and Operation of Pedestrian Facilities, 2004
- NACTO: Urban Street Design Guide, 2013

### DESIGN POLICIES

- At intersections with marked crosswalks, crosswalks should be provided across all legs.
- Pedestrians should not be forced into out-of-direction travel due to missing crosswalks.
- Marked and unmarked crossings should be adequately lit to provide safety and visibility for both pedestrians and motorists. Crossing distance should be as short as possible to minimize exposure and risk.
- Continuous crossings in excess of 44 feet in length should be avoided. For crossings greater than 44 feet, consider using pedestrian refuge islands.
- Because of the low approach angle at which pavement markings are viewed by drivers, the use of longitudinal markings in addition to or in place of transverse markings can significantly increase the visibility of a crosswalk to oncoming traffic. The Federal Highway Administration notes that high-visibility pedestrian crosswalks. (such as the longitudinal marking) have a positive effect on pedestrian and driver behavior.

### MINIMUM PREFERRED DIMENSIONS

Crosswalks should be as wide or wider than the sidewalks they connect, but at least six feet wide. Ten feet in width is preferred.

## MARKED CROSSWALK

### MODAL PRIORITY



Marked Crosswalk – Solana, California



#### LOCATION

- SIDEWALK
- CURB
- MIDBLOCK
- CARTWAY
- INTERSECTION



#### STREET TYPE

- NEIGHBORHOOD
- COLLECTORS
- ARTERIALS



#### CONTEXT

- URBAN VILLAGE
- SUBURBAN



#### DRIVING SPEED

- LOW (20MPH OR LOWER)
- MEDIUM (25-35MPH)
- HIGH (30-45MPH)



#### TRAFFIC VOLUME

- LOW (LESS THAN 2K)
- MEDIUM (2K-20K)
- HIGH (20K-60K)
- VERY HIGH (MORE THAN 60K)



#### INTERSECTION CONTROL

- YIELD
- STOP
- SIGNAL





## MEDIAN REFUGE ISLAND

While pedestrians will always find it more convenient to cross the street in one stage, median refuge islands are a tool to improve pedestrian safety in areas where automobile movement has been prioritized. Refuge islands are raised sections within the roadway that provide a safe landing zone for people walking and bicycling to use while crossing a street with multiple travel lanes. Median pedestrian and bicycle refuge islands make roadway crossings easier and safer by 1) limiting exposure to through moving vehicles; 2) enabling crossings to commence when there are gaps in traffic from one direction at a time; and 3) providing a safe stopping place in the middle of the roadway for pedestrians who are not able to make the complete street crossing during a pedestrian signal phase. They may be used at signalized and unsignalized intersections or mid-block.

### MORE INFORMATION

- AASHTO: Guide for the Planning, Design, and Operation of Pedestrian Facilities, 2004
- Federal Highway Administration: Small Town and Rural Multimodal Networks, Chapter 2: Mixed Traffic Facilities
- NACTO: Urban Street Design Guide, 2013

### DESIGN POLICIES

- Pedestrian refuge islands are most often used on multi-lane roadways where a pedestrian must cross 44 feet or more of continuous roadway or where they are necessary to provide a safe crossing.
- Pedestrian refuge islands may be used as a traffic calming or traffic channelization device, often in concert with mini roundabouts or acute angle right turns.

### MINIMUM PREFERRED DIMENSIONS

Pedestrian refuge islands should be a minimum of eight feet deep, and preferably 10, in order to comfortably accommodate single pedestrians, pedestrians with strollers or assisted mobility devices, or pedestrians with bicycles.

## MEDIAN REFUGE ISLAND

### MODAL PRIORITY



SOURCE: CONGRESS FOR NEW URBANISM

Median Refuge – San Diego, California



#### LOCATION

- SIDEWALK
- CURB
- MIDBLOCK
- CARTWAY
- INTERSECTION



#### STREET TYPE

- NEIGHBORHOOD
- COLLECTORS
- ARTERIALS



#### CONTEXT

- URBAN VILLAGE
- SUBURBAN



#### DRIVING SPEED

- LOW (20MPH OR LOWER)
- MEDIUM (25-35MPH)
- HIGH (30-45MPH)



#### TRAFFIC VOLUME

- LOW (LESS THAN 2K)
- MEDIUM (2K-20K)
- HIGH (20K-60K)
- VERY HIGH (MORE THAN 60K)



#### INTERSECTION CONTROL

- YIELD
- STOP
- SIGNAL



## CURB EXTENSIONS

A curb extension is a section of sidewalk or landscaped area extending into the roadway at an intersection or mid-block crossing that physically narrows the roadway. They are used to create safer, shorter crossings for pedestrians; slow traffic speeds; and/or increase pedestrian zone space for street furniture, benches, landscaping, and street trees. Regardless of street type, curb extensions may only be used where a curb lane is present and used for parking or loading, not travel. Curb extensions are particularly beneficial in commercial frontage contexts where pedestrian volumes are high, where traffic calming is desired, and on very wide streets.

### DESIGN POLICIES

- Curb extensions should not narrow any bike or general traffic lanes to an unsafe width.
- Extensions should preserve one to two feet of shy distance between the curb face and the first travel lane or bicycle lane.
- When applied to streets with on-street parking, they are typically six to seven feet wide; alternatively, extensions can shadow the length of the parking stall, if parking is on the diagonal.
- Corner or mid-block extensions with crosswalks should be at least as wide as the crosswalk, and ideally extend to the stop bar. The curve of the extension must fit outside of any crosswalks.
- Extensions are intended to narrow pedestrian crossing distance and slow traffic speeds. To accomplish this, maintain tight turning radii no greater than 20 feet. The effective turning radius may be wider.

### MORE INFORMATION

- AASHTO: Guide for the Planning, Design, and Operation of Pedestrian Facilities, 2004
- NACTO: Urban Street Design Guide, 2013

## CURB EXTENSIONS

### MODAL PRIORITY



SOURCE: COMPLETE STREETS NM

Curb Extension – Albuquerque, New Mexico



#### LOCATION

- SIDEWALK
- CURB
- MIDBLOCK
- CARTWAY
- INTERSECTION



#### STREET TYPE

- NEIGHBORHOOD
- COLLECTORS
- ARTERIALS



#### CONTEXT

- URBAN VILLAGE
- SUBURBAN



#### DRIVING SPEED

- LOW (20MPH OR LOWER)
- MEDIUM (25-35MPH)
- HIGH (30-45MPH)



#### TRAFFIC VOLUME

- LOW (LESS THAN 2K)
- MEDIUM (2K-20K)
- HIGH (20K-60K)
- VERY HIGH (MORE THAN 60K)



#### INTERSECTION CONTROL

- YIELD
- STOP
- SIGNAL

## ADA COMPLIANCE

Cities are legally bound to meet certain standards to be ADA compliant. Title II of the ADA requires public entities to ensure that all their programs, activities, and services—including their public rights-of-way—are accessible to and useable by individuals with disabilities. These standards apply to all new construction and retrofits of existing facilities to ensure equal access. Any non-compliant sidewalks or curb ramps must be upgraded to meet current standards whenever any alterations, such as road surfacing, are carried out. Key requirements include:

- Curb ramps located wherever a sidewalk crosses a curb, whether they are at intersections (marked or unmarked) or midblock locations.
- Curb ramps designed with specific dimension and slope as identified in the 2010 ADA Standards for Accessible Design. Ramps must have a slope of less than 1:12 and must be at least 3 feet wide.

- Locations for crossing the street should be legible for those with visual disabilities using detection features such as truncated domes, contrasting color, and crossing edges.
- Curb ramps should be located so that they do not project into vehicular traffic lanes, parking spaces, or parking access aisles. Curb ramps at marked crossings should be wholly contained within the markings, excluding any flared sides.
- Raised median islands in crossings should be cut through level with the street or have curb ramps at both sides.

## MORE INFORMATION

- MUTCD, 2009: Section 9C.04, Markings For Bicycle Lanes
- NACTO Urban Bikeway Design Guide. Intersections.

# DRAFT

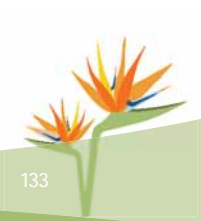
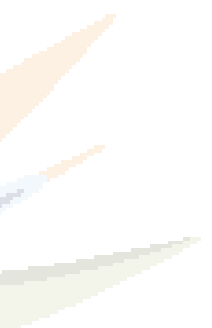



# 9 IMPLEMENTATION





# 9 IMPLEMENTATION

The preceding chapters provide guidance for the design of safe and complete street elements in Carlsbad across a variety of topics. However, the problems that City staff are asked to address are seldom as simple as “What are the dimensions of a parklet?” Rather, staff are normally asked questions such as “How do we cut down on speeding?” or “Can’t we add a signal to make crossing the street safer?” or statements like “We need better bike connections.” Answering these types of questions effectively require staff to consider various elements covered throughout this guide in conjunction with one another and in consideration of community intent and opinion.



## TRADEOFFS

In many cases, the design of an ideal street is constrained by the width of the available right-of-way. The street context and modal emphasis networks presented in this design guide should be used to weigh tradeoffs and inform the selection of an appropriate cross section when retrofitting a street or when building a new street. Examples of potential tradeoffs include: choices between wider sidewalks or a wider roadway; meeting the needs of trees or the needs of transit; providing bicycle facilities or providing on-street parking. Important elements to consider in balancing priorities:

- Is there a modal emphasis designated for that street?
- What is the context of the street; is it in an urban village area or suburban area?
- What are the physical constraints; is the ROW limited, are there mature trees to save, etc.?
- What are the constraints on the project; is it just a resurfacing, are there budgetary constraints, etc.?
- What are the impacts and constraints on public or private properties?
- What input has the community provided?

Several case study scenarios of constrained corridors and competing priorities are presented below along with guidance on how the design team might consider and identify the appropriate design for the street.



# OVERCOMING BICYCLE OBSTACLES

## POINSETTIA AT BATIQUITOS

### PROBLEM STATEMENT

A wide fast street and the presence of obstacles such as freeway ramps make this a daunting corridor for most people who would consider riding a bike.

### KNOWN CONSTRAINTS:

- While the corridor has a current attached bike lane, the high speed traffic is not comfortable for most potential bike riders.
- Drainage and utilities along the curblines would make any widening expensive.
- Navigation across the I-5 Interchange is even more challenging and does not feel safe to most potential users.

### KEY TECHNICAL GUIDANCE:

- Facility Selection Guidance, 58
- Design Considerations for Bikeway Segments, 71
- Design Considerations for Intersections, 75
- Road Diets, 9

### EXISTING CROSS SECTION:

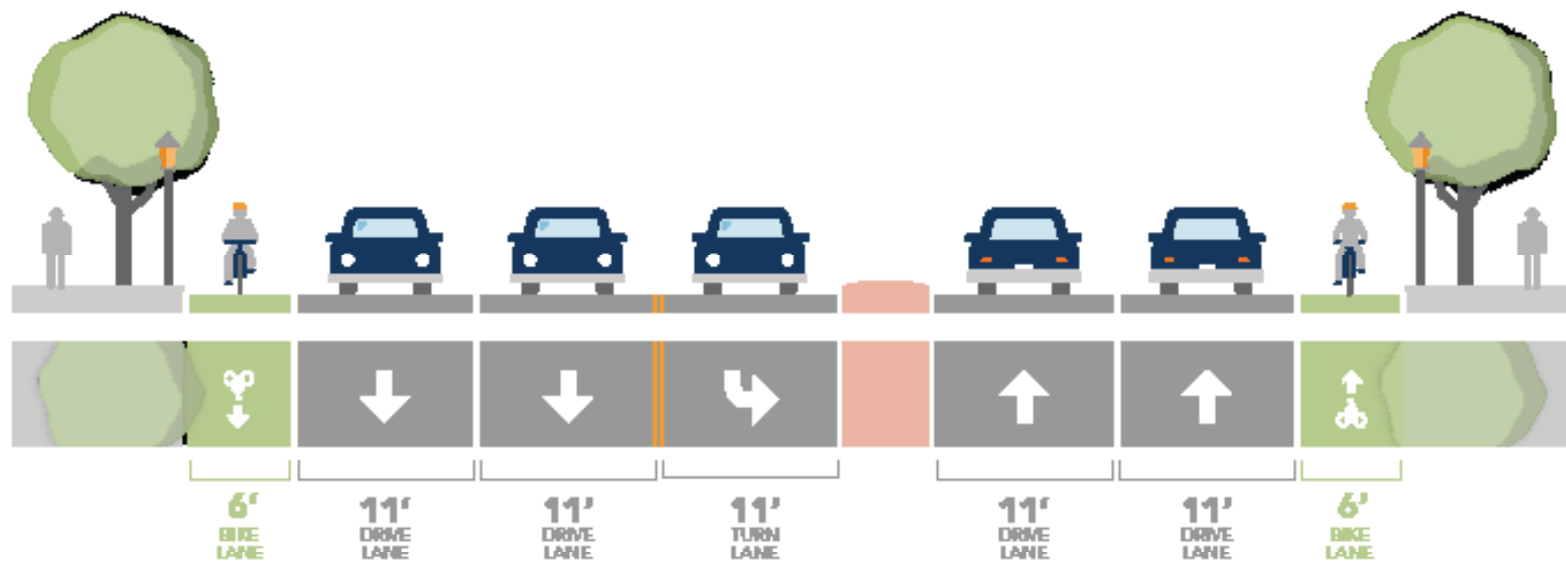

## OPTIONS CONSIDERED:

### OPTION 1: CONVERT DRIVING LANES

#### PROS:

Conversion of two driving lanes to make space for buffered bike lanes would represent the lowest cost and fastest approach to creating a comfortable 8-80 facility.

#### CONS:

While traffic volumes on the corridor do not rule out reducing the number of driving lanes on Poinsettia, it is one of a limited number of east-west corridors and capacity reductions would likely be contentious. This would likely be a last resort for this corridor.

### OPTION 2: WIDEN CURB-TO-CURB CROSS-SECTION

#### PROS:

This option would allow the development of a tailored, 8-80 bike facility while preserving automobile capacity.

#### CONS:

High cost of moving curbs and redoing utilities (including drainage).

### OPTION 3: REDUCE LANE WIDTHS/ REDUCE MEDIAN

#### PROS:

Given the cost constraints and likely community pushback to automobile capacity reduction, this would appear the best option for creating a strong, east-west, low-stress bicycle facility.

#### CONS:

This project will still involve some cost of resurfacing and median modification, though higher cost utility and right-of-way impacts would be avoided.

## FINAL DESIGN:

In the end, a project such as this which involves some manageable costs will be undertaken if this is determined to be a key corridor for a low-stress bike connection.

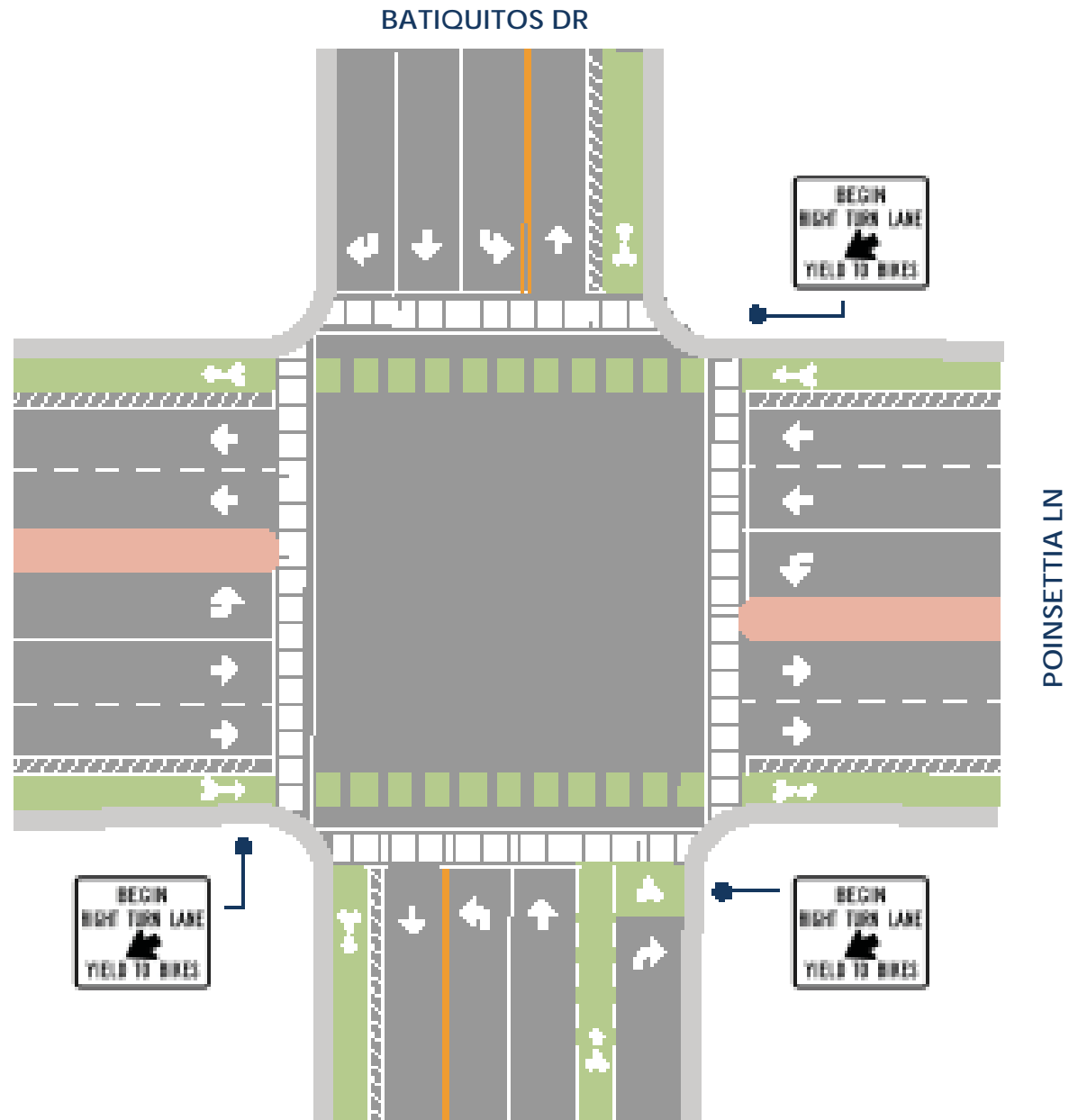

# ARTERIAL SPEED MANAGEMENT/SAFE CROSSING

## CARLSBAD BOULEVARD

### PROBLEM STATEMENT

This street is crossed frequently by pedestrians going to the beach, but people do not feel safe crossing due to the width and the speed of some cars. Currently, the separated crossings are too far apart to be considered convenient by most pedestrians.

### EXISTING CROSS SECTION:

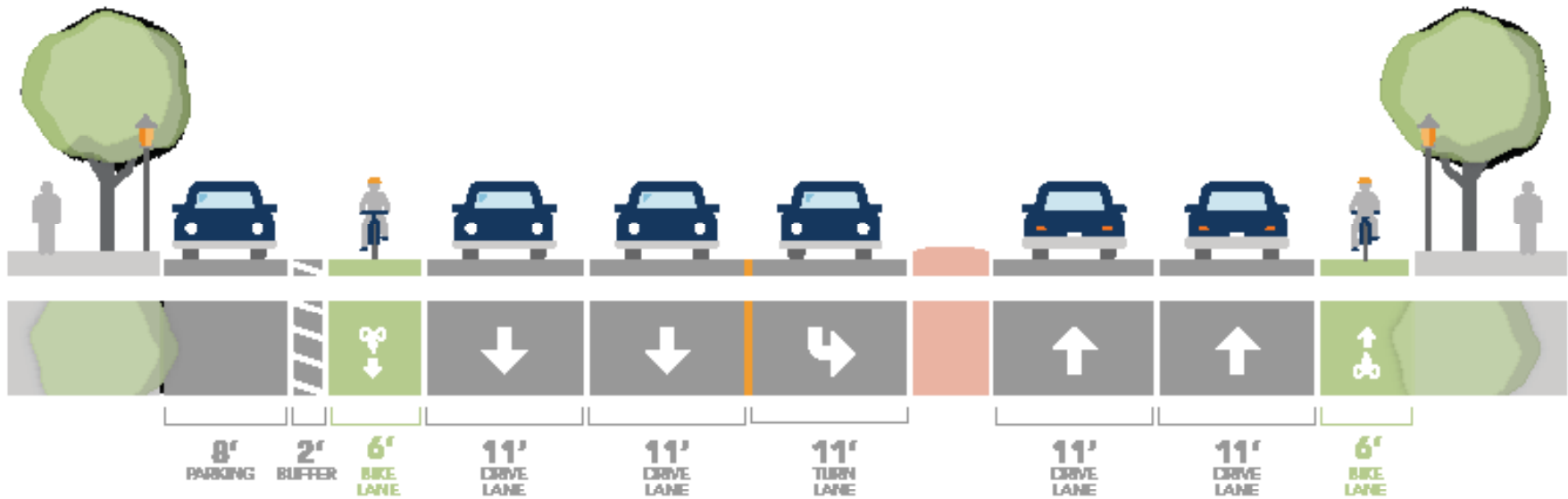

### KNOWN CONSTRAINTS:

- Variable curb-to-curb width along corridor
- Significant landscaping and utilities in sections of the median

### KEY TECHNICAL GUIDANCE:

- Arterial Speed Management, 98
- Compact Intersections, 115
- Rectangular Rapid Flashing Beacon, 124
- Pedestrian Hybrid Beacon, 126
- Pedestrian Crossings, 128

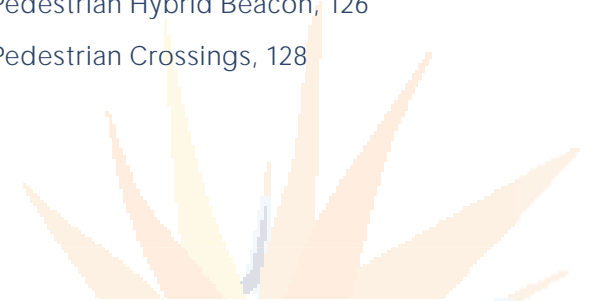

## OPTIONS CONSIDERED:

**OPTION 1:****CONVERT FROM 5 TO 3 DRIVING LANES****PROS:**

Conversion of two driving lanes would narrow the crossings and slow traffic to the point that unsignalized crosswalks could be considered. This would be done using the logic that Carlsbad Boulevard is paralleled by Interstate 5 which is a more appropriate corridor for long distance travel.

**CONS:**

While traffic volumes on the corridor do not rule out reducing the number of driving lanes on Carlsbad Boulevard, its role in beach access and friction caused by on-street parking along parts of the corridor would likely make such a change contentious. This would likely be a last resort for this corridor.

**OPTION 2:****ADD VERTICAL ELEMENTS TO REDUCE DRIVING****PROS:**

More vertical elements directly along the curbline (trees, street lighting, benches, etc.) and in the median would help to narrow the view and create a sense of enclosure. These types of urban treatments are associated with drivers choosing lower travel speeds.

**CONS:**

An enclosed, urban feel is likely not in keeping with the character of this section and may not be supported by residents and stakeholders. The speed reductions achieved from this change also may not be significant enough to make street crossings feel materially safer.

**SPEEDS****OPTION 3:****ADD RAPID FLASHING BEACONS OR PEDESTRIAN SIGNALS TO FACILITATE MORE FREQUENT CROSSINGS**

Adding active control for pedestrian crossings would create more frequent, safe crossings without significantly diminishing automobile capacity. For locations deemed appropriate for RFBs, the cost would be low.

**CONS:**

Drivers may consider additional signals a nuisance.

## DESIGN DETAILS CONSIDERED:

**TIGHTER CURB  
RETURN RADII, ADA  
ACCOMMODATIONS AT  
INTERSECTIONS****PROS:**

Reducing the large, sweeping curb radii along the corridor would cause right turning drivers to reduce their speeds, lowering speeds along the corridor overall. Assuring accessible, ADA compliant intersections is also the proper approach.

**CONS:**

There is some cost involved in this measure, so it would make sense to prioritize the intersections where ADA upgrades are needed.

## FINAL DESIGN:

Adding signalized crossings at a reasonable spacing (perhaps every 600 feet in areas with land uses along the corridor), would create a safer and more comfortable environment for pedestrians and bicyclists. Consider signals and crosswalks where islands already exist.

# TRANSIT STREET

## EL CAMINO REAL AT ALGA ROAD

### PROBLEM STATEMENT

The street is a primary transit corridor but lacks elements to prioritize transit use at some stop locations.

### KNOWN CONSTRAINTS:

- Inconsistent stop amenities and configurations along corridor
- Drainage and bike lane along curb line

### KEY TECHNICAL GUIDANCE:

- Bus Passenger Waiting Area,
- Bus Loading Zone, 40
- Bus Bulb, 42
- Bus Priority Treatments, 105

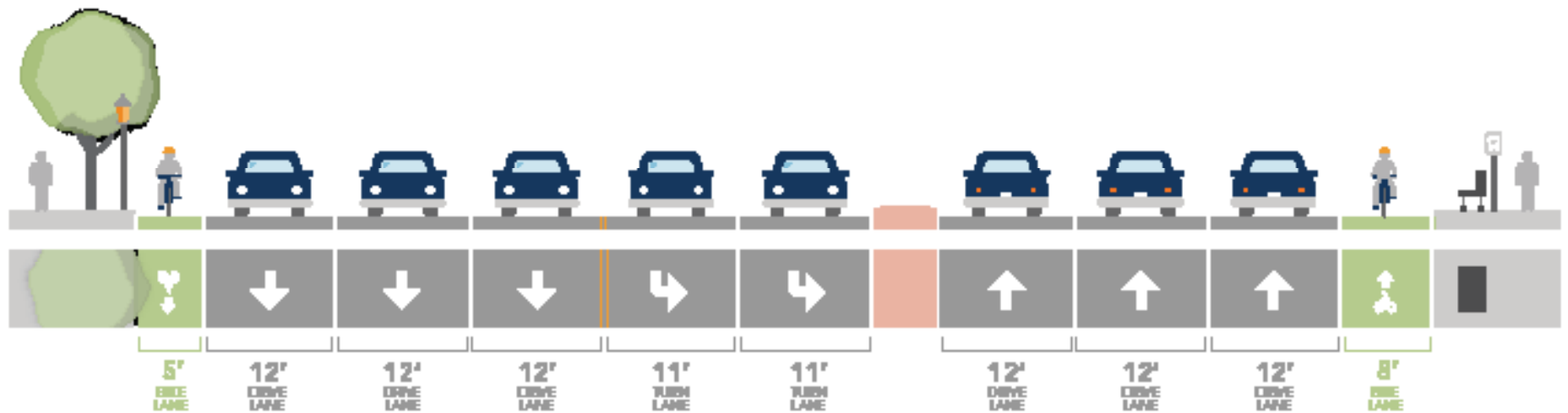



## OPTIONS CONSIDERED:

**OPTION 1:****CONVERT A TRAVEL LANE TO A DEDICATED TRANSIT LANE****PROS:**

Dedicated transit lanes improve on-time performance and transit efficiency by providing buses with a prioritized space over other modes.

**CONS:**

Dedicated transit lanes are recommended where transit service is frequent (headways of ten minutes or less) and traffic congestion significantly interferes with transit operations, which are not identified issues along the corridor.

**OPTION 2:****INSTALL A BUB BULB****PROS:**

Bub bulbs allow transit vehicles to make in-lane stops, reducing transit delay, while providing increased space for passenger amenities and boarding.

**CONS:**

The presence of an existing bike lane raises a significant challenge for implementing a bus bulb. Redirecting bike lanes behind a bus bulb can eliminate this issue however this solution is space intensive, and there is likely not enough transit service or bicycle ridership on this corridor to warrant the adjustments that would be needed to accomplish this solution.

**OPTION 3:****INSTALL BUS SHELTER****PROS:**

Bus shelters improve passenger experience.

**CONS:**

Existing sidewalk width may require encroachment on property line to install pad and shelter.

DESIGN DETAILS CONSIDERED:

## RAISED BUS PLATFORM

### PROS:

Removes conflict between buses and bicyclists, allows buses to stop without pulling in and out of traffic, and provides increased space for passengers to board and alight.

### CONS:

Still being piloted in major cities and requires new signage and user education.

FINAL DESIGN:

Adding a bus shelter to increase passenger experience would be an easy to implement solution that would provide the greatest benefit to transit users. Coupling this improvement with a raised bus platform would prioritize transit operations by eliminating the need for buses to reenter traffic while providing an uninterrupted facility for bicyclists.



SOURCE: STREETS BLOG LA

Bike Lane Accommodating Bus Platform — Los Angeles, California

*Appendix D*

**D**

**SMP COMMUNICATIONS  
PLAN**



# DRAFT Communication and Outreach Plan for the City Sustainable Mobility Program

*July 10, 2018*

## OVERVIEW

This strategic plan provides guidance and support for communication and public outreach activities for the **City of Carlsbad Sustainable Mobility Program (SMP)**. This plan provides a framework for city leaders, managers and staff, program partners, project staff and consultants in communicating with and outreaching to Carlsbad residents and businesses, the general public, community leaders, elected officials and media about the City of Carlsbad Sustainable Mobility Program in 2018.

This plan also seeks a two-way communication mechanism for impacted communities and interested members of the public to provide input to the City as we continue to foster overall trust and credibility on behalf of the city within the communities, businesses and stakeholders served.

### **The following sections are outlined in this DRAFT plan:**

- I. Public Engagement and Outreach Goals
- II. Communications Strategy
- III. Brand and Key Messages
- IV. Stakeholders and Target Audiences
- V. Outreach Tactics and Activities
- VI. Informational Tools and Toolkit
- VII. Schedule



July 10, 2018

## I. PUBLIC ENGAGEMENT AND OUTREACH GOALS

The goal of community outreach is to share project information, identify any community issues or concerns that the Carlsbad Sustainable Mobility Program team needs to address and to regularly provide information to impacted communities and to the broader target audience.

**The public engagement goals below expand from the stated goal in the Carlsbad Coastal Mobility Readiness Plan:** *To create an innovative transportation future in which advanced information, new technologies and sustainable fuels support a vibrant community with seamless mobility options.*

The plan described itself as building upon *“the notion that people will have greater options to get to work, get to their homes, and how they will have a greater connection throughout coastal Carlsbad and the Village of Carlsbad for recreation and leisure.”*

1. Educate stakeholders so that they understand the SMP need, purpose, benefits, process and opportunities to become engaged and provide feedback. Convey project goals and key messages, clearly, accurately, coherently and consistently.
2. Design and implement engaging activities to provide clear and easily accessible opportunities for community input about the SMP.
3. Utilize information provided through meaningful public engagement to develop context-specific mobility solutions for Carlsbad communities. Compile public input and use it to inform the purpose and design of the final plan.
4. Expand defined stakeholders and inform and educate them on the benefits and needs of the Sustainable Mobility Program.
5. Build relationships with critical partners that can help engage the public and reinforce the benefits of the program.
6. Engage the community as program options are developed and work to maintain participation in and support of the process through all phases.



July 10, 2018

## II. COMMUNICATIONS STRATEGY

The Sustainable Mobility Program team is clear in the importance of conducting community outreach to achieve overall City mobility goals. This strategy detailed in this plan includes extensive community outreach and participation through a cohesive brand and targeted messaging presented through engaging and modern digital platforms (website, mobile, social media, video) as well as a survey, attendance at community events. Additional targeted outreach will be conducted for local schools and specific communities based on transportation interest, impact and needs.

Below are key strategies that will help us achieve the overall goals and objectives in this plan. A Work Plan Schedule will be developed to be approved by the City and program team. Our core strategy is outlined below:

- 1. Clarity and consistency:** We need to have clarity on the program naming conventions and outreach process and consistently use this terminology in all written and verbal communication. The branded name / logo can utilize the program name as a subset or tagline.
- 2. Concise and easy to follow:** We will develop compelling core messaging for the community at large that can be conveyed in a brief introductory sentence or short social media post, and then be supported in FAQs, fact sheets, event boards and personal explanations.
- 3. Target-specific:** While we will develop overall, City-wide messaging for this effort, we must also be target-specific with outreach material for community members and stakeholders as we conduct personal outreach in specific neighborhoods and with specific groups. We need to determine when to begin in-person outreach based on when program technical data is clear and if/how location-specific information is available.
- 4. Multiple communication channels:** We will combine traditional and emerging digital platforms and community meetings. We will also utilize traditional media, social media and local business and industry groups to reach the public (City Facebook pages, Twitter accounts, Instagram, etc).
- 5. Engagement:** We will engage the community where they are, and not rely solely on residents attending a community meeting. By reaching out to influencers with personal outreach at community meetings, events, and handing out material at specific high-touch locations in the area (street corners and community meetings/events) we will increase engagement.



*July 10, 2018*

**Below are specific strategic tasks to help achieve overall goals and objectives for this program:**

1. Conduct assessment and research of existing plans/surveys.
2. Finalize the program stakeholder list.
3. Develop uniform messaging that includes an updated program name and graphic design elements.
4. Implement the campaign focused on stakeholder working groups and community meetings/events.
5. Amplify engagement via digital tools and social media.
6. Track and measure results to adjust activities if/as needed.

Multiple skills and resources are available to the program team, including public outreach strategy and implementation led by the NV5 team, stakeholder facilitation and skills provided by MIG practitioners, and subject matter experts from Circulate San Diego and the San Diego County Bicycle Coalition, who will support the outreach efforts and provide expertise in SRTS and bicycle education/encouragement programs.

The strategies outlined in this plan will also help to adhere to City communication and brand standards, to manage community expectations, avoid misunderstandings, and honor commitments made by the program team.



July 10, 2018

**Existing Assets:**

1. Carlsbad Community Vision  
<http://www.carlsbadca.gov/services/depts/planning/update/values.asp>  
<http://www.carlsbadca.gov/civicax/filebank/blobdload.aspx?BlobID=23293>  
\*Need updated Vision Document (see image)

2. Carlsbad Core Values and Council Goals  
<http://www.carlsbadca.gov/services/depts/planning/update/values.asp>

**Become a leader in multimodal transportation systems and creative approaches to moving people and goods through and within Carlsbad.**

3. Carlsbad General Plan  
<http://www.carlsbadca.gov/services/depts/planning/general.asp>
4. General Plan Mobility Element  
<http://www.carlsbadca.gov/civicax/filebank/blobdload.aspx?BlobID=24065>
5. Sustainable Mobility Plan
6. Climate Action Plan  
<http://www.carlsbadca.gov/civicax/filebank/blobdload.aspx?BlobID=29361>
7. Transportation Demand Management (TDM) Program  
<http://www.sandag.org/index.asp?projectid=19&fuseaction=projects.detail>
8. Carlsbad Active Transportation Plan





July 10, 2018

9. Pedestrian Master Plan  
<http://www.carlsbadca.gov/services/depts/pw/traffic/biking.asp>
  
10. Trails Master Plan  
<http://www.carlsbadca.gov/civicax/filebank/blobdload.aspx?BlobID=33168>
  
11. Bike Master Plan  
<http://www.carlsbadca.gov/services/depts/pw/traffic/biking.asp>
  
12. Complete Streets Act of 2009  
<https://www.congress.gov/bill/111th-congress/house-bill/1443>
  
13. City Website and/or/plus Project Website:  
<http://www.carlsbadca.gov/services/depts/pw/traffic/mobility.asp>  
  
<http://carlsbadlifeinaction.com/live/transportation-links/>
  
14. Mobility Element Document:  
<http://www.carlsbadca.gov/civicax/filebank/blobdload.aspx?BlobID=24065>
  
15. Carlsbad Coastal Mobility Readiness Plan (Jan 2016) – With the “Park Once” campaign  
<http://www.carlsbadca.gov/civicax/filebank/blobdload.aspx?BlobID=33108>
  
16. Project Name: TBD
  
17. Collateral materials (printed/digital)
  
18. Video (use b-roll from below for custom video vignettes):  
<https://www.youtube.com/channel/UCEpvrViEk8vH3AzLg5IEo8A>

July 10, 2018





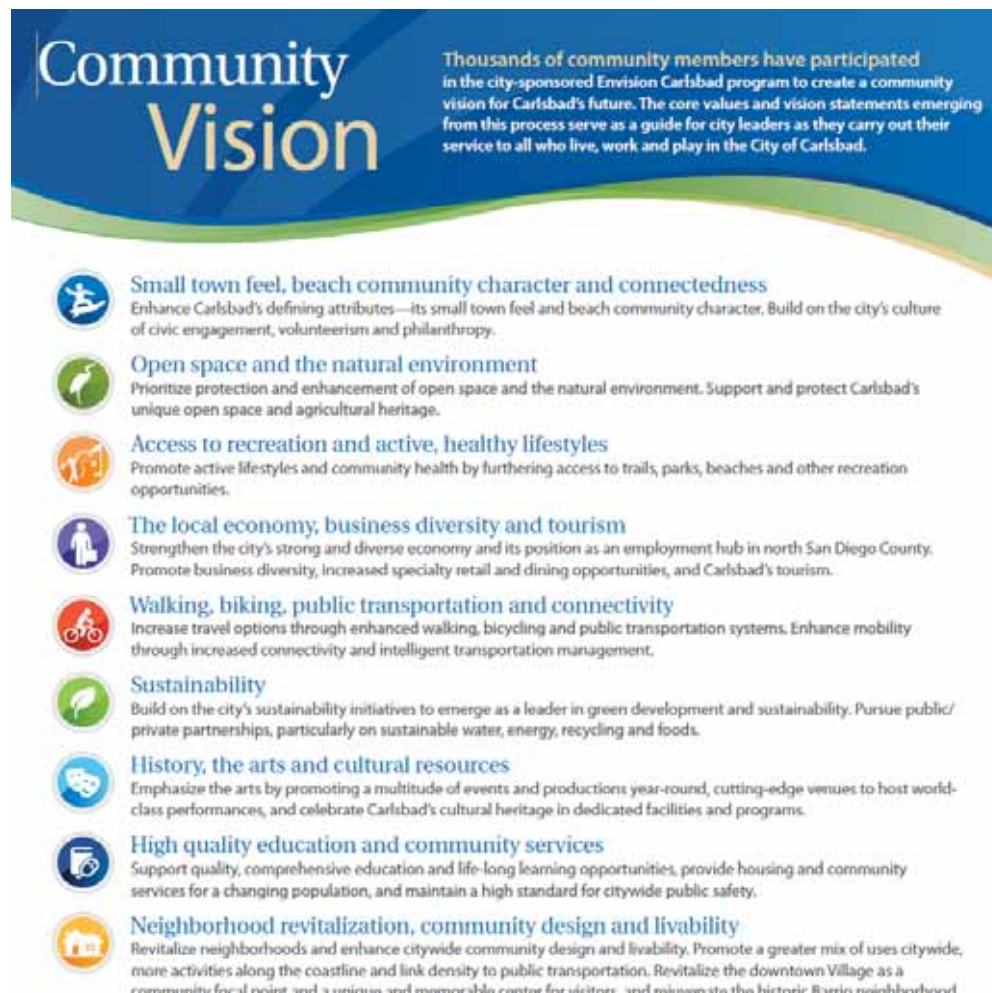



19. Social Media: (determine project-specific hashtag and/or social media handles)

- <https://www.facebook.com/cityofcarlsbad/>
- <https://www.facebook.com/Carlsbadbiz>
- <https://www.facebook.com/carlsbadcitylibrary>
- <https://www.facebook.com/CarlsbadPoliceDepartment/>
  
- <https://twitter.com/carlsbadcagov>
- <https://twitter.com/Carlsbadbiz>
- <https://twitter.com/carlsbadlibrary>
- <https://twitter.com/CarlsbadPolice>



**Community Vision**

Thousands of community members have participated in the city-sponsored Envision Carlsbad program to create a community vision for Carlsbad's future. The core values and vision statements emerging from this process serve as a guide for city leaders as they carry out their service to all who live, work and play in the City of Carlsbad.

-  **Small town feel, beach community character and connectedness**  
 Enhance Carlsbad's defining attributes—its small town feel and beach community character. Build on the city's culture of civic engagement, volunteerism and philanthropy.
-  **Open space and the natural environment**  
 Prioritize protection and enhancement of open space and the natural environment. Support and protect Carlsbad's unique open space and agricultural heritage.
-  **Access to recreation and active, healthy lifestyles**  
 Promote active lifestyles and community health by furthering access to trails, parks, beaches and other recreation opportunities.
-  **The local economy, business diversity and tourism**  
 Strengthen the city's strong and diverse economy and its position as an employment hub in north San Diego County. Promote business diversity, increased specialty retail and dining opportunities, and Carlsbad's tourism.
-  **Walking, biking, public transportation and connectivity**  
 Increase travel options through enhanced walking, bicycling and public transportation systems. Enhance mobility through increased connectivity and intelligent transportation management.
-  **Sustainability**  
 Build on the city's sustainability initiatives to emerge as a leader in green development and sustainability. Pursue public/private partnerships, particularly on sustainable water, energy, recycling and foods.
-  **History, the arts and cultural resources**  
 Emphasize the arts by promoting a multitude of events and productions year-round, cutting-edge venues to host world-class performances, and celebrate Carlsbad's cultural heritage in dedicated facilities and programs.
-  **High quality education and community services**  
 Support quality, comprehensive education and life-long learning opportunities, provide housing and community services for a changing population, and maintain a high standard for citywide public safety.
-  **Neighborhood revitalization, community design and livability**  
 Revitalize neighborhoods and enhance citywide community design and livability. Promote a greater mix of uses citywide, more activities along the coastline and link density to public transportation. Revitalize the downtown Village as a community focal point and a unique, well-maintained center for visitors and residents in the historic Bixby neighborhood.



July 10, 2018

### III. KEY MESSAGES

One of the first tasks will be development of unifying messaging for this program. As information is shared with stakeholders and the public, an overarching name for the City's efforts and community vision related to transportation could be created. All graphics as well as text usage guidelines that are within the City of Carlsbad established branding guidelines.

We will reduce jargon and easily confusing terminology for the general public (sustainable mobility vs mobility readiness, etc).

Key messages will also be developed to support the brand and clarify the program effort. These messages will differ depending on the audience and understanding of Carlsbad transportation projects, goals and programs. Tailored speaking points will be developed for each community presentation and media interview opportunity. Media speaking points should contain ideally three, but up to five key messages, including one call to action, such as "visit our website" "take our survey" or "come see for yourself at a community event."

The following key messages will be maintained and reinforced throughout all communications efforts.

The Carlsbad Sustainable Mobility Program (SMP) expands our city's network of smart travel options. As we continue to grow this network, we empower all residents with choices that improve commuting, recreation and getting around our city overall, while accomplishing these important benefits:

1. Increased safety
2. More convenient options
3. Healthier travel options
4. Better traffic flow

Through the SMP, Carlsbad continues to evaluate, adjust, plan, design, and expand to continually offer better options that uphold our Community Vision.



July 10, 2018

#### IV. STAKEHOLDERS AND TARGET AUDIENCES

The target audience for outreach efforts for the Sustainable Mobility Program Communication and Outreach Plan include the Carlsbad and regional community as a whole. We will engage key stakeholders to identify mobility issues, concerns and solutions that will allow the City to base decisions upon authentic community input and to demonstrate responsiveness to future needs.

##### Categories of Stakeholders

**Partner Agencies:** Regional agencies, such as SANDAG, 511, NCTD and other transportation boards, will serve as important partners with committed staff that can help amplify our messaging.

**Stakeholders:** A stakeholders list and database will be created to regularly communicate with interested and affected groups and individuals.

Additional stakeholders are identified in the categories below and will be further expanded to include any additional influencers/members of the community that can reinforce the Sustainable Mobility Program's messages:

1. General Public
2. Planning Groups
3. Professional and Community Associations
4. Businesses and Corporations (small and large and business groups/organizations)
5. Business Parks
6. Education and School Districts (elementary to college, teachers, students, parents, scouts, other groups)
7. Environmental Groups/Organizations
8. Transportation Groups/Organizations
9. Medical and Public Health Groups and Professionals



*July 10, 2018*

10. Recreation Groups/Organizations
11. Housing Groups/Organizations
12. Internal (managers, staff, consultants, etc.)
13. Local Government (staff, city councils)
14. Media (local, state, national, international)
15. Regional Elected Officials (and staff)
16. Regional Transportation Boards
17. Civic Groups and Clubs
18. Tourists



July 10, 2018

## V. OUTREACH TACTICS AND ACTIVITIES

The proposed outreach strategies in this plan are designed to use cost effective methods to reach program stakeholders to increase project understanding and awareness, educate, engage, build trust and support and provide opportunities for public involvement during the environmental study process. See the Informational Tools and Toolkit section that follows for list of available resources that compliment these tactics.

### TACTICS:

#### 1. Research:

We will review information gathered from a survey conducted by Moore Associates targeting the business community; and work with Action Research to determine effective communication tools to engage a broad audience in this effort. The Action Research team will conduct a series of focus groups to determine specific messages and methods that will be most effective at encouraging public input on the SMP. The planned focus groups will be conducted in South and North Carlsbad recruiting participants by intercept method at a variety of public venues (e.g., beaches, libraries, parks, and restaurant areas).

#### 2. Stakeholder Working Groups:

We will identify contacts and secure participation for one Stakeholder Working Group (SWG). The SWG may include various local and regional representatives, such as representatives from the Carlsbad Unified School District, NCTD, San Diego County Health and Human Services, mobility advocates, Carlsbad Village Association, homeowner's associations, emergency responders, and key employers' human resource representatives, among others. In addition, it is anticipated that multiple City departments beyond planning and transportation will have a role on the SWG, including economic development, recreation, and communication staff. We will update the contact database, conduct outreach, prepare material explaining committee scope/participation purpose and schedule meetings.

Real-time, graphic recording of discussion points and outcomes will be documented on large "wallgraphics" during the community outreach meetings, along with a concise, written summary report and photo-reduction of the wallgraphics after each SWG meeting. The City will conduct all notification and Working Group outreach, as well as coordinate meeting venues.



*July 10, 2018*

To maintain interest and participation in the planning effort, the SWG meetings will be varied in terms of location, subject matter, and format. This may include site visits/walking meetings to and around proposed project locations or school sites to observe pickup and drop-off behaviors and issues, meetings to tour local businesses' efforts to implement TDM measures, or any number of potential alternative meeting types.

Meeting notices will be developed to promote the working groups and workshops, as well as any other program elements if/as needed. Multiple engagement methods will be used to disseminate the meeting notices including mass email, social media, inclusion in City newsletters, posted online and shared with community groups, regional elected officials and other interested stakeholders to distribute to their contacts.

### **3. Public Workshops:**

Community meetings, in the form of Public Workshops (with clear agenda topics and presentations that are on-message) will help to increase engagement and public input to inform the final plan and recommendations. Two Public Workshops are anticipated. The purpose of the Public Workshops will be to inform the community about the project purpose and latest developments, and to collect input on community priorities for the City's future mobility programs and projects in the near and long terms.

Notices will be prepared for each workshop for distribution by the City and partners in hardcopy and electronic formats. Technical information will be shared in presentation and handout formats with messages that are easy for the public to understand. Facilitation and community input tools and handouts will be developed, and Spanish translation professionals and equipment can be provided to support these group presentations and discussions.

The Public Workshop format may include one or more of the following formats: presentation from the project team, large group facilitation, small group facilitation, mapping exercises, and/or priority-setting exercises. A digital kiosk will be available for utilizing input tools on the project website, if appropriate. A simple facilitation guide and training/guidance for other team members will be provided one hour prior to the start of each workshop.

Summary Document - The Chen Ryan Team will summarize the input collected via flipchart pages, wallgraphics, comment cards and other methods in a concise yet thorough summary report for submittal to the City.



*July 10, 2018*

Follow-up with key stakeholders will be important, as well as resources to respond to community concerns and report back to the program team with the concerns/outcomes.

Meetings will be held at City facilities with location logistics/refreshments managed by the City. Additional venue like the local outlet mall can be considered. Chen Ryan/MIG will take the lead on logistics, staffing and facilitating the Community Workshops and NV5 will take the lead on stakeholder identification given their experience with the Carlsbad business community. NV5's stakeholder outreach will also allow for one-on-one meetings and discussions with key community representatives, particularly upon presentation of program recommendations to address key concerns.

**Speaker Training:** It is important that public-facing staff receive speaker's training if they are to be included in the community meetings as they will need to be well-versed in the messages that they will convey and as they assist the public in person or by phone in the months to come as the SMP information is presented. Staff should be upbeat in reassuring some members of the public who have strong negative reactions to the SMP.

#### **4. School-Based Outreach:**

Carlsbad students and their families can benefit from better, safer connections between their homes and their schools. The project team will evaluate the walking and bicycling environments around public schools in Carlsbad to identify ways to make the journey to and from school safer, more convenient, and less congested.

Following a technical evaluation period, the team will meet with school representatives to review potential improvements and explore potential partnerships for encouraging students to walk and bike to school, educating the school community on alternatives to driving to campus, and how to work collaboratively to alleviate school congestion.

#### **5. Employer Outreach:**

Carlsbad employers can benefit from neighborhoods designed to allow a variety of transportation modes, and they have a significant role to play in facilitating access to their sites by alternative modes, through both incentive programs and participation in planning processes. The forthcoming TDM ordinance that Carlsbad is planning to implement demonstrates the City's commitment and willingness to support collaboration from all stakeholders to reach its mobility goals.





*July 10, 2018*

We anticipate up to two (2) employer-specific outreach events to engage with businesses on the City's plans to draft a SMP to reduce emissions and encourage multi-modality while ensuring business retention and attraction. The outreach will take place in various locations to contact a maximum number of businesses, employees, and general audiences.

The following Employer Outreach events will be considered:

- Brown bag meetings at large-scale places of work such as Legoland and Callaway Golf.
- Happy Hour Meet and Greet hosted in collaboration with partners such as Carlsbad Chamber of Commerce and Carlsbad Village Association.
- Pop-up events in lobbies or entrances to connect with employees.
- Input collected through these outreach events will be documented in a short report to support subsequent tasks.

#### **6. Meeting Collateral:**

We will develop graphics for usage on informational boards, online and in print materials. We will develop PowerPoint slides, handouts, invitations, sign in sheets and other materials as needed in formats suitable for either print or electronic distribution.

High-level briefing material will also be developed for elected officials and others in leadership positions to include talking points and look-ahead summaries. This information can be included in weekly emails to the City Council or as a more formal memo or briefing document from the City Manager's Office to provide clear messaging information.

#### **7. Online Engagement:**

We will develop content to support online engagement efforts, such as surveys or meetings/workshops promotion via copy and images prepared specifically for social media, website and emails with text, photos, illustrations and/or mobile phone video clips. We will review of social media public input and sentiment, and draft specific responses for City staff to consider. Analysis will be provided for digital ads to be purchased using geofencing and other targeted tools.



July 10, 2018

**Website:** Augment the existing City website with updated information about the program or create a new program website/landing page that can then point to existing assets and materials on the City website. Among the items presented online will be photos, videos, email sign up, event information, student/educator information and tracks analytics, including visits, unique visitors, page views and the average duration on the site. The analytic information will be used to inform efficacy of the website.

The workflow for producing assessments is significantly improved using this innovative technology, and impresses upon participants an elevated level of technical competence and sophistication. These issue points can then be exported into GIS to speed existing conditions reporting and basemapping.

**GIS:** ArcGIS Online Storymaps can also be considered for online usage to show program recommendations in one place.

**MetroQuest:** This digital tool will be utilized for outreach in conjunction with the City Communications department.

**Social Media:** Social media presence for the program will be enhanced on Carlsbad social media outlets (Facebook, Twitter, Instagram, etc.) with active engagement throughout the process. Assets including snackable video vignettes will be shared, as will community meetings and engagement opportunities. In addition, alignment with prominent community influencers can be pursued for live postings related to the program. Social media analytics will be monitored to track perceptions and evaluate social media efforts to improve the communication program.

**Videos:** "Snackable" video vignettes can be designed specifically for use on social media to provide short form snippets of program elements tied to community profiles so key stakeholder groups to clearly envision their role and usage of the proposed solutions.

## 8. Educational Outreach

As we work to disseminate and reinforce the messages of positive impact the SMP will have on the community, it will be important to expand outreach to schools and educational institutions in the area to maintain support and build champions for the project among educators and students.



*July 10, 2018*

## **9. Media Relations**

Press releases will be drafted and distributed to provide accurate and timely information about important issues and at program milestones to keep media representatives current and involved on project issues that impact program stakeholders. Media alerts and opinion-editorials may also be developed to help educate stakeholders about the Sustainable Mobility Program.

## **10. Interested Partners**

Program partners, other cities and/or municipalities, local, regional, state and federal agencies that are committed to the Carlsbad Sustainable Mobility Program will be provided access to a communication tool kit to assist in outreach on this program for their unique audience. The SMP communication team will provide strategic counsel so that key messages are consistent and united, and assistance with two-way information flow, material development, audience engagement, answering questions and encouragement to share program messages.

## **11. Ambassador Program**

Community members and project champions can be identified to build ambassadors for the SMP. These volunteers would need to participate in an official educational training so they are able to accurately talk about the program, deliver key message points and articulate the program purpose and need to neighbors, community groups and the public at large, as well as possibly the media and elected officials.

## **12. Industry Outreach**

We can identify opportunities to highlight the program in the sustainability, transportation and environmental trade industries through conferences, trade media, speaking opportunities, sponsorships and tours and expand this initiative to include international as well as domestic industry opportunities to highlight and amplify our efforts. This effort enables us to help further SMP best practices for the overall relevant industries and to communicate the work that program partners are doing as leaders in emerging mobility efforts and technologies.



*July 10, 2018*

## **VI. INFORMATIONAL TOOLS AND TOOLKIT**

An online toolkit can be prepared to assist program partners and other interested parties to communicate with their own stakeholders/targeted audiences.

Recommended outreach items in the toolkit can include:

- Program fact sheet and FAQs.
- Program schedule.
- Educational materials as developed.
- Video links.
- Images such as a photo kit/bank and graphics catalogue.
- Style Guide (writing style, branding guidance and logo use).
- Social media posts to drive stakeholders to the program website to learn about the program, sign up for emails and attend community meetings
- Presentations and presentation comment card.
- Press releases and media coverage if/as posted. The press releases will provide program information to local newspapers, media outlets and newsletters as appropriate.
- Media kit and if/as available sample media quotes.
- An article in a City or community newsletter/platform providing a program introduction and encourage engagement and attendance at community meetings.



*July 10, 2018*

## **VII. SCHEDULE**

Please refer to the attached Program Schedule. Specific details related to public outreach and engagement activities include:

1. Key dates
2. Key deadlines
3. Meeting dates as they are established

It will be important to take into account any other changes happening at the City and affected stakeholders and internal departments during the SMP outreach timeframe.

Annual holidays and City elections (two Districts and the Mayor's race) will be considered as an important activity during the time that messaging on this program will be taking place in the community.