

**Carlsbad Fire Department
Fire Prevention Bureau**

**Guideline for
Underground Piping for Private
Hydrants & Sprinkler Supply Line**



Approved and Authorized By:

Randall Metz, Fire Marshal

Issued: February 15, 2021

Guideline for Underground Piping for Private Hydrants & Sprinkler Supply Line

PURPOSE

The purpose of this guideline is to provide the basic information necessary to meet minimum requirements for the design and installation of private hydrant and/or sprinkler supply underground piping in accordance with the provisions of the 2019 California Fire Code (CFC), the 2019 California Building Code (CBC), and the 2016 editions of NFPA 24, NFPA 13, NFPA 13R, as adopted by the State of California, and locally adopted ordinances enforced by the city of Carlsbad, Office of the Fire Marshal (CFD).

SCOPE

This guideline provides specific requirements for the installation all private underground piping for hydrants and/or sprinkler supply lines within the City of Carlsbad.

SUMBITTAL REQUIREMENTS

1. General Requirements

- A. All new plan submittals and revisions will consist of 3 hard copies.
- B. Plans shall be legible, scaled to nationally recognized standards, and printed as a blue- or blackline drawing. The City of Carlsbad does not accept either pen and ink plans or pen & ink changes to blue-line plans.
- C. Plans for all private underground piping for private hydrants and/or sprinkler supply line(s) shall be submitted to City of Carlsbad for review and approval prior to installation.
- D. A current (within six months), completed Water Availability form shall accompany plans.
- E. The contractor's name, telephone number, address, and California State contractor's license number and classification. Contractors must possess a valid A, C16, or C34 license or be registered as a Professional Engineer (PE). Note: If the piping plan is designed by a PE, the plan shall contain the name, license number, and classification of the installing contractor, along with the PE wet stamp. If this information is not available at the time the plans are submitted, proof of compliance with this requirement must be provided to the CFD at time of inspection.

- F. Applicable codes and standards used for the system design (e.g., 2019 CFC, 2019 CBC, 2016 NFPA 24, etc.).
- G. Project location, including the full legal address of the facility, and building number(s) if applicable; tract or parcel number.
- H. Installation, inspection, and testing shall conform to 2016 editions of NFPA 13 and NFPA 24. CFD jurisdiction begins at the downstream side of the last valve on the detector check assembly. Verify design and installation requirements for the portion of the system preceding this point with the local water district.
- I. Approval of this plan shall not be interpreted as approval of any information or project conditions other than those items and requirements identified in CFD Guideline, and applicable sections of the 2016 editions of NFPA 13 and NFPA 24. This project may be subject to additional requirements not stated herein upon examination of actual site and project conditions or disclosure of additional information.
- J. Any future modification to the approved private underground piping system is subject to review, inspection, and approval by the CFD.
- K. The attached “NOTES FOR UNDERGROUND PIPING FOR PRIVATE HYDRANTS AND SPRINKLERS” shall be placed, verbatim, on all underground plans. The attached “NOTES FOR THRUST BLOCK RESTRAINTS” shall be placed, verbatim, on all underground plans that use thrust blocks as the restraining method.

2. Additional Required Information

- A. Location of public mains and all public hydrants within 300 feet of the site.
- B. Location of all valves. Specify the type for each (e.g., post indicator valve (PIV), key gate valve, system control valve, double detector check (DDC) assembly, outside stem and yoke (OS&Y), etc.).
- C. PIVs or other approved indicating valves, shall be located a minimum of 40 feet from the building served. Where it is impractical to locate control valve(s) 40 feet from the building served, they may be located closer by one of the following methods:
 - 1) Approved wall mount indicating valves: Located on exterior walls without openings within 15 feet of the valve/s.
 - 2) Valve room: When the valve is placed in a room separated from the building by a one-hour fire barrier and the room is accessible from outside.
 - 3) Exterior risers: The valve may be placed in locations adjacent to exterior walls without openings within 15 feet of the valve.
 - 4) An approved manner acceptable by CFD.
- D. Pipe size, class, and type; specify lined or unlined if applicable.

- E. Indicate that ferrous pipe and fittings (excluding stainless steel 316) shall be encased in loose-fitting polyethylene tubing (pipe shall not be wrapped in polyethylene sheets) and that ferrous joints, pipe, and fittings shall be coated with asphaltic sealant or equivalent to inhibit corrosion. Exposed edges, cuts, and tears shall be tightly taped to inhibit water infiltration. Where joints are present in tubing, a minimum one-foot overlap shall be provided. Tubing shall extend three feet beyond transition between areas where ferrous pipe or fittings are used and where non-ferrous pipe begins.
- F. All bolts used for underground connections, including T bolts, shall be 316 stainless steel. Asphaltic sealants (and other opaque sealants) shall not be used to coat bolts (this is to ensure bolts can still be verified as 316 stainless steel during inspection).
- G. Thrust block locations or specify the means of restraint as approved by 2016 NFPA 24.
- H. Location of the fire department connection (FDC). FDCs shall be on the address side of the building and located immediately adjacent to the approved fire department access road. The FDC shall be in a position allowing hose lines to be readily and conveniently attached and does not cross fire department access roads. The FDC shall contain a minimum of two 2½" inlets. When the sprinkler demand is 500 gpm or greater (including the interior hose stream demand) or a standpipe system is included, four 2½" inlets shall be provided. The FDC shall be a listed assembly, i.e. Potter-Roemer FDC Models 5761-5764, 5775, 5776, 5780, 5781, 5785, 5786, Guardian FDC Models 6224, 6226, 6242, 6244, or similar listed devices. Note: These are just examples of the models that would be accepted by CFD. CFD does not endorse any specific manufacturer.
- I. FDC's shall be no more than 100 feet from a public hydrant. The FDC may be located within 100 feet of a private hydrant if the FDC is connected to the fire sprinkler system by a dedicated pipe that connects on the system side (i.e., downstream) of the sprinkler system check valve.
- J. FDCs, PIVs, and backflow assemblies shall be readily visible and accessible from the fire lane. Vegetation may be used to screen backflow assemblies on the side that does not face the fire department access roadway.
- K. FDCs, PIVs, and DDCs, shall have durable, legible signs clearly indicating the address of the facility they serve or, where appropriate, their function (e.g., "Sectional Valve 1 of 2"). Signs shall be securely attached to the device.
- L. Large private fire service mains shall have post indicating type sectional control valves at appropriate points in order to permit isolation of the system in the event of a break or during repair or extension. Note: A large system is considered one with more than four connections including fire hydrants.

M. Provide a fire riser detail. When a pipe runs under footings or foundations of the building, a single corrosion resistant stainless steel pipe unit assembly is required. The pipe shall terminate a maximum of 18 inches from the exterior wall and six inches above the finished floor. A minimum of 2 inches clearance (annular space) shall be provided where the pipe passes through the floor or wall.

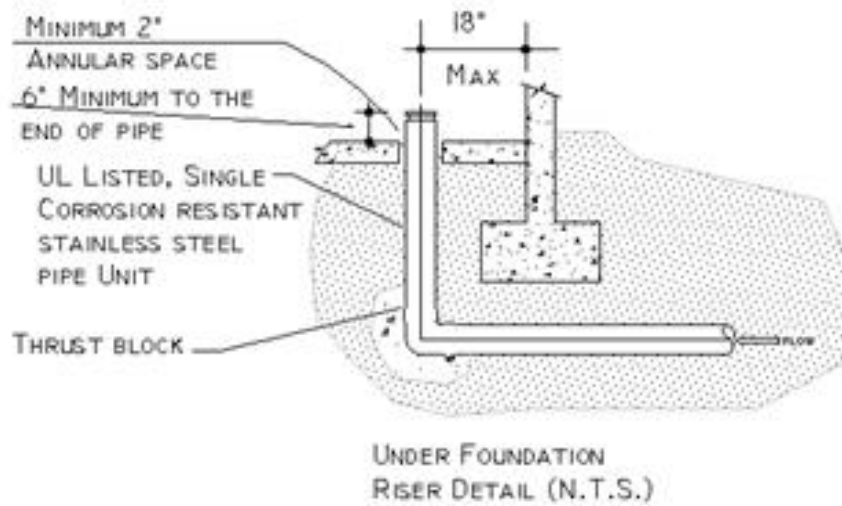

N. Provide a typical trench detail/section showing the depth of bury and thickness of sand bedding above and below the pipe.

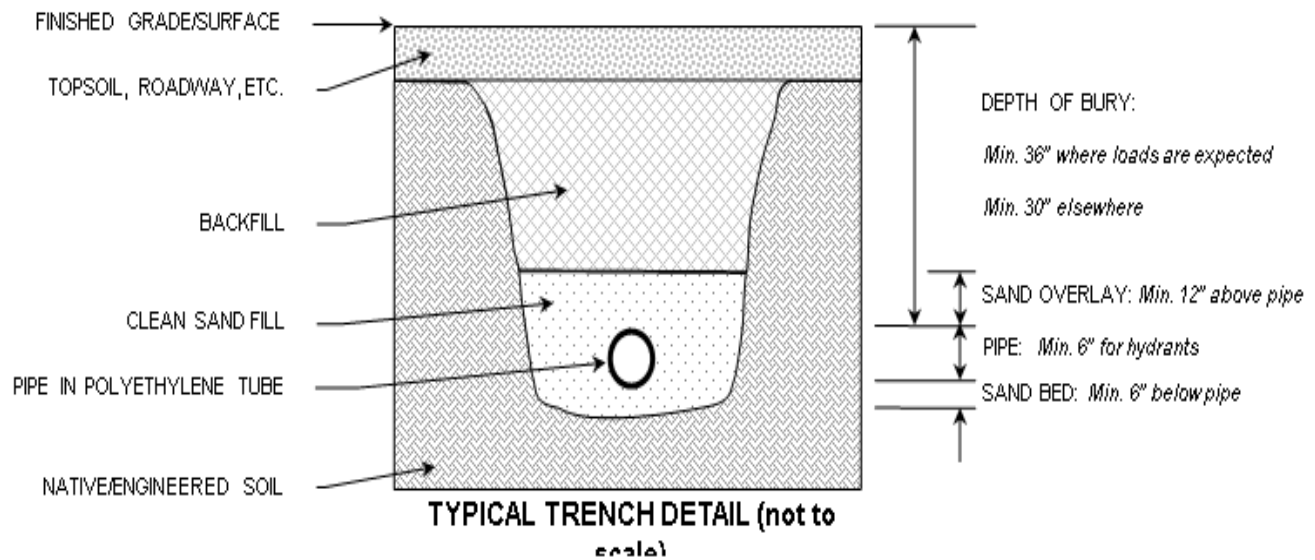

3. Underground Service for NFPA 13R Systems

Underground service shall comply with one of the following designs based upon the parameters described:

- A. The system design shall comply with NFPA 13 and NFPA 24 (see Sections 1 through 3 above) when:
 1. Serving more than one R-1, R-2, or R-4 occupancy, or
 2. The FDC is located between the city supply and sprinkler riser check valve.
- B. The system design shall comply with NFPA 13R and the California Plumbing Code (CPC) when:
 1. Serving a single R-1, R-2, or R-4 occupancy, and
 2. The FDC is located downstream of (i.e., after) the sprinkler system riser check valve. The underground system may be interconnected with the building's domestic water supply line or may be a dedicated fire line. The FDC shall also comply with relevant requirements listed in this guideline including, but not limited to, identification, painting, accessibility, and orientation.

4. City of Carlsbad Notes

All the notes listed below shall be placed, verbatim, on the plan under the heading

“CITY OF CARLSBAD NOTES”

INSPECTION REQUIREMENTS

- A. A minimum of three CFD inspections are required for underground piping serving sprinkler systems and/or private hydrants: 1) Pre-pour inspection; 2) Hydrostatic testing; 3) Flush inspection. Please schedule all inspections at least 48 hours in advance. Call CFD Inspection Scheduling at (760) 602-4660.
- B. **Pre-pour inspection:** Thrust block excavation shall be completed but thrust blocks shall not be poured. All pipe shall be in place and exposed for visual inspection. Pipe shall be laid on a minimum six-inch bed of clean sand. Trenches shall be of a sufficient depth to allow the required cover above pipe. Ferrous pipe and fittings shall be encased in polyethylene tubing (not wrapped) and tightly taped to inhibit water infiltration. Ferrous joints (with the exception of stainless steel 316) shall be coated with asphaltic sealant or other corrosion retarding material. See items 11 – 19, 21 and 22 below for detailed requirements.
- C. **Hydro Testing:** Thrust blocks shall be in place. Pipe shall be center-loaded with clean sand to prevent uplift, but all joints shall remain exposed. The system shall be hydrostatically tested at 200 psi (or 50 psi over maximum static pressure, whichever is greater) for a duration of at least two hours prior to the arrival of the CFD inspector. See item 16 for detailed requirements.
- D. **Flush inspection:** All portions of the underground system shall be flushed to remove debris prior to connection to overhead piping. Flow shall be through a minimum of a four-inch hose or pipe, unless otherwise approved by the CFD inspector prior to scheduling the flush. Hose or pipe shall be restrained to prevent injury and damage. The local public works department, water district, and/or other applicable agency shall be notified of the scheduled flush by the contractor. The CFD flush and hydro inspections may be scheduled concurrently. See items 11, 18, and 20 – 23 below for detailed requirements. Discharged water shall be collected or diverted in accordance with applicable SWPPP/NPDES provisions. Fire sprinkler systems without corrosion inhibitors, fire suppressants, or antifreeze, must meet the following requirements.
 - 1) discharge to the sanitary sewer system, if feasible.
 - 2) conduct flush on days without a prediction for rain.
 - 3) direct flows to a paved area for evaporation/wet vacuuming and sweeping.
 - 4) infiltrate flows in suitable landscape area without causing erosion or runoff

- 5) clean trash and debris from the flow path to the storm drain inlet and mechanically filter remaining flow with an appropriate filter fabric or other equivalent media prior to discharge to the storm drain system.
 - a) Upon flush inspection or prior to final sprinkler or site inspection, all detector check assemblies, control valves, and fire department connections (FDC) shall be clearly labeled with the address(es) served by the device. Address signs shall be securely attached to the device and be of a durable, fade-resistant material which is visible and legible from the fire lane. FDC and four-inch hydrant outlets shall be unobstructed and oriented toward the fire lane. Valves shall be locked in the open position with breakaway locks. All PIV valves and private hydrants shall be painted OSHA safety red. The closest upstream indicating valve to the riser shall be painted OSHA safety red. Hydrant and FDC caps shall be in place. See items 6 – 9, 18, and 20 – 23 for detailed requirements.
 - b) Operating Test: Each hydrant shall be fully opened and closed under system water pressure. All control valves shall be fully closed and opened under system water pressure to ensure proper operation.

GENERAL REQUIREMENTS

- A. Vegetation shall be selected and maintained in such a manner as to allow immediate location of, and unobstructed access to; all hydrants, control valves, fire department connections, and other devices or areas used for firefighting purposes.

PIPE AND TRENCH REQUIREMENTS

- A. A 6-inch bed of clean fill sand shall be provided below the pipe and 12-inches above the pipe (total of 18 inches plus outer diameter of the pipe).
- B. Pipe shall be buried at least 36" where subject to loading (e.g., driveways, parking lots) and at least 30" elsewhere.
- C. All pipe shall be approved for use in fire service systems. Class 150 will be used at a minimum, and class 200 pipe shall be used where the water pressure exceeds 150 psi. The use of galvanized pipe is prohibited when a portion of the system is buried.
- D. All ferrous pipe and fittings shall be protected with a loose 8-mil polyethylene tube. Wrapping the pipe in polyethylene sheeting is not acceptable. The ends of the tube and any splices made for tees or other piping components shall be tightly sealed with two-inch tape that is approved for underground use.
- E. All bolts used for underground connections, including T bolts, shall be 316 stainless steel. Asphaltic sealants (and other opaque sealants) shall not be used to coat bolts

(this is to ensure bolts can still be verified as 316 stainless steel during inspection). All ferrous fittings (with the exception of 316 stainless steel) shall be cleaned and thoroughly coated with asphalt or other corrosion retarding material after assembly and prior to the installation of polyethylene tube

- F. Thrust blocks, or another approved method of thrust restraint, shall be provided wherever pipe changes direction.
- G. A minimum two-inch clearance shall be provided where the pipe passes through slabs or walls. Underground system shall terminate at the riser flange and placed a maximum of 18 inches from an exterior wall and 6 inches above the slab.
- H. The FDC shall contain a minimum of two 2 ½" inlets. When the system design demand, including the interior hose stream demand or a standpipe, is a minimum 500 gpm, four 2 ½" inlets shall be provided. FDCs shall be painted OSHA safety red.
- I. Pipe running under a building or building foundation shall be stainless steel and shall not contain mechanical joints.

Hydrant Requirements

- A. Private fire hydrants shall be listed with a minimum of one 2 ½" and one 4" outlet. The 4" outlet shall face the fire department access road. All outlets shall be provided with National Standard Threads (NST). Private hydrants shall be painted OSHA safety red.
- B. Fire hydrant supply piping shall be a minimum of six inches in diameter. The lowest valve operating nut shall be a minimum of eighteen inches above grade and the hydrant flange shall be a minimum of two inches above grade.
- C. A keyed gate valve shall be provided for each hydrant in an accessible location. Keyed gate valves shall be located within six to ten feet of the hydrant in an area that is unobstructed and clearly visible. Valves shall not be located in parking stalls.
- D. All fire hydrants shall have a "Blue Reflective Pavement Marker" indicating their location per the CFD standard detailed in Access Guideline. Private hydrants and markers are to be maintained in good condition by the property owner.