

# ATTACHED RESIDENTIAL DECKS B-4

A Building Permit is required for residential decks and must comply with the Zoning Ordinance, including building setbacks, structure separation requirements and lot coverage. This hand out describes what plans are necessary to secure a deck permit. To assist you, there is a sample of a plot plan, span tables for: joists and beams, cantilever length for deck joists, deck post height limits and there is a footing schedule for foundation requirements. If the deck is free-standing, outside the table limits in this handout, closer than 5' to the property line, or built within a very high fire hazard severity zone, please provide a foundation plan, framing details, and other details and elevations designed by a licensed, practicing Structural Engineer to show the extent of the proposed work. A complete structural analysis may be required for decks outside the scope of this handout. If you use this handout for the design - highlight each proposed size or dimension on each table A-E.

**1. Two Identical Site Plans showing:**

- a. Property lines with dimensions.
- b. Proposed deck and stairway (if applicable).
- c. Distances from posts to property lines.
- d. All existing structures on the property.
- e. Indicate the dimensions of the deck and the total deck square footage.
- f. Any easements on the property.
- g. Percentage of lot coverage.

**2. A Building Permit Application with the following:**

- a. Name of the property owner.
- b. Home Phone Number
- c. Site address, assessor's parcel number, lot number, subdivision name or number.
- d. Contractor's name, State License Number and City Business License Number; or an Owner-Builder Declaration Form (Available at the Building Division Counter).
- e. Signature of Applicant

If you are applying for a building permit in a subdivision with a homeowner's association, you should secure architectural review prior to proceeding with the project. The City does not enforce or specifically review provisions of homeowners' association CC&R's. HOA requirements may be different than City requirements.

If you are applying for a building permit in the Coastal Zone, you may need a Coastal Development Permit or an exemption. Contact the Planning Division for details. A Coastal Zone map is part of this handout. If you are applying for a building permit in a subdivision with a homeowner's association, you should secure architectural review prior to proceeding with the project. The City does not enforce or specifically review provisions of homeowners' association CC&R's. HOA requirements may be different than City requirements. If your home is part of a Planned Unit Development or a condominium, please see text of this handout.

**FIGURE 1 - SAMPLE DECK SITE PLAN**

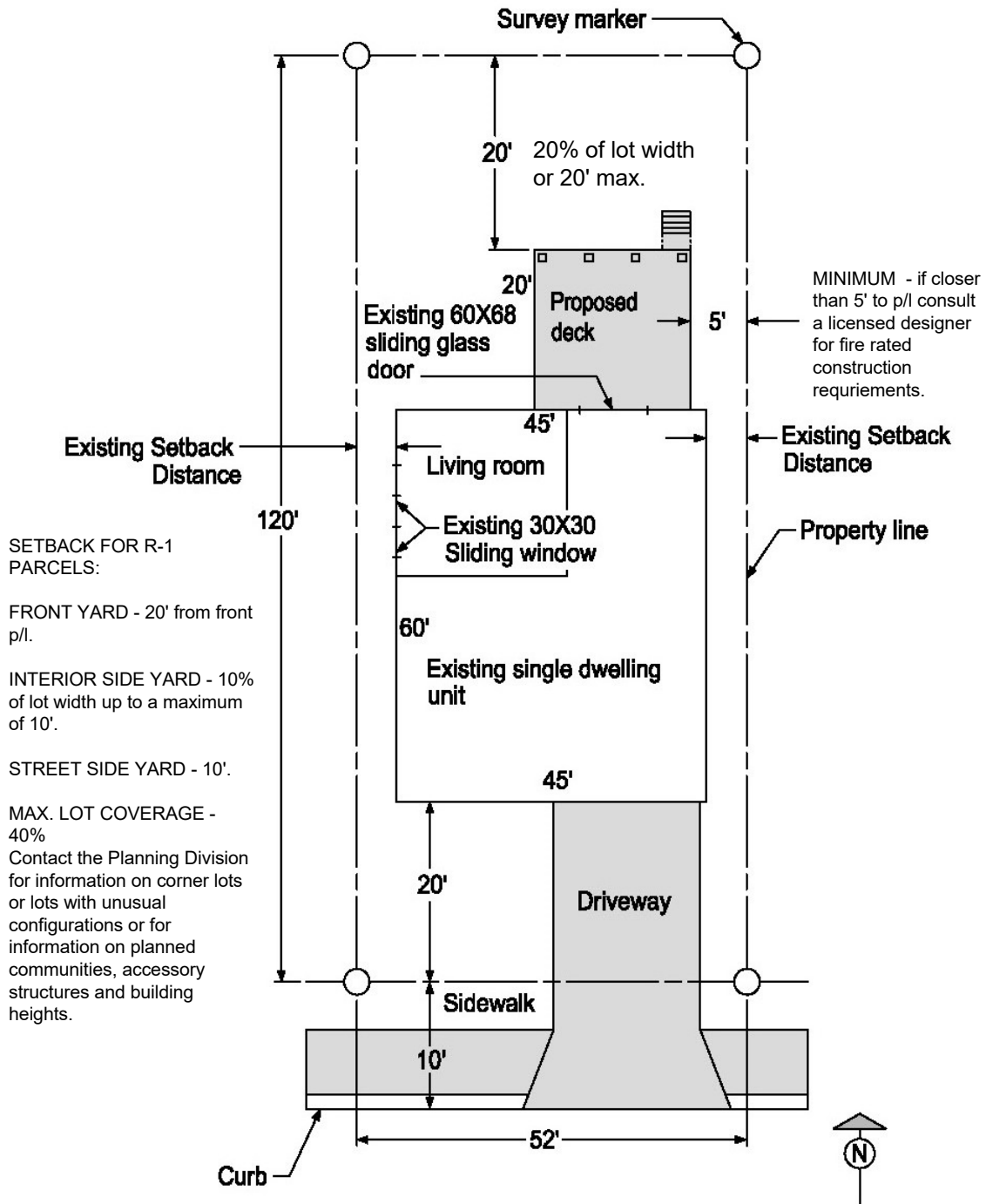

\*Shown as an example of minimum plan submittal details required on a site plan.

**TABLE A - ALLOWABLE SPAN FOR DECK JOISTS (ft. - in.)<sup>1,2,3</sup>**

Species	Size	Spacing of Joists (inches)		
		12	16	24
<b>Douglas fir - larch #2 or Redwood #1</b>	<b>2 x 6</b>	<b>6-9</b>	<b>6-2</b>	<b>5-1</b>
	<b>2 x 8</b>	<b>8-10</b>	<b>7-10</b>	<b>6-6</b>
	<b>2 x 10</b>	<b>11-2</b>	<b>9-7</b>	<b>7-10</b>
	<b>2 x 12</b>	<b>12-9</b>	<b>11-2</b>	<b>9-1</b>

1. Live load = 60 psf, Dead load = 10 psf, L/Δ = 360.
2. If Joists within 8" inches of grade, use Pressure - Treated Douglas Fir - Larch or foundation - Grade Redwood.
3. Include incising factor (Ci=0.8)

**TABLE B - CANTILEVER LENGTH FOR DECK JOISTS (ft. - in.)<sup>1,2,5</sup>**

Size	Spacing (in.) <sup>3,4</sup>		
	12	16	24
<b>2x6</b>	<b>1-0</b>	<b>0-10</b>	<b>0-9</b>
<b>2x8</b>	<b>1-7</b>	<b>1-6</b>	<b>1-5</b>
<b>2x10</b>	<b>2-5</b>	<b>2-2</b>	<b>2-0</b>
<b>2x12</b>	<b>3-2</b>	<b>2-10</b>	<b>2-3</b>

1. Live load = 60 psf, Dead load = 10 psf, L/Δ = 240
2. Beam cantilevers are limited to the adjacent beam's span divided by 4.
3. Joist spacing for diagonal decking shall not exceed 16 inches.
4. Cantilever span includes 220 lbs. point load applied to end.
5. Solid blocking shall be provided between joists at the support.

**TABLE C - DECK BEAMS**

Beam span lengths (ft.- in.)<sup>1, 2, 3, 4, 6, 7</sup>

Species	Size <sup>(5)</sup>	Joist span less than or equal to: <sup>(8)</sup>							
		6 ft.	8 ft.	10 ft.	12 ft.	14 ft.	16 ft.	18 ft.	
<b>Douglas Fir – Larch #2</b>	<b>3 x 6 or 2 – 2 x 6</b>	<b>3-9</b>	<b>3-3</b>	<b>3-0</b>	<b>-</b>	<b>-</b>	<b>-</b>	<b>-</b>	
	<b>3 x 8 or 2 - 2 x 8</b>	<b>4-9</b>	<b>4-3</b>	<b>3-9</b>	<b>3-5</b>	<b>3-2</b>	<b>-</b>	<b>-</b>	
	<b>3 x 10 or 2 - 2 x 10</b>	<b>5-10</b>	<b>5-2</b>	<b>4-7</b>	<b>4-3</b>	<b>3-10</b>	<b>3-7</b>	<b>3-4</b>	
	<b>3 x 12 or 2 - 2 x 12</b>	<b>6-10</b>	<b>5-11</b>	<b>5-3</b>	<b>4-10</b>	<b>4-6</b>	<b>4-3</b>	<b>4-0</b>	
	<b>4 x 6</b>	<b>4-6</b>	<b>3-10</b>	<b>3-5</b>	<b>3-3</b>	<b>-</b>	<b>-</b>	<b>-</b>	
	<b>4 x 8</b>	<b>5-11</b>	<b>5-2</b>	<b>4-7</b>	<b>4-3</b>	<b>3-10</b>	<b>3-9</b>	<b>3-5</b>	
	<b>Redwood #1</b>	<b>4 x 10</b>	<b>7-0</b>	<b>6-2</b>	<b>5-4</b>	<b>4-10</b>	<b>4-6</b>	<b>4-3</b>	<b>3-10</b>
		<b>4 x 12</b>	<b>8-2</b>	<b>7-1</b>	<b>6-4</b>	<b>5-8</b>	<b>5-3</b>	<b>4-10</b>	<b>4-7</b>
		<b>3 - 2 x 6</b>	<b>5-3</b>	<b>4-9</b>	<b>4-3</b>	<b>3-10</b>	<b>3-7</b>	<b>3-4</b>	<b>3-2</b>
		<b>3 - 2 x 8</b>	<b>6-9</b>	<b>6-0</b>	<b>5-3</b>	<b>5-0</b>	<b>4-7</b>	<b>4-3</b>	<b>4-0</b>
	<b>3 - 2 x 10</b>	<b>8-6</b>	<b>7-5</b>	<b>6-7</b>	<b>5-8</b>	<b>6-0</b>	<b>5-3</b>	<b>5-0</b>	
	<b>3 - 2 x 12</b>	<b>9-10</b>	<b>8-6</b>	<b>7-8</b>	<b>7-0</b>	<b>6-5</b>	<b>6-0</b>	<b>5-8</b>	

1. Live load = 60 psf, Dead load = 10 psf, L/Δ = 360 at main span.
2. Beams supporting deck joists from one side only. See footnote (8) below for beams supporting cantilevered joists.
3. Beam depth shall be greater than or equal to depth of joists with a flush beam condition.
4. Beams within 8" of grade shall be Pressure-Treated Douglas Fir-Larch or Foundation – Grade Redwood.
5. Beams plies shall be fastened with two rows of 10d threaded nails or #10d nails at 16" on center along the edges.
6. Beams are permitted to cantilever not more than one-fourth of the span.
7. Include incising factor (Ci = 0.8)
8. Beams supporting cantilevered joists:  
 To select a joist span from Table, use span length equal to joist span length + 125% of cantilevered length.  
 (Example: Joist with 12 ft. span & 3 ft. cantilevered length, calculated joist span = 12' + 125% X (3') = 15.75' therefore, beam allowable span shall be based on 16' joist span).

**TABLE D - DECK POST** <sup>1,2</sup>

Post Size	Maximum Height <sup>(3)</sup>
<b>4 x 4</b>	<b>4'-10"</b> <sup>(4)</sup>
<b>4 x 6</b>	<b>7'-0"</b>
<b>6 x 6</b>	<b>10'-0"</b>
<b>8 x 8</b>	<b>14'-0"</b>

1. Deck loads: Live load = 60 psf, Dead load = 10 psf
2. Species: Douglas Fir-Larch #1, or Redwood #1
3. Measured to the underside of the beam.
4. Maximum permitted height is 5'-8" when supporting one and two-ply beams.

**TABLE E—SQUARE FOOTING AT POSTS (INCHES)** <sup>1</sup>

Footing Dimensions	Tributary Area (sq. ft.) <sup>(5)</sup>							
	20	40	60	80	100	120	140	160
Width (in.)	12	18	21	25	28	30	33	35
Depth (in.)	8	8	10	10	12	12	14	16

1. Footings shall have #4 @ 12" each way at bottom.
2. Concrete strength minimum 2,500 PSI.
3. Footing sizes are based on 1,500 PSF allowable soil bearing pressure.
4. Footings shall be placed not less than 12 inches below the undisturbed ground surface.
5. Area of deck surface supported by a post and a footing.

**TABLE F - NAILING SCHEDULE FOR DECKS** <sup>1,3</sup>

Connection	Nails or Screws (Box or Common)
<b>Joist to Girder</b>	<b>3-8d common nails</b>
<b>2 inches nominal thickness spaced decking boards approximately 1/8" apart</b> <sup>(2)</sup>	<b>2-8d threaded nails or 2 #8 screws</b>

1. Decking within 8 inches of grade shall be Pressure-Preservative treated lumber or foundation- Grade redwood.
2. Decking placement may range from an angle perpendicular to Joists to an angle of 45 degrees to the joists.
3. Each segment of decking must bear on minimum of 3 Joists.
4. All fasteners and connectors shall be hot-dipped galvanized or stainless steel.

**FIGURE 2 -STRUCTURES ON OR ADJACENT TO SLOPES/FOUNDATION CLEARANCE FROM SLOPES**

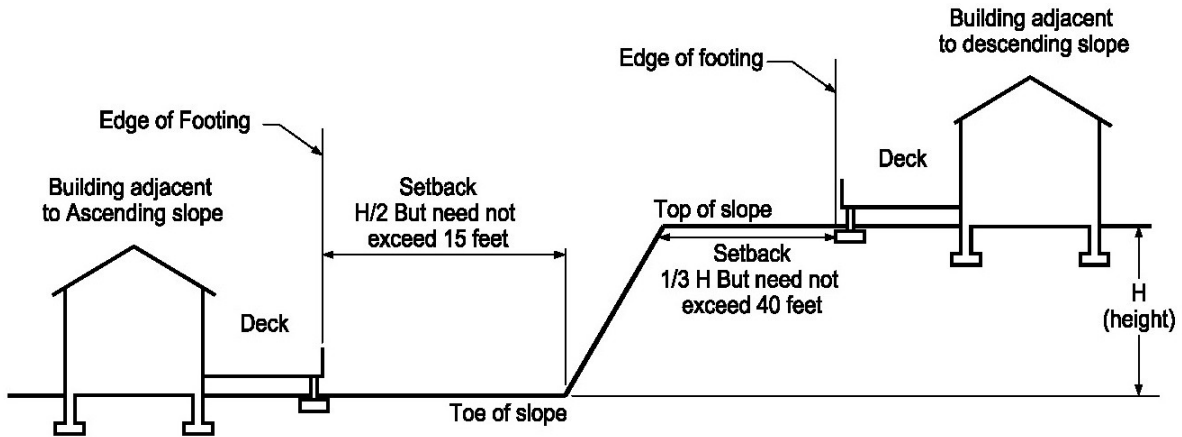

**FIGURE - TYPICAL DECK**

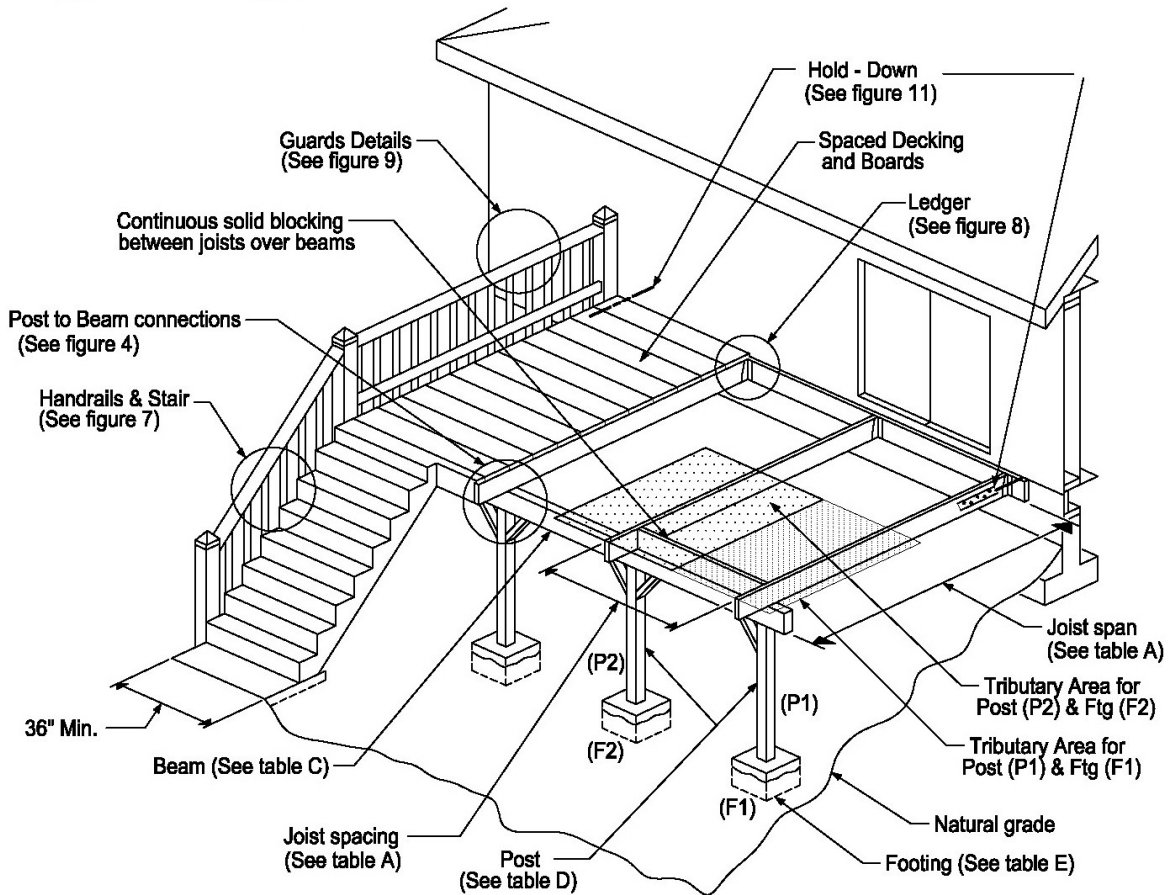

WOOD DECKS IN AREAS WITHIN VERY HIGH FIRE HAZARD SEVERITY ZONES OR CITY OF SAN DIEGO BRUSH MANAGEMENT ZONES MAY BE SUBJECT TO ADDITIONAL REQUIREMENTS

**FIGURE 4 - POST-TO-GIRDER CONNECTION**

**Case 1 / End Condition**

**Case 2 / Interior Condition**

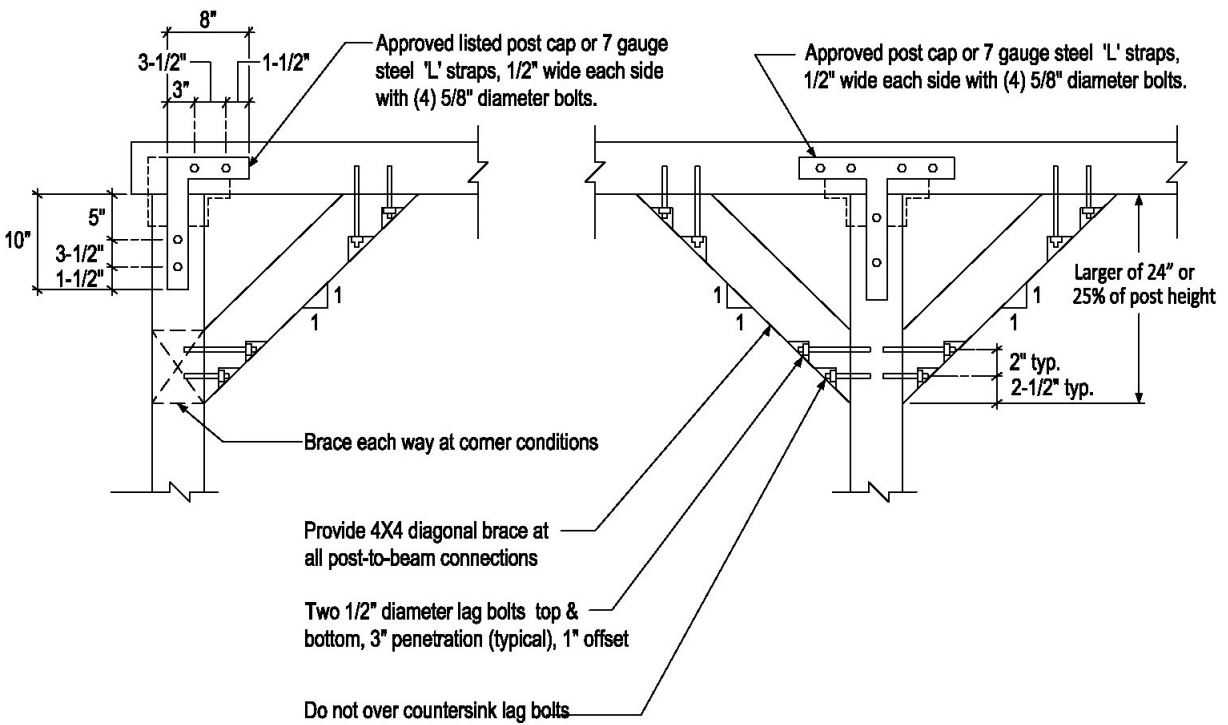

**FIGURE 5 - TYPICAL DECK ELEVATION LOOKING PARALLEL TO REAR OF DWELLING**

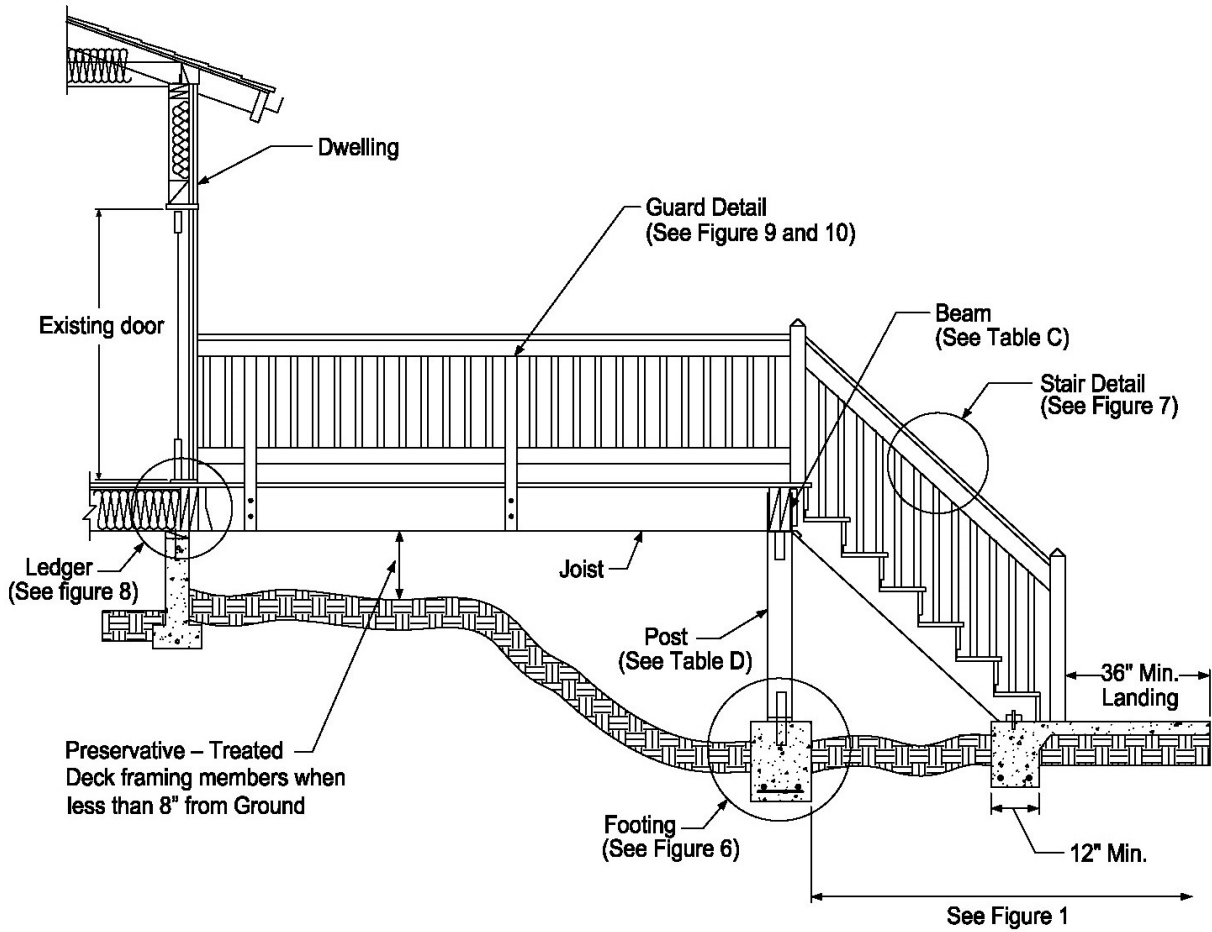

WOOD DECKS IN AREAS WITHIN VERY HIGH FIRE HAZARD SEVERITY ZONES OR CITY OF SAN DIEGO BRUSH MANAGEMENT ZONES MAY BE SUBJECT TO ADDITIONAL REQUIREMENTS



**FIGURE 6 - TYPICAL FOOTING DETAIL**

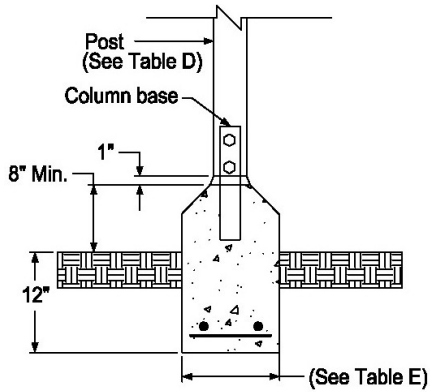

**FIGURE 7 - TYPICAL STAIR DETAIL**

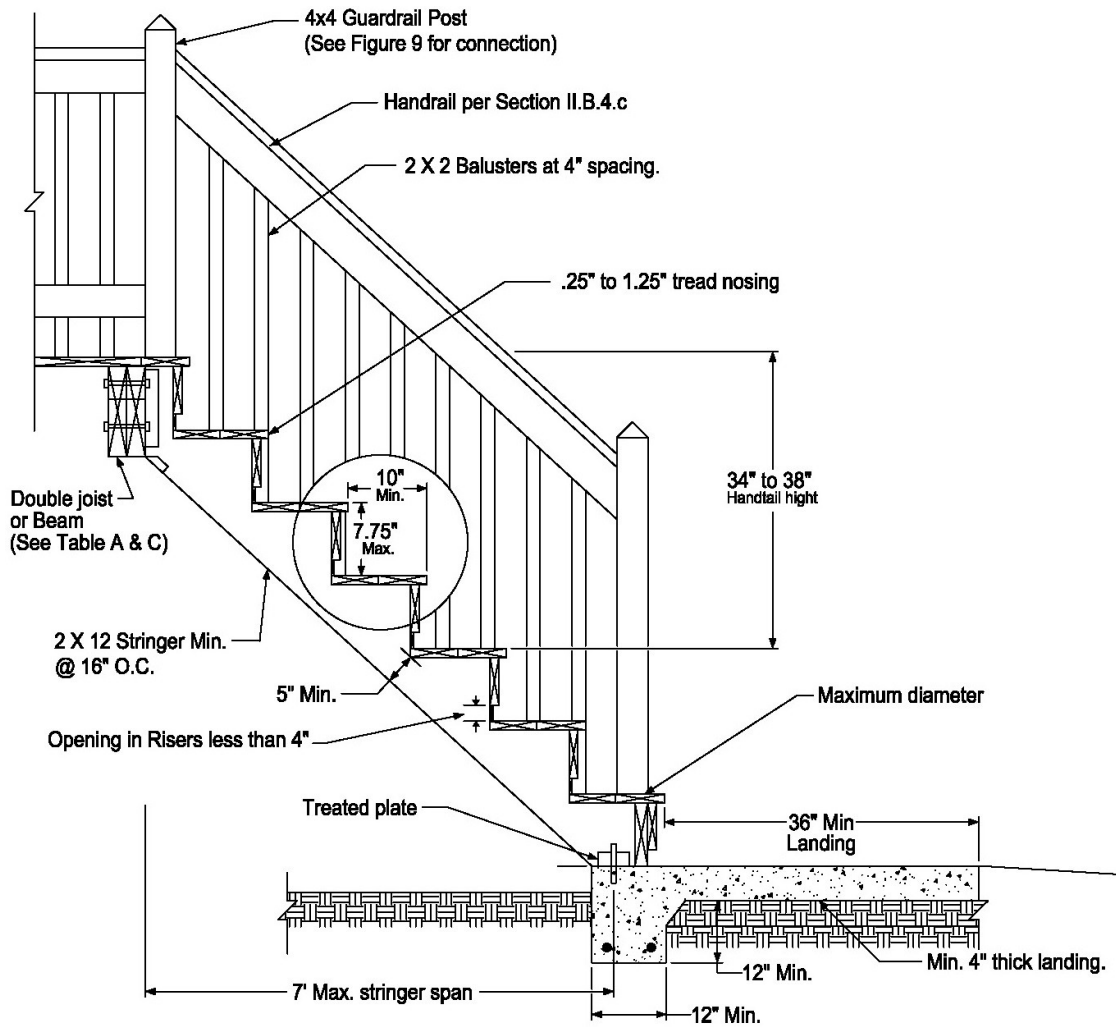

WOOD DECKS IN AREAS WITHIN VERY HIGH FIRE HAZARD SEVERITY ZONES OR CITY OF SAN DIEGO BRUSH MANAGEMENT ZONES MAY BE SUBJECT TO ADDITIONAL REQUIREMENTS

**FIGURE 8 - TYPICAL LEDGER DETAIL (FOR ADDITIONAL LATERAL CONNECTION, SEE FIGURE 11)**

**Case 1 - Ledger to Rim Joist Connection (Attached Deck)**

For additional lateral connection see figure 11

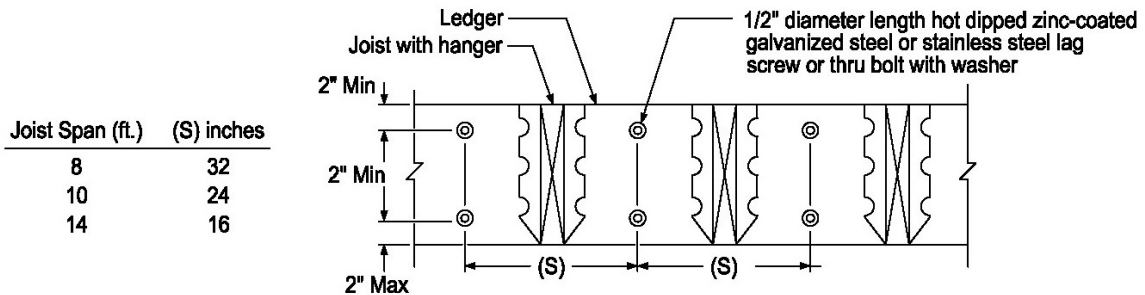
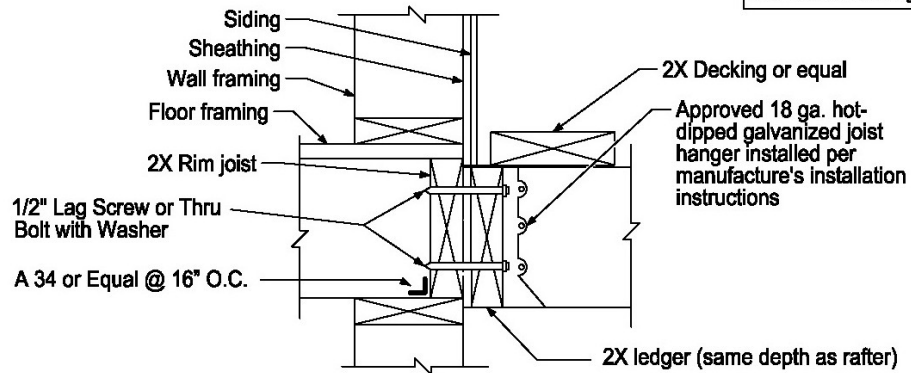

**Case 2 - Rim Joist / Blocking at Stem Wall (Detached Deck)**

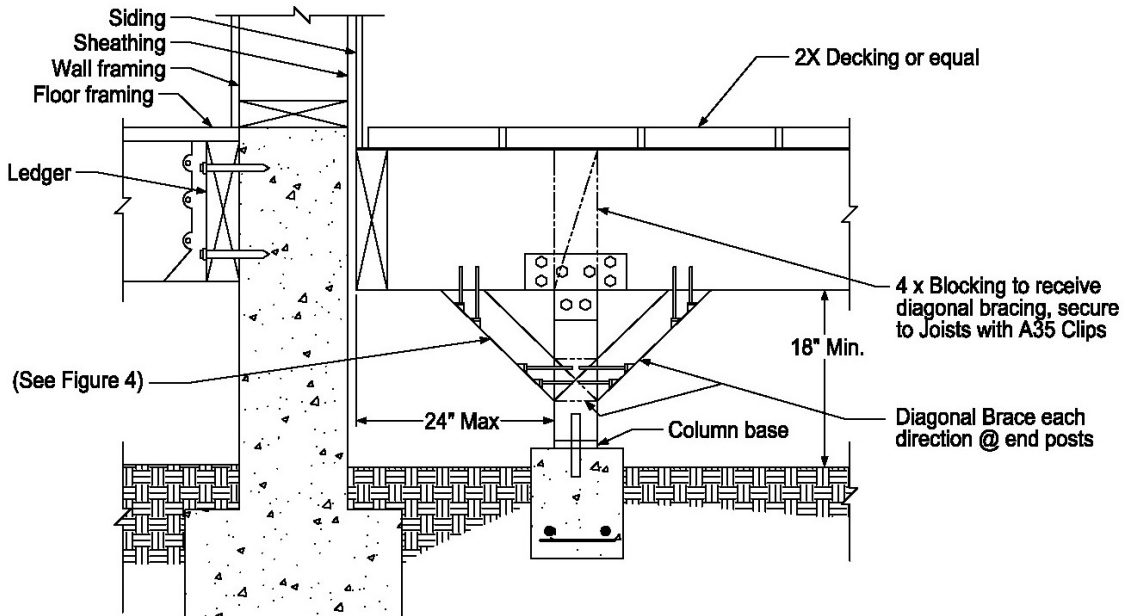

WOOD DECKS IN AREAS WITHIN VERY HIGH FIRE HAZARD SEVERITY ZONES OR CITY OF SAN DIEGO BRUSH MANAGEMENT ZONES MAY BE SUBJECT TO ADDITIONAL REQUIREMENTS

**FIGURE 9 - TYPICAL GUARD DETAILS**

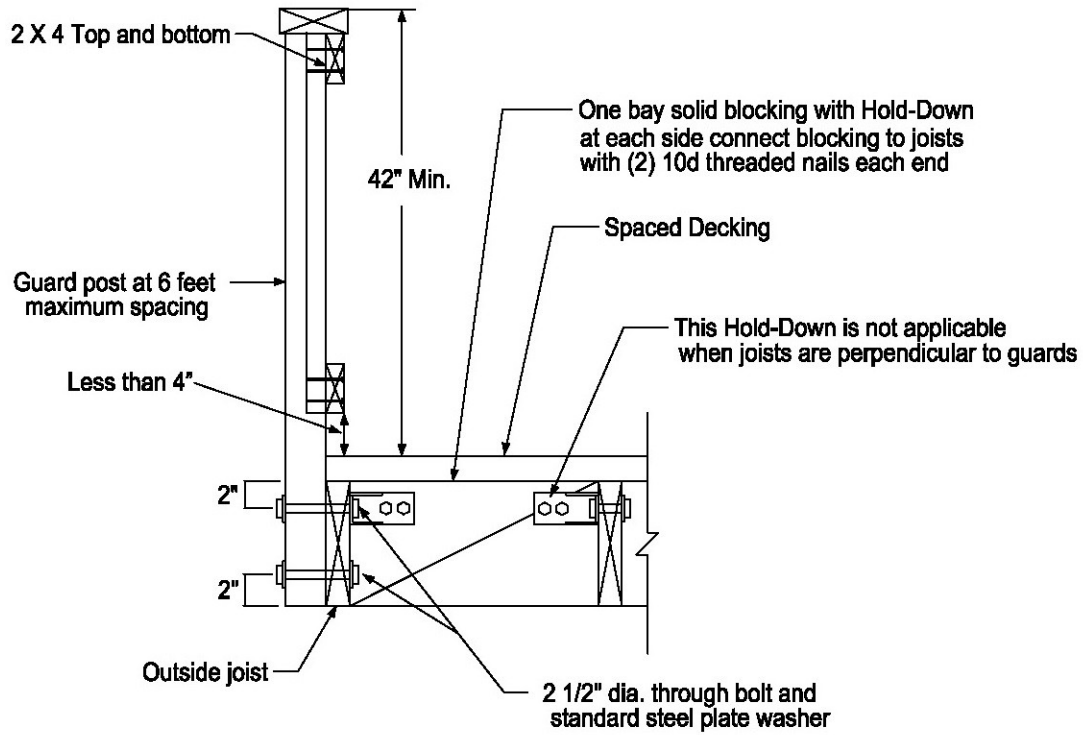

**SECTION**

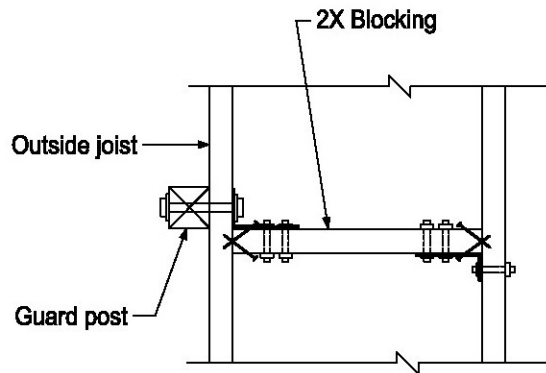

**PLAN VIEW**

**FIGURE 10 - TYPICAL DECK ELEVATION**

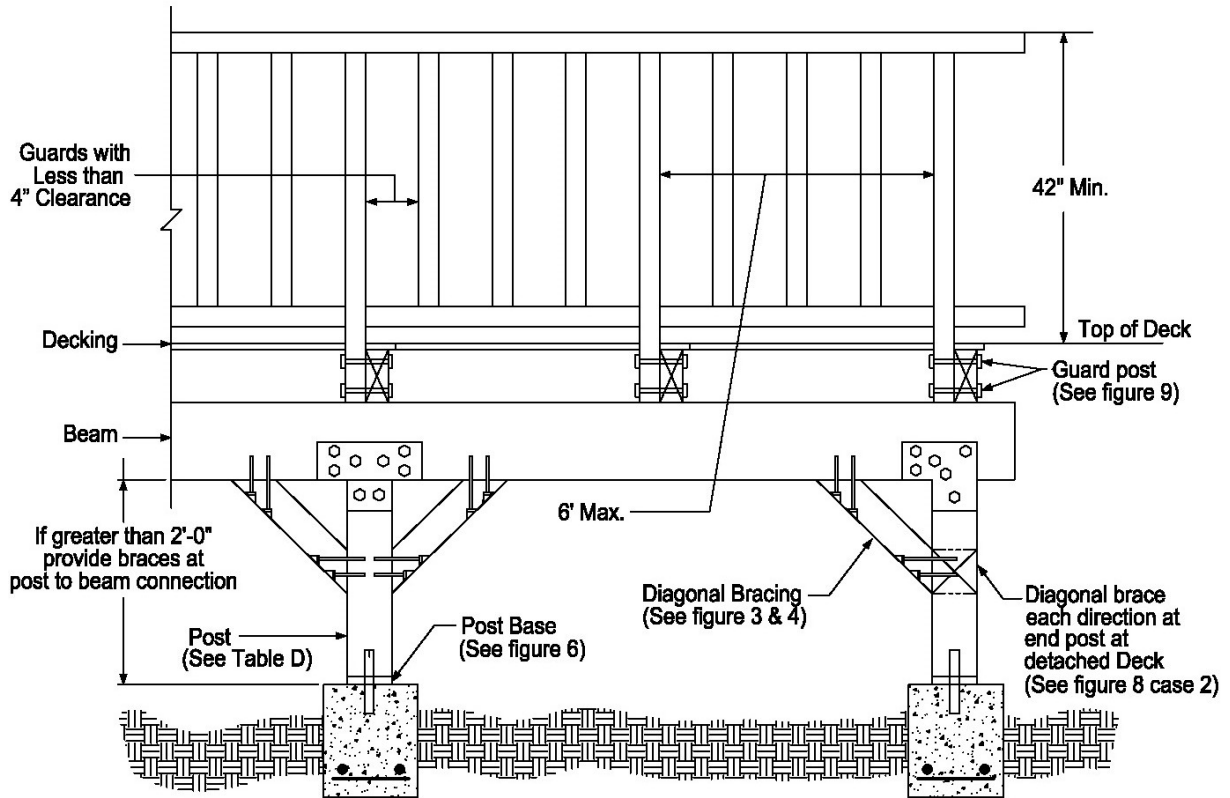

**WOOD DECKS IN AREAS WITHIN VERY HIGH FIRE HAZARD SEVERITY ZONES OR CITY OF SAN DIEGO BRUSH MANAGEMENT ZONES MAY BE SUBJECT TO ADDITIONAL REQUIREMENTS**

**FIGURE 11 - DECK ATTACHMENT FOR LATERAL LOADS**

Two locations for Hold-Downs is required. Place Hold-Downs maximum 24-inches from edge of deck

